

# MANUAL DE SOLUÇÕES

## ENGENHARIA DE CONTROLE MODERNO

4<sup>a</sup> EDIÇÃO

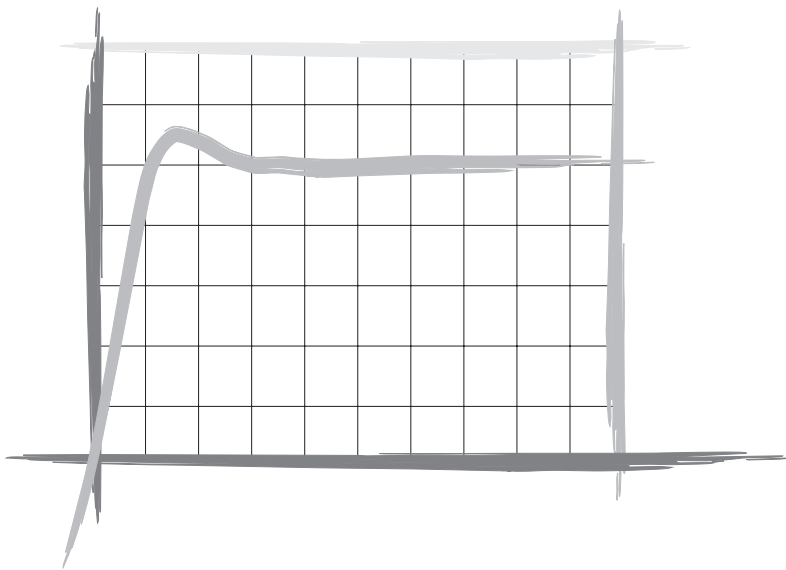

**KATSUHIKO OGATA**

PEARSON  
Prentice  
Hall

Editor: Tom Robbins  
Editora Associada: Alice Dworkin  
Editora Assistente: Jessica Romeo  
Editor Executivo: Vince O'Brien  
Editor Responsável: David A. George  
Produtora Gráfica: Barbara A. Till  
Capa/Design: Paul Gourhan  
Gerente de Produção: Ilene Kahn



© 2002, 1997, 1990, 1970 by Prentice Hall  
Prentice-Hall, Inc.  
Upper Saddle River, NJ 07458

Todos os direitos reservados. Nenhuma parte desta publicação poderá ser reproduzida ou transmitida por qualquer meio, sem prévia autorização, por escrito, da editora.

A produção desta obra envolveu total dedicação e esforço de seu autor e de seu editor. Isso inclui o desenvolvimento, a pesquisa e o teste da teoria e dos programas para determinar sua eficácia. O autor e o editor não garantem, de forma implícita ou explícita, os programas e a documentação apresentados neste livro e não se responsabilizam por quaisquer eventos acidentais ou por quaisquer conseqüências que envolvam ou que sejam oriundos da utilização destes.

Impresso nos Estados Unidos.

10 9 8 7 6 5 4 3 2 1

**ISBN 0-13-060908-0**

Pearson Education Ltd., *London*  
Pearson Education Australia Pty. Ltd., *Sydney*  
Pearson Education Singapore, Pte. Ltd.  
Pearson Education North Asia Ltd., *Hong Kong*  
Pearson Education Canada, Inc., *Toronto*  
Pearson Educación de Mexico, S.A. de C.V.  
Pearson Education Japan, *Tokyo*  
Pearson Education Malaysia. Pte. Ltd.  
Pearson Education, *Upper Saddle River, New Jersey*

# Sumário

Prefácio		iv
2	Transformada de Laplace	1
3	Modelagem Matemática de Sistemas Dinâmicos	11
4	Modelagem Matemática de Sistemas Flúídicos e Sistemas Térmicos	36
5	Análise de Resposta Transitória e de Regime Estacionário	48
6	Análise do Lugar das Raízes	79
7	Projeto de Sistemas de Controle pelo Método do Lugar das Raízes	100
8	Análise de Resposta em Freqüência	137
9	Projeto de Sistemas de Controle pela Resposta em Freqüência	165
10	Controle PID e Sistemas de Controle com Dois Graus de Liberdade	194
11	Análise de Sistemas de Controle no Espaço de Estados	224
12	Projeto de Sistemas de Controle no Espaço de Estados	241

# Prefácio

Este manual apresenta a solução de todos os problemas B sem respostas. Em alguns deles, a solução apresenta informações adicionais ao resultado exigido pelo problema, que visam auxiliar o leitor.

O livro pode ser utilizado de várias maneiras, dependendo dos objetivos e da carga horária do curso a ser ministrado. Alguns exemplos:

**Curso abreviado:**

4 horas-aula/semana, além de  
2 horas de revisão/semana

Total: 40 horas-aula, além de  
20 horas de revisão

Capítulo 1  
Capítulo 2\*  
Capítulo 3  
Capítulo 4\*\*  
Capítulo 5  
Capítulo 6  
Capítulo 7  
Capítulo 8  
Capítulo 9  
Capítulo 10

**Curso completo:**

4 horas-aula/semana, além de  
2 horas de revisão/semana

Total: 56 horas-aula, além de  
28 horas de revisão

Capítulo 1  
Capítulo 2\*  
Capítulo 3  
Capítulo 4  
Capítulo 5  
Capítulo 6  
Capítulo 7  
Capítulo 8  
Capítulo 9  
Capítulo 10  
Capítulo 11  
Capítulo 12

\* Este capítulo poderá ser deixado de lado caso os alunos tenham conhecimento prévio dos conceitos de transformada de Laplace.

\*\* Este capítulo poderá ser deixado de lado caso haja pouco tempo disponível.

O professor pode deixar de lado determinados itens dependendo do objetivo do curso.

*Katsuhiko Ogata*

## CHAPTER 2

B-2-1.

$$(a) \quad F_1(s) = \frac{s+0.4}{(s+0.4)^2 + 12^2} = \frac{s+0.4}{s^2 + 0.8s + 144.16}$$

$$(b) \quad f_2(t) = \sin\left(4t + \frac{\pi}{3}\right) = 0.5 \sin 4t + 0.866 \cos 4t$$

$$F_2(s) = \frac{0.5 \times 4}{s^2 + 4^2} + \frac{0.866s}{s^2 + 4^2} = \frac{2 + 0.866s}{s^2 + 16}$$

---

B-2-2.

$$(a) \quad f_1(t) = 3 \sin(5t + 45^\circ) = 2.121 \sin 5t + 2.121 \cos 5t$$

$$F_1(s) = \frac{2.121 \times 5}{s^2 + 5^2} + \frac{2.121s}{s^2 + 5^2} = \frac{10.607 + 2.121s}{s^2 + 25}$$

$$(b) \quad f_2(t) = 0.03 - 0.03 \cos 2t$$

$$F_2(s) = \frac{0.03}{s} - \frac{0.03s}{s^2 + 4} = \frac{0.03s^2 + 0.12 - 0.03s^2}{s(s^2 + 4)}$$
$$= \frac{0.12}{s(s^2 + 4)}$$

---

B-2-3.

$$\mathcal{L}[t^2] = \frac{2}{s^3}$$

$$F(s) = \mathcal{L}[t^2 e^{-at}] = \frac{2}{(s+a)^3}$$

---

B-2-4.

$$(a) \quad f(t) = \sin \omega t \cdot \cos \omega t = \frac{1}{2} \sin 2\omega t$$

Hence

$$\mathcal{L}[\sin \omega t \cdot \cos \omega t] = \mathcal{L}\left[\frac{1}{2} \sin 2\omega t\right] = \frac{\omega}{s^2 + 4\omega^2}$$

(b) Define

$$g(t) = e^{-t} \sin 5t$$

Then

$$\mathcal{L}[g(t)] = \mathcal{L}[e^{-t} \sin 5t] = \frac{5}{(s+1)^2 + 25} = G(s)$$

Using the complex-differentiation theorem, we have

$$\mathcal{L}[t g(t)] = -\frac{dG(s)}{ds}$$

Hence

$$\begin{aligned} \mathcal{L}[t e^{-t} \sin 5t] &= \mathcal{L}[t g(t)] = -\frac{d}{ds} [G(s)] \\ &= -\frac{d}{ds} \left[ \frac{5}{(s+1)^2 + 25} \right] = \frac{-10(s+1)}{[(s+1)^2 + 25]^2} \end{aligned}$$

---

B-2-5.

$$f(t) = \cos 2\omega t \cdot \cos 3\omega t = \frac{1}{2} (\cos 5\omega t + \cos \omega t)$$

$$\begin{aligned} F(s) &= \frac{1}{2} \left( \frac{s}{s^2 + 25\omega^2} + \frac{s}{s^2 + \omega^2} \right) \\ &= \frac{(s^2 + 13\omega^2)s}{(s^2 + 25\omega^2)(s^2 + \omega^2)} \end{aligned}$$

---

B-2-6.

$$f(t) = (t-a) \mathcal{1}(t-a)$$

$$F(s) = \frac{e^{-as}}{s^2}$$

---

B-2-7.

$$f(t) = t \mathcal{1}(t) - (t-T) \mathcal{1}(t-T)$$

$$F(s) = \frac{1}{s^2} - \frac{e^{-Ts}}{s^2} = \frac{1 - e^{-Ts}}{s^2}$$

---

B-2-8.

$$f(t) = \frac{24}{a^3} t - \frac{24}{a^2} \mathcal{1}(t - \frac{a}{2}) - \frac{24}{a^3} (t-a) \mathcal{1}(t-a)$$

$$F(s) = \frac{24}{a^3} \left( \frac{1}{s^2} - \frac{a e^{-\frac{1}{2}s}}{s} - \frac{e^{-as}}{s^2} \right)$$

$$\begin{aligned}
\lim_{a \rightarrow 0} F(s) &= \frac{24}{s^2} \lim_{a \rightarrow 0} \frac{1 - ase^{-\frac{a}{2}s} - e^{-as}}{a^3} \\
&= \frac{24}{s^2} \lim_{a \rightarrow 0} \frac{\frac{d}{da} (1 - ase^{-\frac{a}{2}s} - e^{-as})}{\frac{d}{da} (a^3)} \\
&= \frac{24}{s^2} \lim_{a \rightarrow 0} \frac{-se^{-\frac{a}{2}s} + a \frac{s^2}{2} e^{-\frac{a}{2}s} + se^{-as}}{3a^2} \\
&= \frac{8}{s^2} \lim_{a \rightarrow 0} \frac{\frac{d}{da} (-se^{-\frac{a}{2}s} + a \frac{s^2}{2} e^{-\frac{a}{2}s} + se^{-as})}{\frac{d}{da} (a^2)} \\
&= \frac{8}{s^2} \lim_{a \rightarrow 0} \frac{\frac{s^2}{2} e^{-\frac{a}{2}s} + \frac{s^2}{2} e^{-\frac{a}{2}s} - \frac{as^2}{4} e^{-\frac{a}{2}s} - se^{-as}}{2a} \\
&= \frac{8}{s^2} \lim_{a \rightarrow 0} \frac{\frac{d}{da} (s^2 e^{-\frac{a}{2}s} - \frac{as^2}{4} e^{-\frac{a}{2}s} - se^{-as})}{\frac{d}{da} (2a)} \\
&= 4 \left( -\frac{s}{2} - \frac{s}{4} + s \right) \\
&= 5
\end{aligned}$$

---

B-2-9.

$$\lim_{t \rightarrow \infty} f(t) = \lim_{s \rightarrow 0} sF(s) = \lim_{s \rightarrow 0} \frac{10s}{s(s+1)} = 10$$

To verify this result, note that

$$\mathcal{L}^{-1} \left[ \frac{10}{s(s+1)} \right] = (10 - 10e^{-t}) 1(t)$$

$$\lim_{t \rightarrow \infty} (10 - 10e^{-t}) 1(t) = 10$$

---

B-2-10.

$$f(0^+) = \lim_{s \rightarrow \infty} sF(s) = \lim_{s \rightarrow \infty} \frac{s}{(s+2)^2} = 0$$

$$\mathcal{L}[\dot{f}(t)] = sF(s) - f(0^+) = sF(s)$$

Hence

$$\dot{f}(0+) = \lim_{s \rightarrow \infty} s^2 F(s) = \lim_{s \rightarrow \infty} \frac{s^2}{(s+2)^2} = 1$$

---

B-2-11.

$$\begin{aligned} F(s) &= \frac{s+1}{s(s^2+s+1)} = \frac{1}{s} - \frac{s+0.5-0.5}{(s+0.5)^2+0.75} \\ &= \frac{1}{s} - \frac{s+0.5}{(s+0.5)^2+0.866^2} + \frac{0.5}{0.866} \frac{0.866}{(s+0.5)^2+0.866^2} \end{aligned}$$

$$f(t) = 1 - e^{-0.5t} \cos 0.866t + \frac{1}{1.732} e^{-0.5t} \sin 0.866t$$

---

B-2-12.

$$F(s) = \frac{se^{-s}}{s+1}$$

Note that for a translated function  $g(t-\alpha)1(t-\alpha)$ , we have

$$\mathcal{L}[g(t-\alpha)1(t-\alpha)] = e^{-\alpha s} G(s) \quad (\alpha \geq 0)$$

Define

$$G(s) = \frac{5}{s+1}$$

Then

$$g(t) = 5e^{-t}$$

So we have

$$\mathcal{L}[5e^{-(t-1)}1(t-1)] = e^{-s} \frac{5}{s+1}$$

or

$$f(t) = \mathcal{L}^{-1}[F(s)] = 5e^{-(t-1)}1(t-1)$$

---

B-2-13.

(a) 
$$F_1(s) = \frac{6s+3}{s^2} = \frac{6}{s} + \frac{3}{s^2}$$

$$f_1(t) = 6 + 3t$$

(b)

$$F_2(s) = \frac{5s+2}{(s+1)(s+2)^2} = -\frac{3}{s+1} + \frac{8}{(s+2)^2} + \frac{3}{s+2}$$

$$f_2(t) = -3e^{-t} + 8te^{-2t} + 3e^{-2t}$$

---

**B-2-14.**

$$(a) \quad F(s) = \frac{1}{s^2(s^2 + \omega^2)} = \frac{1}{\omega^2} \left( \frac{1}{s^2} - \frac{1}{s^2 + \omega^2} \right)$$

$$f(t) = \frac{1}{\omega^2} \left( t - \frac{1}{\omega} \sin \omega t \right)$$

$$(b) \quad F_2(s) = \frac{\omega_n^2}{s(s^2 + 2\zeta\omega_n s + \omega_n^2)} \quad (0 < \zeta < 1)$$

$$= \frac{1}{s} - \frac{s + 2\zeta\omega_n}{s^2 + 2\zeta\omega_n s + \omega_n^2}$$

$$= \frac{1}{s} \left( - \frac{s + \zeta\omega_n}{(s + \zeta\omega_n)^2 + \omega_n^2 - \zeta^2\omega_n^2} - \frac{\zeta\omega_n}{(s + \zeta\omega_n)^2 + \omega_n^2 - \zeta^2\omega_n^2} \right)$$

Hence

$$f_2(t) = 1 - e^{-\zeta\omega_n t} \cos \omega_n \sqrt{1 - \zeta^2} t - \frac{\zeta}{\sqrt{1 - \zeta^2}} e^{-\zeta\omega_n t} \sin \omega_n \sqrt{1 - \zeta^2} t$$

$$= 1 - e^{-\zeta\omega_n t} \left( \cos \omega_n \sqrt{1 - \zeta^2} t + \frac{\zeta}{\sqrt{1 - \zeta^2}} \sin \omega_n \sqrt{1 - \zeta^2} t \right)$$

 $f_2(t)$  can also be written as

$$f_2(t) = 1 - \frac{1}{\sqrt{1 - \zeta^2}} e^{-\zeta\omega_n t} \sin(\omega_n \sqrt{1 - \zeta^2} t + \phi)$$

where

$$\phi = \tan^{-1} \frac{\sqrt{1 - \zeta^2}}{\zeta}$$

**B-2-15.**

$$F(s) = \frac{10(s+2)(s+4)}{(s+1)(s+3)(s+5)^2}$$

A MATLAB program to obtain the partial-fraction expansion of  $F(s)$  is given below.

```

num = conv([10 20],[1 4]);
den = conv([1 4 3],[1 10 25]);
[r,p,k] = residue(num,den)

r =

-2.1875
 3.7500
 1.2500
 0.9375

```

```

p =
-5.0000
-5.0000
-3.0000
-1.0000

k =

[]

```

From the MATLAB output, the partial-fraction expansion of  $F(s)$  can be given as follows:

$$F(s) = \frac{-2.1875}{s+5} + \frac{3.75}{(s+5)^2} + \frac{1.25}{s+3} + \frac{0.9375}{s+1}$$

The inverse Laplace transform of  $F(s)$  is

$$f(t) = -2.1875 e^{-5t} + 3.75 t e^{-5t} + 1.25 e^{-3t} + 0.9375 e^{-t}$$

**B-2-16.**

$$F(s) = \frac{s^4 + 5s^3 + 6s^2 + 9s + 30}{s^4 + 6s^3 + 21s^2 + 46s + 30}$$

A MATLAB program to obtain the partial-fraction expansion of  $F(s)$  is given below.

```

num = [1 5 6 9 30];
den = [1 6 21 46 30];
[r,p,k] = residue(num,den)

r =

-1.0812+1.7051i
-1.0812-1.7051i
-0.1154
1.2778

p =

-1.0000+3.0000i
-1.0000-3.0000i
-3.0000
-1.0000

k =

1

```

From this MATLAB output, the partial-fraction expansion of  $F(s)$  can be given as follows:

$$\begin{aligned}
 F(s) &= \frac{-1.0812 + j1.7051}{s+1-j3} + \frac{-1.0812 - j1.7051}{s+1+j3} - \frac{0.1154}{s+3} + \frac{1.2778}{s+1} + 1 \\
 &= 1 + \frac{-2.1624(s+1) - 10.2306}{(s+1-j3)(s+1+j3)} - \frac{0.1154}{s+3} + \frac{1.2778}{s+1} \\
 &= 1 - \frac{2.1624(s+1)}{(s+1)^2 + 3^2} - \frac{3.4102 \times 3}{(s+1)^2 + 3^2} - \frac{0.1154}{s+3} - \frac{1.2778}{s+1}
 \end{aligned}$$

The inverse Laplace transform of  $F(s)$  becomes as follows:

$$f(t) = \delta(t) - 2.1624e^{-t} \cos 3t - 3.4102 e^{-t} \sin 3t - 0.1154e^{-3t} + 1.2778e^{-t}$$

**B-2-17.**

Zeros at  $s = -1, s = -2$ :

$z = [-1; -2]$

Poles at  $s = 0, s = -4, s = -6$ :

$p = [0; -4; -6]$

gain  $K = 5$ :

$K = 4$

A MATLAB program to obtain  $B(s)/A(s)$  is given below.

```

z = [-1;-2];
p = [0;-4;-6];
K = 4;
[num,den] = zp2tf(z,p,K);
printsys(num,den,'s')

num/den =

      4 s^2 + 12 s + 8
      -----
      s^3 + 10 s^2 + 24 s
    
```

From the MATLAB output, we obtain

$$\frac{B(s)}{A(s)} = \frac{4s^2 + 12s + 8}{s^3 + 10s^2 + 24s}$$

**B-2-18.**

$$2\ddot{x} + 7\dot{x} + 3x = 0, \quad x(0) = 3, \quad \dot{x}(0) = 0$$

$$2[s^2 X(s) - sx(0) - \dot{x}(0)] + 7[sX(s) - x(0)] + 3X(s) = 0$$

$$(2s^2 + 7s + 3) X(s) = 6s + 21$$

$$X(s) = \frac{6s+21}{2s^2+7s+3} = \frac{3s+10.5}{(s+0.5)(s+3)}$$

$$= \frac{3.6}{s+0.5} - \frac{0.6}{s+3}$$

$$x(t) = 3.6 e^{-0.5t} - 0.6 e^{-3t}$$

---

B-2-19.

$$\dot{x} + 2x = \delta(t), \quad x(0^-) = 0$$

$$sX(s) - x(0^-) + 2X(s) = 1$$

$$(s+2)X(s) = 1$$

$$X(s) = \frac{1}{s+2}$$

$$x(t) = e^{-2t} 1(t)$$

---

B-2-20.

$$x(t) = a e^{-\zeta \omega_n t} \left( \cos \omega_n \sqrt{1-\zeta^2} t + \frac{b + a \zeta \omega_n}{a \omega_n \sqrt{1-\zeta^2}} \sin \omega_n \sqrt{1-\zeta^2} t \right)$$

( $0 \leq \zeta < 1$ )

$$x(t) = a e^{-\omega_n t} + (b + \omega_n a) e^{-\omega_n t} t \quad (\zeta = 1)$$

$$x(t) = \left\{ -\frac{a}{2} \left( \frac{-\sqrt{\zeta^2-1} + \zeta}{\sqrt{\zeta^2-1}} \right) - \frac{b}{2\omega_n \sqrt{\zeta^2-1}} \right\} e^{-(\zeta + \sqrt{\zeta^2-1})\omega_n t}$$

$$+ \left\{ \frac{a}{2} \left( \frac{\sqrt{\zeta^2-1} + \zeta}{\sqrt{\zeta^2-1}} \right) + \frac{b}{2\omega_n \sqrt{\zeta^2-1}} \right\} e^{-(\zeta - \sqrt{\zeta^2-1})\omega_n t}$$

( $\zeta > 1$ )

---

B-2-21. Laplace transforming both sides of the differential equation, we get

$$sX(s) - x(0) + aX(s) = A \frac{\omega}{s^2 + \omega^2}$$

or

$$(s+a)X(s) = \frac{Aw}{s^2 + \omega^2} + b$$

Solving for  $X(s)$ , we obtain

$$\begin{aligned} X(s) &= \frac{Aw}{(s+a)(s^2 + \omega^2)} + \frac{b}{s+a} \\ &= \frac{Aw}{a^2 + \omega^2} \left( \frac{1}{s+a} - \frac{s-a}{s^2 + \omega^2} \right) + \frac{b}{s+a} \\ &= \left( b + \frac{Aw}{a^2 + \omega^2} \right) \frac{1}{s+a} + \frac{Aa}{a^2 + \omega^2} \frac{\omega}{s^2 + \omega^2} \\ &\quad - \frac{Aw}{a^2 + \omega^2} \frac{s}{s^2 + \omega^2} \end{aligned}$$

Inverse Laplace transform of  $X(s)$  gives

$$\begin{aligned} x(t) &= \mathcal{L}^{-1}[X(s)] \\ &= \left( b + \frac{Aw}{a^2 + \omega^2} \right) e^{-at} + \frac{Aa}{a^2 + \omega^2} \sin \omega t - \frac{Aw}{a^2 + \omega^2} \cos \omega t \\ &\quad (t \geq 0) \end{aligned}$$

B-2-22.

$$\ddot{x} + 3\dot{x} + 6x = 0, \quad x(0) = 0, \quad \dot{x}(0) = 3$$

The Laplace transform of this differential equation is

$$s^2 X(s) - s x(0) - \dot{x}(0) + 3[sX(s) - x(0)] + 6X(s) = 0$$

By substituting the given initial condition to the last equation, we obtain

$$s^2 X(s) - 3 + 3sX(s) + 6X(s) = 0$$

from which we get

$$X(s) = \frac{3}{s^2 + 3s + 6} = \frac{3}{(s+1.5)^2 + \left(\frac{\sqrt{15}}{2}\right)^2} = \frac{6}{\sqrt{15}} \frac{\frac{\sqrt{15}}{2}}{(s+1.5)^2 + \left(\frac{\sqrt{15}}{2}\right)^2}$$

Hence

$$x(t) = \frac{6}{\sqrt{15}} e^{-1.5t} \sin \frac{\sqrt{15}}{2} t$$

B-2-23.

$$\ddot{x} + 2\dot{x} + 10x = e^{-t}, \quad x(0) = 0, \quad \dot{x}(0) = 0$$

The forcing function  $e^{-t}$  is given at  $t = 0$ , when the system is at rest. Taking the Laplace transform of the differential equation, we obtain

$$s^2 X(s) - s x(0) - \dot{x}(0) + 2[sX(s) - x(0)] + 10 X(s) = \frac{1}{s+1}$$

By substituting the given initial condition into this last equation, we get

$$s^2 X(s) + 2s X(s) + 10 X(s) = \frac{1}{s+1}$$

or

$$X(s) = \frac{1}{s^2 + 2s + 10} \frac{1}{s+1} = \frac{1}{9} \frac{1}{s+1} - \frac{1}{9} \frac{s+1}{(s+1)^2 + 3^2}$$

The inverse Laplace transform of  $X(s)$  gives

$$x(t) = \frac{1}{9} e^{-t} - \frac{1}{9} e^{-t} \cos 3t \quad (t \geq 0)$$

---

# CHAPTER 3

**B-3-1.**

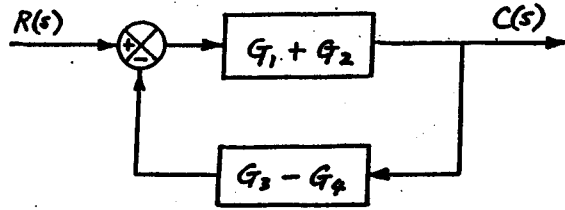

$$\frac{C(s)}{R(s)} = \frac{G_1 + G_2}{1 + (G_1 + G_2)(G_3 - G_4)}$$

**B-3-2.**

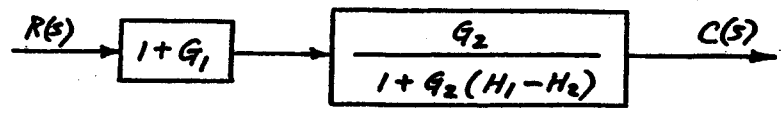
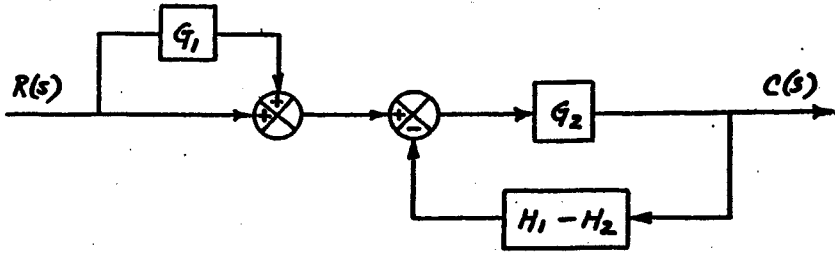

$$\frac{C(s)}{R(s)} = \frac{(1 + G_1)G_2}{1 + G_2(H_1 - H_2)}$$

**B-3-3.**

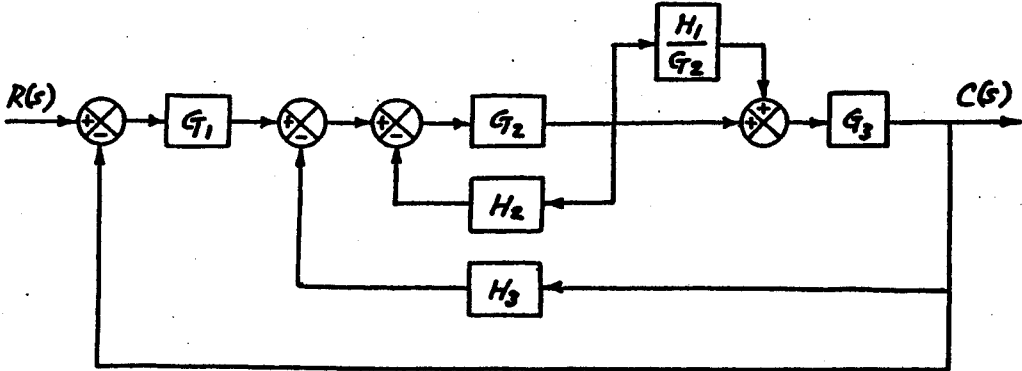

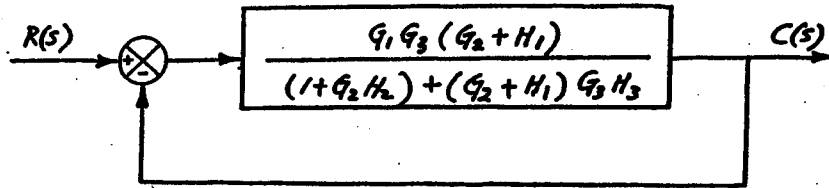
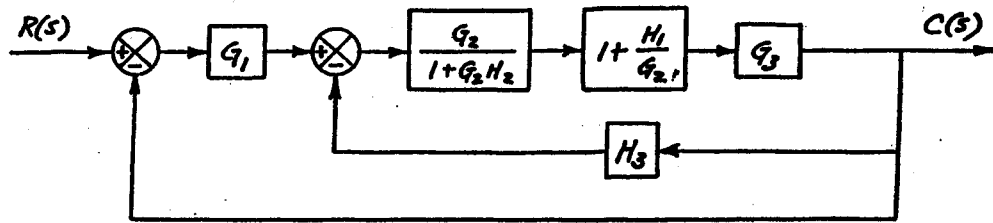

$$\frac{C(s)}{R(s)} = \frac{G_1 G_2 G_3 + G_1 G_3 H_1}{1 + G_2 H_2 + G_2 G_3 H_3 + G_3 H_1 H_3 + G_1 G_2 G_3 + G_1 G_3 H_1}$$

**B-3-4.** In the following diagrams, (a) denotes the unit-step response and (b) corresponds to the unit-ramp response.

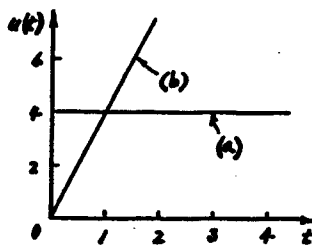

$$\frac{U(s)}{E(s)} = K_p = 4$$

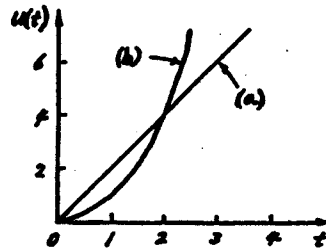

$$\frac{U(s)}{E(s)} = \frac{K_i}{s} = \frac{2}{s}$$

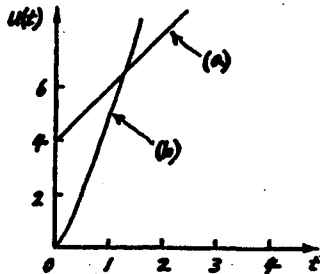

$$\frac{U(s)}{E(s)} = K_p \left(1 + \frac{1}{T_i s}\right) = 4 \left(1 + \frac{1}{2s}\right)$$

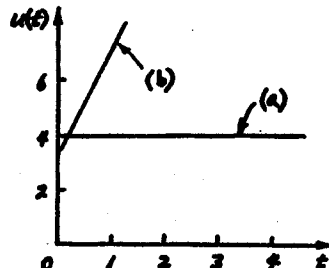

$$\frac{U(s)}{E(s)} = K_p (1 + T_d s) = 4 (1 + 0.8s)$$

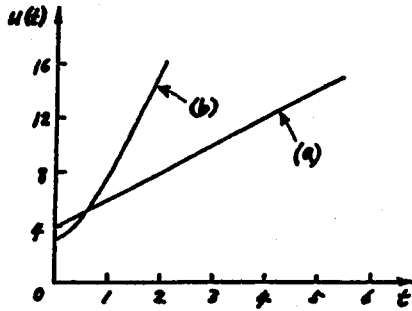

$$\frac{U(s)}{E(s)} = K_p \left( 1 + \frac{1}{T_i s} + T_d s \right) = 4 \left( 1 + \frac{1}{2s} + 0.2s \right)$$

**B-3-5.** When  $D(s)$  is zero, the closed-loop transfer function  $C_R(s)/R(s)$  is

$$\frac{C_R(s)}{R(s)} = \frac{G_c(s) G_p(s)}{1 + G_c(s) G_p(s)}$$

When  $R(s) = 0$ , the closed-loop transfer function  $C_D(s)/D(s)$  is

$$\frac{C_D(s)}{D(s)} = \frac{1}{1 + G_c(s) G_p(s)}$$

When both the reference input and disturbance input are present, the output  $C(s)$  is the sum of  $C_R(s)$  and  $C_D(s)$ . Hence

$$C(s) = C_R(s) + C_D(s) = \frac{1}{1 + G_c(s) G_p(s)} \left[ G_c(s) G_p(s) R(s) + D(s) \right]$$

**B-3-6.** When only the reference input  $R(s)$  is present, the output  $C_R(s)$  is given

by

$$\frac{C_R(s)}{R(s)} = \frac{G_1(s) G_2(s)}{1 + G_1(s) G_2(s)}$$

For the reference input  $R(s)$ , the desired output is  $R(s)$  for the unity-feedback system such as the present system. Thus, the error  $E_R(s)$  is the difference between  $R(s)$  and the actual output  $C_R(s)$ . The error  $E_R(s)$  is given by

$$\begin{aligned} E_R(s) &= R(s) - C_R(s) = R(s) \left[ 1 - \frac{C_R(s)}{R(s)} \right] \\ &= R(s) \left[ 1 - \frac{G_1(s) G_2(s)}{1 + G_1(s) G_2(s)} \right] = \frac{1}{1 + G_1(s) G_2(s)} R(s) \end{aligned}$$

Assuming the system to be stable, the steady-state error  $e_{SSR}(t)$  can be given

by

$$e_{SSR}(t) = \lim_{t \rightarrow \infty} e_R(t) = \lim_{s \rightarrow 0} s E_R(s) = \lim_{s \rightarrow 0} \frac{s R(s)}{1 + G_1(s) G_2(s)}$$

When only the disturbance input  $D(s)$  is present, the output  $C_D(s)$  is given by

$$\frac{C_D(s)}{D(s)} = \frac{G_2(s)}{1 + G_1(s)G_2(s)}$$

Since the desired output to the disturbance input  $D(s)$  is zero, the error  $E_D(s)$  can be given by

$$E_D(s) = 0 - C_D(s) = -C_D(s)$$

Hence

$$E_D(s) = -C_D(s) = -\frac{G_2(s)}{1 + G_1(s)G_2(s)} D(s)$$

For the stable system, the steady-state error  $e_{ssD}(t)$  is given by

$$e_{ssD}(t) = \lim_{t \rightarrow \infty} e_D(t) = \lim_{s \rightarrow 0} s E_D(s) = \lim_{s \rightarrow 0} \frac{-s G_2(s) D(s)}{1 + G_1(s)G_2(s)}$$

The steady-state error when both the reference input  $R(s)$  and disturbance input  $D(s)$  are present is the sum of  $e_{ssR}(t)$  and  $e_{ssD}(t)$  and is given by

$$\begin{aligned} e_{ss}(t) &= e_{ssR}(t) + e_{ssD}(t) \\ &= \lim_{s \rightarrow 0} \left[ \frac{s R(s)}{1 + G_1(s)G_2(s)} - \frac{s G_2(s) D(s)}{1 + G_1(s)G_2(s)} \right] \\ &= \lim_{s \rightarrow 0} \left\{ \frac{s}{1 + G_1(s)G_2(s)} [R(s) - G_2(s) D(s)] \right\} \end{aligned}$$

**B-3-7.** When  $D(s) = 0$ , the block diagram of the system can be simplified as follows:

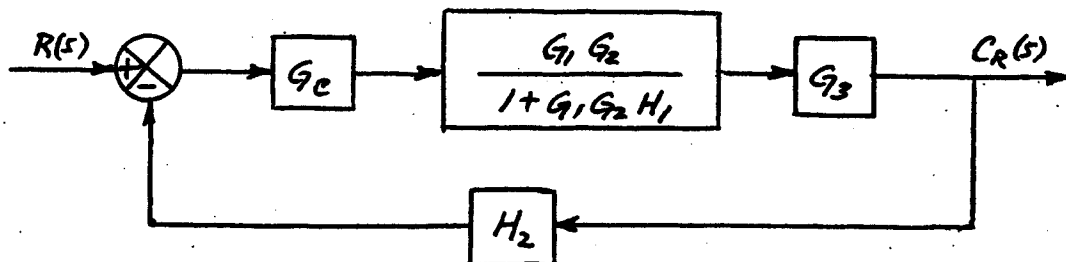

The closed-loop transfer function  $C_R(s)/R(s)$  can be given by

$$\frac{C_R(s)}{R(s)} = \frac{\frac{G_c G_1 G_2 G_3}{1 + G_1 G_2 H_1}}{1 + \frac{G_c G_1 G_2 G_3 H_2}{1 + G_1 G_2 H_1}} = \frac{G_c G_1 G_2 G_3}{1 + G_1 G_2 H_1 + G_c G_1 G_2 G_3 H_2}$$

When  $R(s) = 0$ , the block diagram of the system shown in Figure 3-76 can be modified as follows:

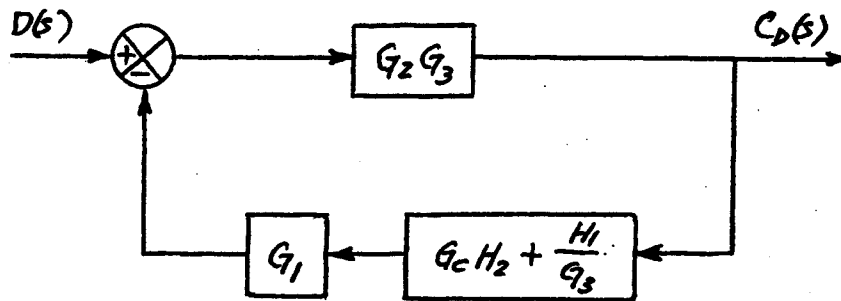
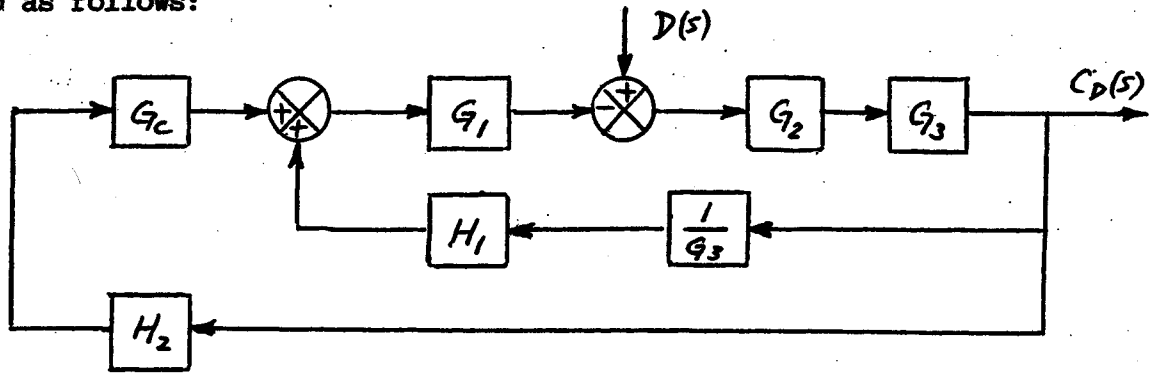

Hence

$$\frac{C_D(s)}{D(s)} = \frac{G_2 G_3}{1 + G_2 G_3 G_1 \left( G_c H_2 + \frac{H_1}{G_3} \right)} = \frac{G_2 G_3}{1 + G_1 G_2 G_3 G_c H_2 + G_1 G_2 H_1}$$

**B-3-8.** There are infinitely many state-space representations for this system. We shall give two of the possible state-space representations.

State-space representation 1: From Figure 3-77, we obtain

$$\frac{Y(s)}{U(s)} = \frac{\frac{s+z}{s+p} \frac{1}{s^2}}{1 + \frac{s+z}{s+p} \frac{1}{s^2}} = \frac{s+z}{s^3 + ps^2 + s + z}$$

which is equivalent to

$$\ddot{y} + p\dot{y} + y + zy = \dot{u} + zu$$

Comparing this equation with the standard equation

$$\ddot{y} + a_1\dot{y} + a_2y = b_0\ddot{u} + b_1\dot{u} + b_2\dot{u} + b_3u$$

we obtain

$$a_1 = p, \quad a_2 = 1, \quad a_3 = z, \quad b_0 = 0, \quad b_1 = 0, \quad b_2 = 1, \quad b_3 = z$$

Define

$$x_1 = y - \beta_0 u$$

$$x_2 = \dot{y} - \beta_0 \dot{u} - \beta_1 u = \dot{x}_1 - \beta_1 u$$

$$x_3 = \ddot{x}_2 - \beta_2 u$$

where

$$\beta_0 = b_0 = 0$$

$$\beta_1 = b_1 - a_1 \beta_0 = 0$$

$$\beta_2 = b_2 - a_1 \beta_1 - a_2 \beta_0 = 1$$

$$\beta_3 = b_3 - a_1 \beta_2 - a_2 \beta_1 - a_3 \beta_0 = z - p$$

Then, state-space equations can be given by

$$\begin{bmatrix} \dot{x}_1 \\ \dot{x}_2 \\ \dot{x}_3 \end{bmatrix} = \begin{bmatrix} 0 & 1 & 0 \\ 0 & 0 & 1 \\ -z & -1 & -p \end{bmatrix} \begin{bmatrix} x_1 \\ x_2 \\ x_3 \end{bmatrix} + \begin{bmatrix} \beta_1 \\ \beta_2 \\ \beta_3 \end{bmatrix} u$$

$$y = [1 \ 0 \ 0] \begin{bmatrix} x_1 \\ x_2 \\ x_3 \end{bmatrix} + \beta_0 u$$

or

$$\begin{bmatrix} \dot{x}_1 \\ \dot{x}_2 \\ \dot{x}_3 \end{bmatrix} = \begin{bmatrix} 0 & 1 & 0 \\ 0 & 0 & 1 \\ -z & -1 & -p \end{bmatrix} \begin{bmatrix} x_1 \\ x_2 \\ x_3 \end{bmatrix} + \begin{bmatrix} 0 \\ 1 \\ z-p \end{bmatrix} u$$

$$y = [1 \ 0 \ 0] \begin{bmatrix} x_1 \\ x_2 \\ x_3 \end{bmatrix}$$

State-space representation 2: Since

$$\frac{s+z}{s+p} = \frac{s+p+z-p}{s+p} = 1 + \frac{z-p}{s+p}$$

we can redraw the block diagram as shown below.

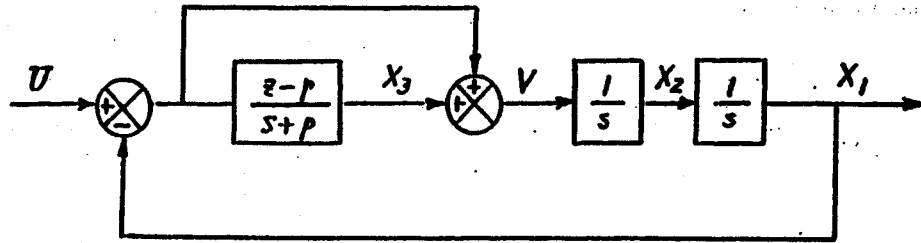

From this block diagram we get the following equations:

$$V = U - X_1 + X_3$$

$$\frac{X_3}{U - X_1 + X_3} = \frac{z-p}{s+p}$$

$$\frac{X_2}{U - X_1 + X_3} = \frac{1}{s}$$

$$\frac{X_1}{X_2} = \frac{1}{s}$$

from which we obtain

$$\dot{x}_3 + px_3 = (z-p)u - (z-p)x_1$$

$$\dot{x}_2 = -x_1 + x_3 + u$$

$$\dot{x}_1 = x_2$$

Rewriting, we have

$$\dot{x}_1 = x_2$$

$$\dot{x}_2 = -x_1 + x_3 + u$$

$$\dot{x}_3 = -(z-p)x_1 - px_3 + (z-p)u$$

$$y = x_1$$

or

$$\begin{bmatrix} \dot{x}_1 \\ \dot{x}_2 \\ \dot{x}_3 \end{bmatrix} = \begin{bmatrix} 0 & 1 & 0 \\ -1 & 0 & 1 \\ p-z & 0 & -p \end{bmatrix} \begin{bmatrix} x_1 \\ x_2 \\ x_3 \end{bmatrix} + \begin{bmatrix} 0 \\ 1 \\ z-p \end{bmatrix} u$$

$$y = \begin{bmatrix} 1 & 0 & 0 \end{bmatrix} \begin{bmatrix} x_1 \\ x_2 \\ x_3 \end{bmatrix}$$

---

B-3-9.

$$\ddot{y} + 3\dot{y} + 2y = u$$

Define

$$x_1 = y$$

$$x_2 = \dot{y}$$

$$x_3 = \ddot{y}$$

Then

$$\dot{x}_3 + 3x_3 + 2x_2 = u$$

$$\dot{x}_2 = x_3$$

$$\dot{x}_1 = x_2$$

or

$$\begin{bmatrix} \dot{x}_1 \\ \dot{x}_2 \\ \dot{x}_3 \end{bmatrix} = \begin{bmatrix} 0 & 1 & 0 \\ 0 & 0 & 1 \\ 0 & -2 & -3 \end{bmatrix} \begin{bmatrix} x_1 \\ x_2 \\ x_3 \end{bmatrix} + \begin{bmatrix} 0 \\ 0 \\ 1 \end{bmatrix} u$$

$$y = \begin{bmatrix} 1 & 0 & 0 \end{bmatrix} \begin{bmatrix} x_1 \\ x_2 \\ x_3 \end{bmatrix}$$

---

B-3-10.

$$A_m = \begin{bmatrix} -4 & -1 \\ 3 & -1 \end{bmatrix}, \quad B_m = \begin{bmatrix} 1 \\ 1 \end{bmatrix}, \quad C_m = \begin{bmatrix} 1 & 0 \end{bmatrix}$$

The transfer function  $G(s)$  of the system is given by

$$G(s) = C_m (sI_m - A_m)^{-1} B_m = \begin{bmatrix} 1 & 0 \end{bmatrix} \begin{bmatrix} s+4 & 1 \\ -3 & s+1 \end{bmatrix}^{-1} \begin{bmatrix} 1 \\ 1 \end{bmatrix}$$

$$\begin{aligned}
&= [1 \ 0] \frac{1}{(s+4)(s+1)+3} \begin{bmatrix} s+1 & -1 \\ 3 & s+4 \end{bmatrix} \begin{bmatrix} 1 \\ 1 \end{bmatrix} \\
&= \frac{1}{s^2+5s+7} [1 \ 0] \begin{bmatrix} s \\ s+7 \end{bmatrix} \\
&= \frac{s}{s^2+5s+7}
\end{aligned}$$

---

**B-3-11.**

$$\underline{A} = \begin{bmatrix} -5 & -1 \\ 3 & -1 \end{bmatrix}, \quad \underline{B}_m = \begin{bmatrix} 2 \\ 5 \end{bmatrix}, \quad \underline{C}_m = [1 \ 2]$$

The transfer function  $G(s)$  of the system is given by

$$\begin{aligned}
G(s) &= \underline{C}_m (s\underline{I} - \underline{A})^{-1} \underline{B}_m = [1 \ 2] \begin{bmatrix} s+5 & 1 \\ -3 & s+1 \end{bmatrix}^{-1} \begin{bmatrix} 2 \\ 5 \end{bmatrix} \\
&= [1 \ 2] \frac{1}{(s+5)(s+1)+3} \begin{bmatrix} s+1 & -1 \\ 3 & s+5 \end{bmatrix} \begin{bmatrix} 2 \\ 5 \end{bmatrix} \\
&= \frac{1}{s^2+6s+8} [1 \ 2] \begin{bmatrix} 2s-3 \\ 5s+31 \end{bmatrix} = \frac{12s+59}{s^2+6s+8}
\end{aligned}$$

A MATLAB solution to this problem is given below.

```

A = [-5 -1; 3 -1];
B = [2; 5];
C = [1 2];
D = 0;
[num,den] = ss2tf(A,B,C,D)

num =

    0   12   59

den =

    1    6    8

```

**B-3-12.**

$$\underline{A} = \begin{bmatrix} 0 & 1 & 0 \\ 0 & 0 & 1 \\ -2 & -4 & -6 \end{bmatrix}, \quad \underline{B}_m = \begin{bmatrix} 0 & 0 \\ 0 & 1 \\ 1 & 0 \end{bmatrix}, \quad \underline{C}_m = \begin{bmatrix} 1 & 0 & 0 \\ 0 & 1 & 0 \end{bmatrix}$$

The transfer matrix of the system can be given by

$$\begin{aligned}
 G(s) &= C_m (sI_m - A_m)^{-1} B_m = \begin{bmatrix} 1 & 0 & 0 \\ 0 & 1 & 0 \end{bmatrix} \begin{bmatrix} s & -1 & 0 \\ 0 & s & -1 \\ 2 & 4 & s+6 \end{bmatrix}^{-1} \begin{bmatrix} 0 & 0 \\ 0 & 1 \\ 1 & 0 \end{bmatrix} \\
 &= \begin{bmatrix} 1 & 0 & 0 \\ 0 & 1 & 0 \end{bmatrix} \frac{1}{s^3 + 6s^2 + 4s + 2} \begin{bmatrix} s^2 + s + 4 & s + 6 & 1 \\ -2 & s^2 + 6s & s \\ -2s & -4s - 2 & s^2 \end{bmatrix} \begin{bmatrix} 0 & 0 \\ 0 & 1 \\ 1 & 0 \end{bmatrix} \\
 &= \frac{1}{s^3 + 6s^2 + 4s + 2} \begin{bmatrix} 1 & s + 6 \\ s & s^2 + 6s \end{bmatrix} \\
 &= \begin{bmatrix} \frac{1}{s^3 + 6s^2 + 4s + 2} & \frac{s + 6}{s^3 + 6s^2 + 4s + 2} \\ \frac{s}{s^3 + 6s^2 + 4s + 2} & \frac{s^2 + 6s}{s^3 + 6s^2 + 4s + 2} \end{bmatrix}
 \end{aligned}$$

A MATLAB solution to this problem is given below.

```

A=[0 1 0;0 0 1;-2 -4 -6];
B=[0 0;0 1;1 0];
C=[1 0 0;0 1 0];
D=[0 0;0 0];
[num,den]=ss2tf(A,B,C,D,1)

num =

    0    0.0000    0.0000    1.0000
    0    0.0000    1.0000    0.0000

den =

    1.0000    6.0000    4.0000    2.0000

[num,den]=ss2tf(A,B,C,D,2)

num =

    0    0.0000    1.0000    6.0000
    0    1.0000    6.0000    0.0000

den =

    1.0000    6.0000    4.0000    2.0000

```

**B-3-13.** Since the same force transmits the shaft, we have

$$f = b_1 (\dot{z} - \dot{x}) = b_2 (\dot{y} - \dot{z}) + b_3 (\dot{y} - \dot{z}) \quad (1)$$

where displacement  $z$  is defined in the figure below.

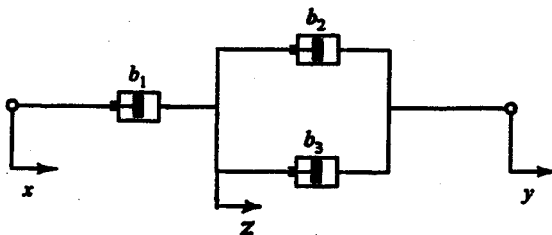

In terms of the equivalent viscous friction coefficient, the force  $f$  is given by

$$f = b_{eq} (\dot{y} - \dot{x}) \quad (2)$$

From Equation (1) we have

$$b_1 \dot{z} + b_2 \dot{z} + b_3 \dot{z} = b_1 \dot{x} + b_2 \dot{y} + b_3 \dot{y}$$

or

$$\dot{z} = \frac{1}{b_1 + b_2 + b_3} [b_1 \dot{x} + (b_2 + b_3) \dot{y}] \quad (3)$$

By substituting Equation (2) into Equation (1), we have

$$\begin{aligned} f &= b_1 (\dot{z} - \dot{x}) = b_1 \left\{ \frac{1}{b_1 + b_2 + b_3} [b_1 \dot{x} + (b_2 + b_3) \dot{y}] - \dot{x} \right\} \\ &= b_1 \frac{b_2 + b_3}{b_1 + b_2 + b_3} (\dot{y} - \dot{x}) \end{aligned} \quad (4)$$

Hence, by comparing Equations (2) and (4), we obtain

$$b_{eq} = b_1 \frac{b_2 + b_3}{b_1 + b_2 + b_3} = \frac{1}{\frac{1}{b_2 + b_3} + \frac{1}{b_1}}$$

**B-3-14.**

(a)

$$m\ddot{x} + kx = u$$

$$\frac{X(s)}{U(s)} = \frac{1}{ms^2 + k}$$

(b) Define the displacement of a point between springs  $k_1$  and  $k_2$  as  $y$ . Then the equations of motion for this system become

$$\begin{aligned} m\ddot{x} + k_2(x - y) &= u \\ k_1 y &= k_2(x - y) \end{aligned}$$

From the second equation, we have

$$k_1 y + k_2 y = k_2 x$$

or

$$y = \frac{k_2}{k_1 + k_2} x$$

Then

$$m\ddot{x} + \frac{k_1 k_2}{k_1 + k_2} x = u$$

or

$$\frac{X(s)}{U(s)} = \frac{1}{ms^2 + \frac{k_1 k_2}{k_1 + k_2}}$$

---

B-3-15.

$$m_1 \ddot{y}_1 + b_1 (\dot{y}_1 - \dot{y}_2) + k_1 y_1 = u_1$$

$$m_2 \ddot{y}_2 + b_1 (\dot{y}_2 - \dot{y}_1) + k_2 y_2 = u_2$$

Define

$$x_1 = y_1$$

$$x_2 = \dot{y}_1$$

$$x_3 = y_2$$

$$x_4 = \dot{y}_2$$

Then

$$m_1 \dot{x}_2 + b_1 (x_2 - x_4) + k_1 x_1 = u_1$$

$$m_2 \dot{x}_4 + b_1 (x_4 - x_2) + k_2 x_3 = u_2$$

Hence

$$\dot{x}_1 = x_2$$

$$\dot{x}_2 = -\frac{1}{m_1} [b_1 (x_2 - x_4) + k_1 x_1] + \frac{1}{m_1} u_1$$

$$\dot{x}_3 = x_4$$

$$\dot{x}_4 = -\frac{1}{m_2} [b_1 (x_4 - x_2) + k_2 x_3] + \frac{1}{m_2} u_2$$

or

$$\begin{bmatrix} \dot{x}_1 \\ \dot{x}_2 \\ \dot{x}_3 \\ \dot{x}_4 \end{bmatrix} = \begin{bmatrix} 0 & 1 & 0 & 0 \\ -\frac{k_1}{m_1} & -\frac{b_1}{m_1} & 0 & \frac{b_1}{m_1} \\ 0 & 0 & 0 & 1 \\ 0 & \frac{b_1}{m_2} & -\frac{k_2}{m_2} & -\frac{b_1}{m_2} \end{bmatrix} \begin{bmatrix} x_1 \\ x_2 \\ x_3 \\ x_4 \end{bmatrix} + \begin{bmatrix} 0 & 0 \\ \frac{1}{m_1} & 0 \\ 0 & 0 \\ 0 & \frac{1}{m_2} \end{bmatrix} \begin{bmatrix} u_1 \\ u_2 \end{bmatrix}$$

$$\begin{bmatrix} y_1 \\ y_2 \end{bmatrix} = \begin{bmatrix} 1 & 0 & 0 & 0 \\ 0 & 0 & 1 & 0 \end{bmatrix} \begin{bmatrix} x_1 \\ x_2 \\ x_3 \\ x_4 \end{bmatrix}$$

B-3-16.

$$J\ddot{\theta} = T$$

where

$$T = -2ka^2\theta - mgl\sin\theta$$

$$J = ml^2$$

For small  $\theta$ ,

$$ml^2\ddot{\theta} = -2ka^2\theta - mgl\theta$$

or

$$\ddot{\theta} + \left( \frac{2ka^2}{ml^2} + \frac{g}{l} \right) \theta = 0$$

B-3-17. Note that

$$x_g = x + l\sin\theta, \quad y_g = l\cos\theta$$

For x direction:

$$M\ddot{x} + m\ddot{x}_g = u$$

or

$$M\ddot{x} + m \frac{d^2}{dt^2} (x + l\sin\theta) = u$$

Since

$$\frac{d^2}{dt^2} \sin\theta = -(\sin\theta)\dot{\theta}^2 + (\cos\theta)\ddot{\theta}$$

we have

$$(M+m)\ddot{x} - ml(\sin\theta)\dot{\theta}^2 + ml(\cos\theta)\ddot{\theta} = u$$

For small  $\theta$  and small  $\dot{\theta}^2$ , we have

$$(M+m)\ddot{x} + ml\ddot{\theta} = u \quad (1)$$

For rotational motion:

$$J\ddot{\theta} = mgl\sin\theta - m\ddot{x}l\cos\theta$$

where

$$J = I + ml^2, \quad I = m\frac{l^2}{3}$$

Thus,

$$(I + ml^2)\ddot{\theta} = mgl\sin\theta - m\ddot{x}l\cos\theta$$

For small  $\theta$ , we have

$$(I + ml^2)\ddot{\theta} = mgl\theta - ml\ddot{x} \quad (2)$$

From Equation (2),

$$\ddot{x} = g\theta - \frac{I + ml^2}{ml}\ddot{\theta}$$

Substituting this last equation into Equation (1), we obtain

$$(M+m)\left(g\theta - \frac{I + ml^2}{ml}\ddot{\theta}\right) + ml\ddot{\theta} = u$$

or

$$(M+m)g\theta - \frac{(M+m)I + Mml^2}{ml}\ddot{\theta} = u$$

Thus,

$$\ddot{\theta} = \frac{ml(M+m)g}{(M+m)I + Mml^2}\theta - \frac{ml}{(M+m)I + Mml^2}u \quad (3)$$

Also, from Equation (1) we have

$$(M+m)\ddot{x} + ml\frac{mgl\theta - ml\ddot{x}}{I + ml^2} = u$$

or

$$[MI + m(I + Ml^2)]\ddot{x} + m^2l^2g\theta = u(I + ml^2)$$

from which we get

$$\ddot{x} = - \frac{m^2 l^2 g}{MI + m(I + Ml^2)} \theta + \frac{I + ml^2}{MI + m(I + Ml^2)} u \quad (4)$$

Equations (3) and (4) describe the system dynamics in terms of differential equations.

By taking the Laplace transform of Equation (3), we obtain

$$\left[ s^2 - \frac{ml(M+m)g}{(M+m)I + Mml^2} \right] \Theta(s) = - \frac{ml}{(M+m)I + Mml^2} U(s)$$

or

$$\left\{ [MI + m(I + Ml^2)] s^2 - ml(M+m)g \right\} \Theta(s) = -ml U(s)$$

Hence

$$\frac{\Theta(s)}{U(s)} = - \frac{ml}{[MI + m(I + Ml^2)] s^2 - ml(M+m)g} \quad (5)$$

By taking the Laplace transform of Equation (4), we get

$$s^2 X(s) = - \frac{m^2 l^2 g}{MI + m(I + Ml^2)} \Theta(s) + \frac{I + ml^2}{MI + m(I + Ml^2)} U(s)$$

Hence

$$\frac{s^2 X(s)}{U(s)} = - \frac{m^2 l^2 g}{MI + m(I + Ml^2)} \frac{\Theta(s)}{U(s)} + \frac{I + ml^2}{MI + m(I + Ml^2)}$$

or

$$\begin{aligned} \frac{X(s)}{U(s)} &= \frac{m^2 l^2 g}{[MI + m(I + Ml^2)] s^2} \frac{\Theta(s)}{U(s)} + \frac{ml}{[MI + m(I + Ml^2)] s^2 - ml(M+m)g} \\ &+ \frac{I + ml^2}{[MI + m(I + Ml^2)] s^2} \end{aligned} \quad (6)$$

Equations (5) and (6) define the inverted pendulum control system in terms of transfer functions.

Next, we shall obtain a state-space representation of the system. Define state variables by

$$x_1 = \theta$$

$$x_2 = \dot{\theta}$$

$$x_3 = x$$

$$x_4 = \dot{x}$$

and output variables by

$$y_1 = \theta = x_1$$

$$y_2 = \chi = x_3$$

Then, from the definition of state variables and Equations (3) and (4), the state equation and output equation can be written as

$$\begin{bmatrix} \dot{x}_1 \\ \dot{x}_2 \\ \dot{x}_3 \\ \dot{x}_4 \end{bmatrix} = \begin{bmatrix} 0 & 1 & 0 & 0 \\ \frac{mL(M+m)g}{MI+m(I+ML^2)} & 0 & 0 & 0 \\ 0 & 0 & 0 & 1 \\ -\frac{m^2L^2g}{MI+m(I+ML^2)} & 0 & 0 & 0 \end{bmatrix} \begin{bmatrix} x_1 \\ x_2 \\ x_3 \\ x_4 \end{bmatrix} + \begin{bmatrix} 0 \\ \frac{mL}{MI+m(I+ML^2)} \\ 0 \\ \frac{I+mL^2}{MI+m(I+ML^2)} \end{bmatrix} u$$

$$\begin{bmatrix} y_1 \\ y_2 \end{bmatrix} = \begin{bmatrix} 1 & 0 & 0 & 0 \\ 0 & 0 & 1 & 0 \end{bmatrix} \begin{bmatrix} x_1 \\ x_2 \\ x_3 \\ x_4 \end{bmatrix}$$

**B-3-18.** The equations for the system are

$$m_1 \ddot{x}_1 = -k_1 x_1 - b_1 \dot{x}_1 - k_3 (x_1 - x_2) + u$$

$$m_2 \ddot{x}_2 = -k_2 x_2 - b_2 \dot{x}_2 - k_3 (x_2 - x_1)$$

Rewriting, we have

$$m_1 \ddot{x}_1 + b_1 \dot{x}_1 + k_1 x_1 + k_3 x_1 = k_3 x_2 + u$$

$$m_2 \ddot{x}_2 + b_2 \dot{x}_2 + k_2 x_2 + k_3 x_2 = k_3 x_1$$

Assuming the zero initial condition and taking the Laplace transforms of these two equations, we obtain

$$(m_1 s^2 + b_1 s + k_1 + k_3) X_1(s) = k_3 X_2(s) + U(s) \quad (1)$$

$$(m_2 s^2 + b_2 s + k_2 + k_3) X_2(s) = k_3 X_1(s) \quad (2)$$

By eliminating  $X_2(s)$  from Equations (1) and (2), we get

$$(m_1 s^2 + b_1 s + k_1 + k_3) X_1(s) = \frac{k_3^2}{m_2 s^2 + b_2 s + k_2 + k_3} X_1(s) + U(s)$$

Hence

$$\frac{X_1(s)}{U(s)} = \frac{m_2 s^2 + b_2 s + k_2 + k_3}{(m_1 s^2 + b_1 s + k_1 + k_3)(m_2 s^2 + b_2 s + k_2 + k_3) - k_3^2}$$

From Equation (2), we obtain

$$\frac{X_2(s)}{X_1(s)} = \frac{k_3}{m_2 s^2 + b_2 s + k_2 + k_3}$$

Hence

$$\frac{X_2(s)}{U(s)} = \frac{X_2(s)}{X_1(s)} \cdot \frac{X_1(s)}{U(s)} = \frac{k_3}{(m_1 s^2 + b_1 s + k_1 + k_3)(m_2 s^2 + b_2 s + k_2 + k_3) - k_3^2}$$

---

**B-3-19.** The equations for the given circuit are as follow:

$$R_1 i_1 + L \left( \frac{di_1}{dt} - \frac{di_2}{dt} \right) = e_i$$

$$R_2 i_2 + \frac{1}{C} \int i_2 dt + L \left( \frac{di_2}{dt} - \frac{di_1}{dt} \right) = 0$$

$$\frac{1}{C} \int i_2 dt = e_o$$

Taking the Laplace transforms of these three equations, assuming zero initial conditions, gives

$$R_1 I_1(s) + L [s I_1(s) - s I_2(s)] = E_i(s) \quad (1)$$

$$R_2 I_2(s) + \frac{1}{Cs} I_2(s) + L [s I_2(s) - s I_1(s)] = 0 \quad (2)$$

$$\frac{1}{Cs} I_2(s) = E_o(s) \quad (3)$$

From Equation (2) we obtain

$$\left( R_2 + \frac{1}{Cs} + Ls \right) I_2(s) = Ls I_1(s)$$

or

$$I_2(s) = \frac{LCs^2}{LCs^2 + R_2Cs + 1} I_1(s) \quad (4)$$

Substituting Equation (4) into Equation (1), we get

$$\left( R_1 + Ls - Ls \frac{LCs^2}{LCs^2 + R_2Cs + 1} \right) I_1(s) = E_i(s)$$

or

$$\frac{LC(R_1 + R_2)s^2 + (R_1R_2C + L)s + R_1}{LCs^2 + R_2Cs + 1} I_1(s) = E_i(s) \quad (5)$$

From Equations (3) and (4), we have

$$\frac{Ls}{LCs^2 + R_2Cs + 1} I_1(s) = E_o(s) \quad (6)$$

From Equations (5) and (6), we obtain

$$\frac{E_o(s)}{E_i(s)} = \frac{Ls}{LC(R_1 + R_2)s^2 + (R_1R_2C + L)s + R_1}$$

---

**B-3-20.** Equations for the circuit are

$$\frac{1}{C_1} \int (i_1 - i_2) dt + R_1 i_1 = e_i$$

$$\frac{1}{C_1} \int (i_2 - i_1) dt + R_2 i_2 + \frac{1}{C_2} \int i_2 dt = 0$$

$$\frac{1}{C_2} \int i_2 dt = e_o$$

The Laplace transforms of these three equations, with zero initial conditions, are

$$\frac{1}{C_1 s} [I_1(s) - I_2(s)] + R_1 I_1(s) = E_i(s) \quad (1)$$

$$\frac{1}{C_1 s} [I_2(s) - I_1(s)] + R_2 I_2(s) + \frac{1}{C_2 s} I_2(s) = 0 \quad (2)$$

$$\frac{1}{C_2 s} I_2(s) = E_o(s) \quad (3)$$

Equation (1) can be rewritten as

$$C_1 s [E_i(s) - R_1 I_1(s)] = I_1(s) - I_2(s) \quad (4)$$

Equation (4) gives the block diagram shown in Figure (a). Equation (2) can be modified to

$$I_2(s) = \frac{C_2 s}{R_2 C_2 s + 1} \frac{1}{C_1 s} [I_1(s) - I_2(s)] \quad (5)$$

Equation (5) yields the block diagram shown in Figure (b). Also, Equation (3) gives the block diagram shown in Figure (c). Combining the block diagrams of Figures (a), (b), and (c), we obtain Figure (d). This block diagram can be successively modified as shown in Figures (e) through (h). In this way, we can obtain the transfer function  $E_o(s)/E_i(s)$  of the given circuit.

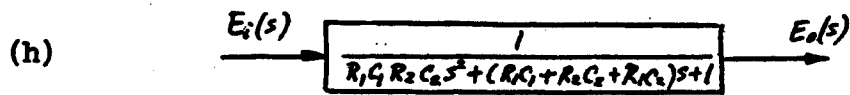
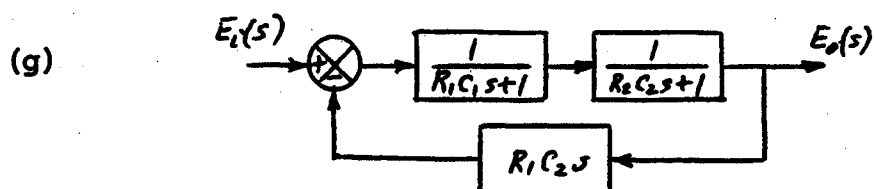
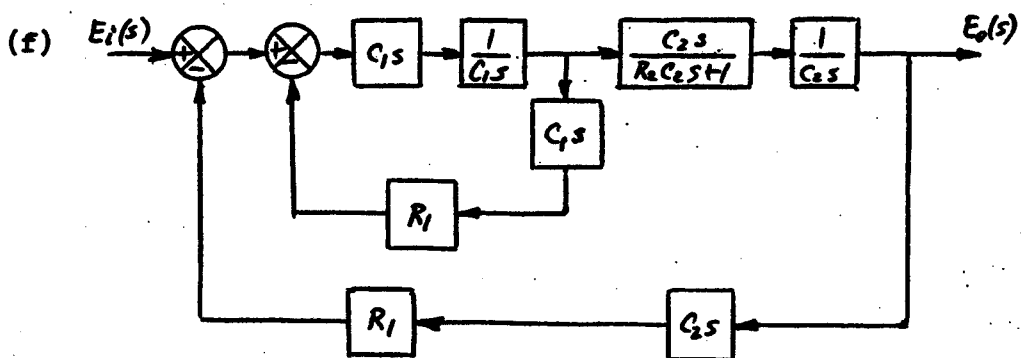
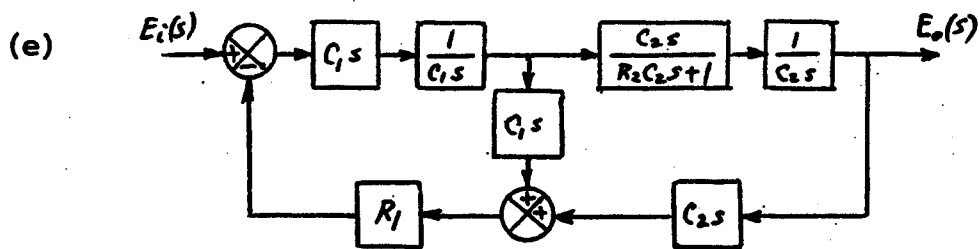
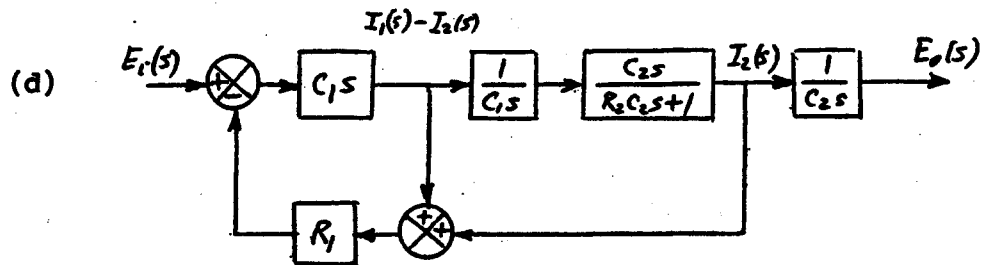
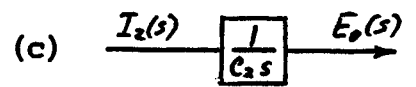
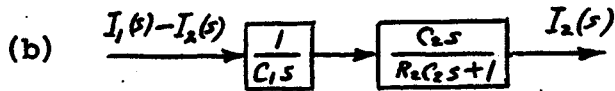
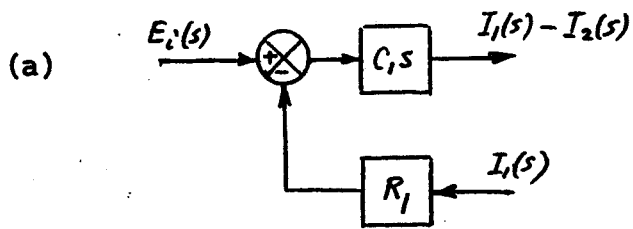

B-3-21. Impedance  $Z_1$  is

$$Z_1 = R_1 + \frac{1}{C_1 s}$$

Impedance  $Z_2$  is

$$Z_2 = R_2 + \frac{1}{C_2 s}$$

Hence

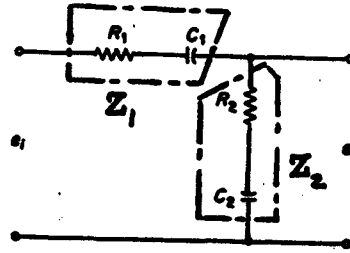

$$\begin{aligned} \frac{E_o(s)}{E_i(s)} &= \frac{Z_2}{Z_1 + Z_2} = \frac{R_2 + \frac{1}{C_2 s}}{R_1 + \frac{1}{C_1 s} + R_2 + \frac{1}{C_2 s}} \\ &= \frac{R_2 C_2 s + 1}{(R_1 C_2 + R_2 C_2) s + 1 + \frac{C_2}{C_1}} \end{aligned}$$

If we change  $R_1$  to  $b_1$ ,  $R_2$  to  $b_2$ ,  $C_1$  to  $1/k_1$ ,  $C_2$  to  $1/k_2$ , then we obtain

$$\frac{R_2 C_2 s + 1}{(R_1 + R_2) C_2 s + 1 + \frac{C_2}{C_1}} = \frac{b_2 \frac{1}{k_2} s + 1}{(b_1 + b_2) \frac{1}{k_2} s + 1 + \frac{k_1}{k_2}}$$

or

$$\frac{X_o(s)}{X_i(s)} = \frac{b_2 s + k_2}{(b_1 + b_2) s + k_2 + k_1} = \frac{b_2 s + k_2}{(b_1 s + k_1) + (b_2 s + k_2)}$$

The analogous mechanical system is shown below.

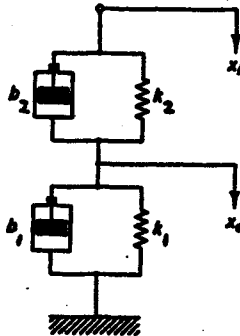

B-3-22.

$$Z_1 = R_1 + \frac{1}{Cs}$$

$$Z_2 = R_2$$

Then

$$E_i(s) = \left( R_1 + \frac{1}{Cs} \right) I(s)$$

$$E_o(s) = -R_2 I(s)$$

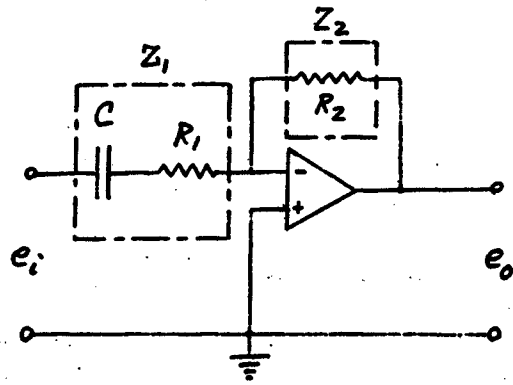

Hence

$$\frac{E_o(s)}{E_i(s)} = -\frac{R_2}{R_1 + \frac{1}{Cs}} = -\frac{R_2 Cs}{R_1 Cs + 1}$$

B-3-23. Define the voltage at point A as  $e_A$ . Then

$$\frac{E_A(s)}{E_i(s)} = \frac{R_1}{\frac{1}{Cs} + R_1} = \frac{R_1 Cs}{R_1 Cs + 1}$$

Define the voltage at point B as  $e_B$ . Then

$$E_B(s) = \frac{R_3}{R_2 + R_3} E_o(s)$$

Noting that

$$\left[ E_A(s) - E_B(s) \right] K = E_o(s)$$

and  $K \gg 1$ , we must have

$$E_A(s) = E_B(s)$$

Hence

$$E_A(s) = \frac{R_1 Cs}{R_1 Cs + 1} E_i(s) = E_B(s) = \frac{R_3}{R_2 + R_3} E_o(s)$$

from which we obtain

$$\frac{E_o(s)}{E_i(s)} = \frac{R_2 + R_3}{R_3} \frac{R_1 Cs}{R_1 Cs + 1} = \frac{\left(1 + \frac{R_2}{R_3}\right)s}{s + \frac{1}{R_1 C}}$$

**B-3-24.** For the op-amp circuit shown to the right, we have

$$E_A - E_O = Z_4 I_2$$

$$E_B - 0 = Z_3 I_1$$

$$E_A = E_B$$

Hence

$$Z_4 I_2 + E_O = Z_3 I_1$$

or

$$I_2 = \frac{1}{Z_4} (Z_3 I_1 - E_O) \quad (1)$$

Also,

$$E_i - E_O = (Z_2 + Z_4) I_2 \quad (2)$$

$$E_i = (Z_1 + Z_3) I_1 \quad (3)$$

By substituting Equation (1) into Equation (2), we obtain

$$E_i - E_O = (Z_2 + Z_4) \frac{1}{Z_4} (Z_3 I_1 - E_O)$$

By substituting Equation (3) into this last equation, we get

$$(Z_1 + Z_3) I_1 - E_O = \left( \frac{Z_2}{Z_4} + 1 \right) Z_3 I_1 - \left( \frac{Z_2}{Z_4} + 1 \right) E_O$$

or

$$\left( 1 - \frac{Z_2}{Z_4} - 1 \right) E_O = \left( Z_1 + Z_3 - \frac{Z_2 Z_3}{Z_4} - Z_3 \right) I_1$$

Hence

$$-Z_2 E_O = (Z_1 Z_4 - Z_2 Z_3) I_1 \quad (4)$$

From Equations (3) and (4), we have

$$\frac{E_O}{E_i} = \frac{\frac{Z_2 Z_3 - Z_1 Z_4}{Z_2}}{Z_1 + Z_3} = \frac{Z_2 Z_3 - Z_1 Z_4}{Z_1 Z_2 + Z_2 Z_3}$$

For the current op-amp circuit, we have

$$Z_1 = \frac{1}{Cs}, \quad Z_2 = R_1, \quad Z_3 = R_2, \quad Z_4 = R_1$$

Hence

$$\frac{E_O(s)}{E_i(s)} = \frac{R_1 R_2 - \frac{1}{Cs} R_1}{\frac{1}{Cs} R_1 + R_1 R_2} = \frac{R_2 - \frac{1}{Cs}}{\frac{1}{Cs} + R_2} = \frac{R_2 Cs - 1}{R_2 Cs + 1}$$

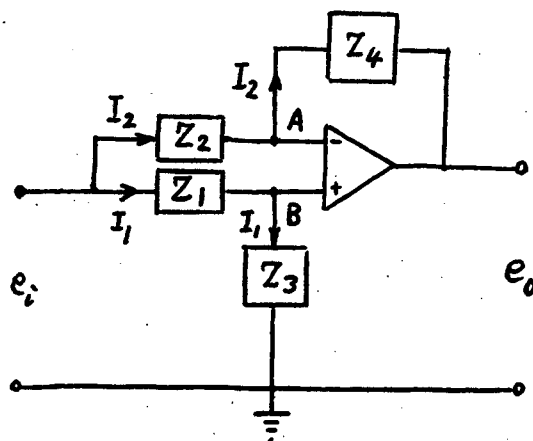

B-3-25. Define the current in the armature circuit to be  $i_a$ . Then, we have

$$L \frac{di_a}{dt} + R i_a + K_b \frac{d\theta_m}{dt} = e_i$$

or

$$(Ls + R) I_a(s) + K_b s \Theta_m(s) = E_i(s) \quad (1)$$

where  $K_b$  is the back emf constant of the motor. We also have

$$J_m \ddot{\theta}_m + T = T_m = K i_a \quad (2)$$

$$T = \frac{\theta}{\theta_m} T_L = n T_L$$

$$J_L \ddot{\theta} = T_L$$

where  $K$  is the motor torque constant and  $i_a$  is the armature current. Equation (2) can be rewritten as

$$(J_m + n^2 J_L) \ddot{\theta} = n K i_a$$

or

$$(J_m + n^2 J_L) s^2 \Theta(s) = n K I_a(s) \quad (3)$$

By substituting Equation (3) into Equation (1), we obtain

$$(Ls + R) \frac{(J_m + n^2 J_L) s^2}{nK} \Theta(s) + K_b s \frac{\Theta(s)}{n} = E_i(s)$$

or

$$\left[ (Ls + R)(J_m + n^2 J_L) s^2 + K K_b s \right] \Theta(s) = n K E_i(s)$$

Hence

$$\frac{\Theta(s)}{E_i(s)} = \frac{nK}{s \left[ (Ls + R)(J_m + n^2 J_L) s + K K_b \right]}$$

B-3-26. We shall use Mason's gain formula to obtain  $Y(s)/X(s)$ .

$$P = \frac{1}{\Delta} \sum_k P_k \Delta_k = \frac{1}{\Delta} (P_1 \Delta_1 + P_2 \Delta_2)$$

where

$$P_1 = \frac{b_2}{s^2}, \quad P_2 = \frac{b_1}{s}$$

Also,

$$\Delta = 1 - (L_1 + L_2)$$

where

$$L_1 = -\frac{a_1}{s}, \quad L_2 = -\frac{a_2}{s^2}$$

Hence

$$\Delta = 1 - (L_1 + L_2) = 1 + \frac{a_1}{s} + \frac{a_2}{s^2} = \frac{s^2 + a_1 s + a_2}{s^2}$$

Also,

$$\Delta_1 = 1, \quad \Delta_2 = 1$$

Hence,

$$P = \frac{s^2}{s^2 + a_1 s + a_2} \left( \frac{b_2}{s^2} + \frac{b_1}{s} \right) = \frac{b_1 s + b_2}{s^2 + a_1 s + a_2}$$

**B-3-27.** We shall use Mason's gain formula to obtain  $Y(s)/X(s)$ .

$$P = \frac{1}{\Delta} \sum_K P_K \Delta_K = \frac{1}{\Delta} (P_1 \Delta_1 + P_2 \Delta_2 + P_3 \Delta_3)$$

where

$$P_1 = \frac{b_3}{s^3}, \quad P_2 = \frac{b_1}{s}, \quad P_3 = \frac{b_2}{s^2}$$

Also,

$$\Delta = 1 - (L_1 + L_2 + L_3)$$

where

$$L_1 = \frac{-a_1}{s}, \quad L_2 = \frac{-a_2}{s^2}, \quad L_3 = \frac{-a_3}{s^3}$$

Hence

$$\Delta = 1 + \frac{a_1}{s} + \frac{a_2}{s^2} + \frac{a_3}{s^3} = \frac{s^3 + a_1 s^2 + a_2 s + a_3}{s^3}$$

Also,

$$\Delta_1 = 1, \quad \Delta_2 = 1, \quad \Delta_3 = 1$$

Hence,

$$\begin{aligned} P &= \frac{s^3}{s^3 + a_1 s^2 + a_2 s + a_3} \left( \frac{b_3}{s^3} + \frac{b_1}{s} + \frac{b_2}{s^2} \right) \\ &= \frac{s^3}{s^3 + a_1 s^2 + a_2 s + a_3} \frac{b_1 s^2 + b_2 s + b_3}{s^3} \\ &= \frac{b_1 s^2 + b_2 s + b_3}{s^3 + a_1 s^2 + a_2 s + a_3} \end{aligned}$$

**B-3-28.** Define

$$z = x^2 + 8xy + 3y^2 = f(x, y)$$

$$2 \leq x \leq 4, \quad 10 \leq y \leq 12$$

Let us choose  $\bar{x} = 3$  and  $\bar{y} = 11$ . Then

$$\bar{z} = \bar{x}^2 + 8\bar{x}\bar{y} + 3\bar{y}^2 = 9 + 264 + 363 = 636$$

We shall obtain a linearized equation for the nonlinear equation near the point  $\bar{x} = 3$ ,  $\bar{y} = 11$ . Expanding the nonlinear equation into a Taylor series about point  $x = \bar{x}$ ,  $y = \bar{y}$  and neglecting the higher-order terms, we obtain

$$z - \bar{z} = K_1 (x - \bar{x}) + K_2 (y - \bar{y})$$

where

$$K_1 = \left. \frac{\partial f}{\partial x} \right|_{x=\bar{x}, y=\bar{y}} = 2\bar{x} + 8\bar{y} \Big|_{\bar{x}=3, \bar{y}=11} = 6 + 88 = 94$$

$$K_2 = \left. \frac{\partial f}{\partial y} \right|_{x=\bar{x}, y=\bar{y}} = 8\bar{x} + 6\bar{y} \Big|_{\bar{x}=3, \bar{y}=11} = 24 + 66 = 90$$

Hence the linearized equation is

$$z - 636 = 94(x - 3) + 90(y - 11)$$

or

$$z = 94x + 90y - 636$$

---

B-3-29. Define

$$y = 0.2x^3 = f(x), \quad \bar{x} = 2$$

Then

$$y = f(x) = f(\bar{x}) + \frac{\partial f}{\partial x} (x - \bar{x}) + \dots$$

Since the higher-order terms in this equation are small, neglecting those terms, we obtain

$$y - f(\bar{x}) = 0.6\bar{x}^2(x - \bar{x})$$

or

$$y - 0.2 \times 2^3 = 0.6 \times 2^2 (x - 2)$$

Thus, linear approximation of the given nonlinear equation near the operating point is

$$y = 2.4x - 3.2$$

---

# CHAPTER 4

B-4-1.

$$C dh = (q_i - q_o) dt, \quad R = \frac{dH}{dQ} = \frac{h}{q_o}, \quad Q = K\sqrt{H}$$

Thus

$$CR \frac{dh}{dt} + h = R q_i$$

Note that

$$dQ = K \frac{1}{2} \frac{dH}{\sqrt{H}}$$

Hence

$$R = \frac{dH}{dQ} = \frac{2\sqrt{H}}{K}$$

Since

$$K = \frac{Q}{\sqrt{H}} = \frac{0.02}{\sqrt{3}}$$

we have

$$R = \frac{2\sqrt{3}}{\frac{0.02}{\sqrt{3}}} = 300$$

Thus,

$$\text{Time constant} = CR = 5 \times 300 = 1500 \text{ sec}$$

B-4-2. For this system

$$C dH = -Q dt, \quad H = 3r, \quad C = r^2 \pi = \left(\frac{H}{3}\right)^2 \pi$$

Hence

$$\left(\frac{H}{3}\right)^2 \pi dH = -0.005 \sqrt{H} dt$$

or

$$H^{\frac{5}{2}} dH = -0.005 \frac{9}{\pi} dt$$

Assume that the head moves down from  $H = 2\text{m}$  to  $x$  for the 60 sec period. Then

$$\int_2^x H^{\frac{5}{2}} dH = -0.005 \frac{9}{\pi} \int_0^{60} dt$$

or

$$\frac{2}{5} (x^{\frac{5}{2}} - 2^{\frac{5}{2}}) = -0.01432 (60 - 0)$$

which can be rewritten as

$$x^{\frac{5}{2}} - (1.414213)^5 = -2.1480$$

or

$$x^{\frac{5}{2}} = 5.65685 - 2.1480 = 3.5089$$

Taking logarithms of both sides of this last equation, we obtain

$$\frac{5}{2} \log_{10} x = \log_{10} 3.5089$$

or

$$x = 1.652 \text{ m}$$

B-4-3. From Figure 4-49 we obtain the following equations:

$$\frac{H_1(s) - H_2(s)}{R_1} = Q_1(s)$$

$$\frac{H_2(s)}{R_2} = Q_2(s)$$

$$\frac{Q_1(s) - Q_2(s)}{C_1 s} = H_1(s)$$

$$\frac{Q_1(s) - Q_2(s) + Q_1(s)}{C_2 s} = H_2(s)$$

For each of the above equations, a block diagram can be drawn, as shown next.

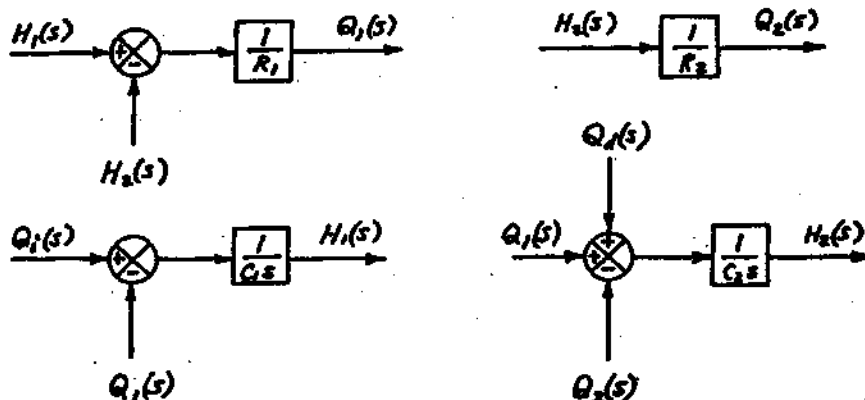

Combining these elements of block diagrams, we obtain a block diagram for the system as shown below.

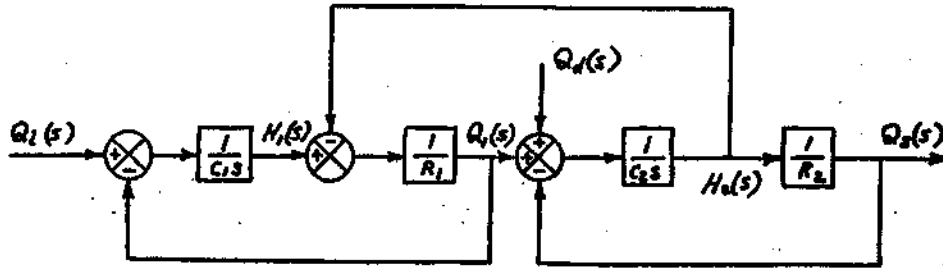

Simplifying this block diagram successively, we obtain a reasonably simplified block diagram as follows:

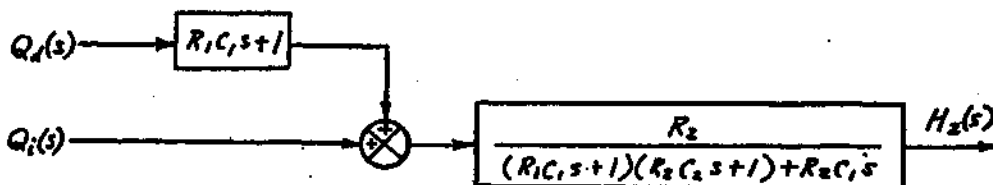
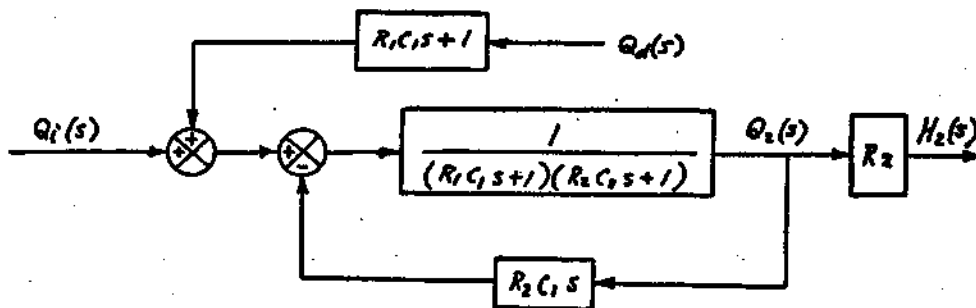
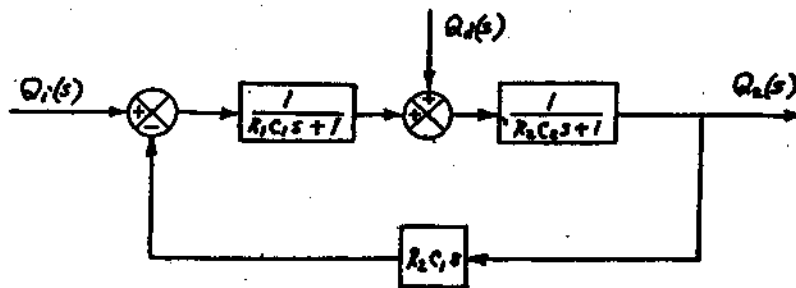
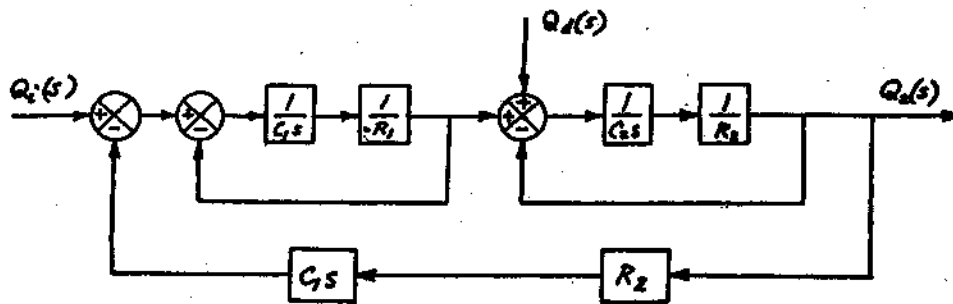

From this last block diagram we obtain  $H_2(s)$  as a function of  $Q_1(s)$  and  $Q_d(s)$  as follows:

$$H_2(s) = \frac{R_2}{(R_1 C_1 s + 1)(R_2 C_2 s + 1) + R_2 C_1 s} [Q_1(s) + (R_1 C_1 s + 1)Q_d(s)]$$

**B-4-4.** Figure (a) below is a block diagram of the given system when changes in the variables are small. Since the set point of the controller is fixed,  $r = 0$ . (Note that  $r$  is the change in the set point.) To investigate the response of the level of the second tank subjected to a unit-step disturbance input  $q_d$ , we find it convenient to modify the block diagram of Figure (a) to the one shown in Figure (b).

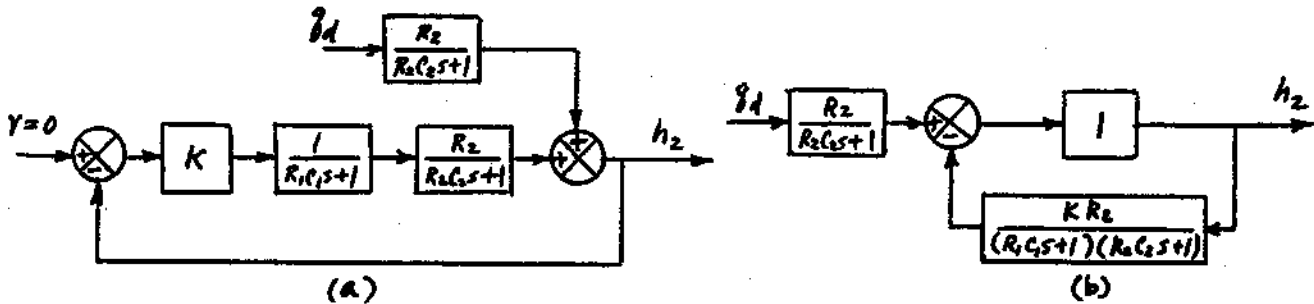

The transfer function between  $H_2(s)$  and  $Q_d(s)$  can be obtained as

$$\frac{H_2(s)}{Q_d(s)} = \frac{R_2 (R_1 C_1 s + 1)}{(R_1 C_1 s + 1)(R_2 C_2 s + 1) + K R_2}$$

From this equation, the response  $H_2(s)$  to the disturbance input  $Q_d(s)$  can be obtained. For the unit-step disturbance input  $Q_d(s)$ , we obtain

$$h_2(\infty) = \lim_{s \rightarrow 0} s H_2(s) = \frac{R_2}{1 + K R_2}$$

or

$$\text{steady-state error} = - \frac{R_2}{1 + K R_2}$$

The system exhibits offset in the response to a unit-step disturbance input.

**B-4-5.** Note that

$$C dp_0 = q dt$$

where  $q$  is the flow rate through the valve and is given by

$$q = \frac{P_i - P_o}{R}$$

Hence

$$C \frac{dp_o}{dt} = \frac{P_i - P_o}{R}$$

from which we obtain

$$\frac{P_o(s)}{P_i(s)} = \frac{1}{RCs+1}$$

For the bellows and spring, we have the following equation:

$$AP_o = kx$$

The transfer function  $X(s)/P_i(s)$  is then given by

$$\frac{X(s)}{P_i(s)} = \frac{X(s)}{P_o(s)} \frac{P_o(s)}{P_i(s)} = \frac{A}{k} \frac{1}{RCs+1}$$

B-4-6.

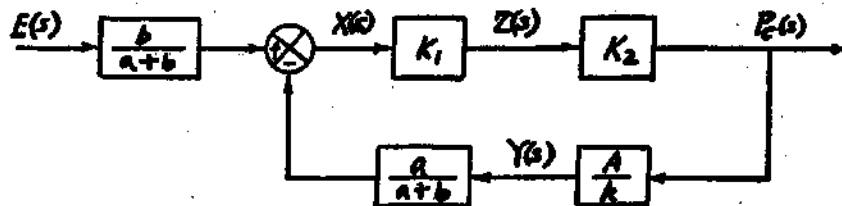

In this block diagram,  $Z(s)$  is the Laplace transform of the small displacement of the diaphragm of the pneumatic relay. The transfer function  $P_c(s)/E(s)$  is given by

$$\frac{P_c(s)}{E(s)} = \frac{b}{a+b} \frac{K_1 K_2}{1 + K_1 K_2 \frac{a}{a+b} \frac{A}{k}} = K_p$$

The control action of this controller is proportional. Thus, the controller is a proportional controller.

B-4-7. Define the pressure of air in the bellows as  $\bar{P}_c + P_o$ . Then

$$C dp_o = g dt, \quad g = \frac{P_c - P_o}{R}$$

Hence

$$C \frac{dP_o}{dt} = \frac{P_c - P_o}{R}$$

or

$$RC \frac{dP_o}{dt} + P_o = P_c \quad (1)$$

Define the area of bellows as  $A$  and the displacement of the bellows as  $\bar{Y} + y$ . Then, noting that  $P_o A = ky$ , Equation (1) becomes as

$$RC \frac{k}{A} \frac{dy}{dt} + \frac{k}{A} y = P_c$$

or

$$RC \frac{dy}{dt} + y = \frac{A}{k} p_c$$

Thus

$$\frac{Y(s)}{P_c(s)} = \frac{\frac{A}{k}}{RCs + 1}$$

A block diagram for this system is shown below.

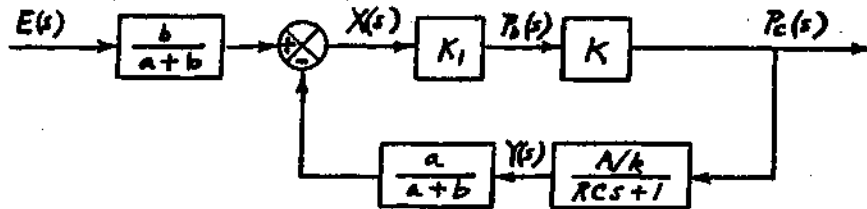

$$\frac{P_c(s)}{E(s)} = \frac{b}{a+b} \frac{K_i K}{1 + K_i K \frac{a}{a+b} \frac{A/k}{RCs+1}}$$

Assume that  $K_i K \gg 1$ . Then

$$\frac{P_c(s)}{E(s)} = \frac{b}{a+b} \frac{a+b}{a} \frac{RCs+1}{\frac{A}{k}} = \left( \frac{bk}{aA} \right) (RCs+1)$$

Thus, the control action is proportional-plus-derivative. The controller is a proportional-plus-derivative controller.

B-4-8.

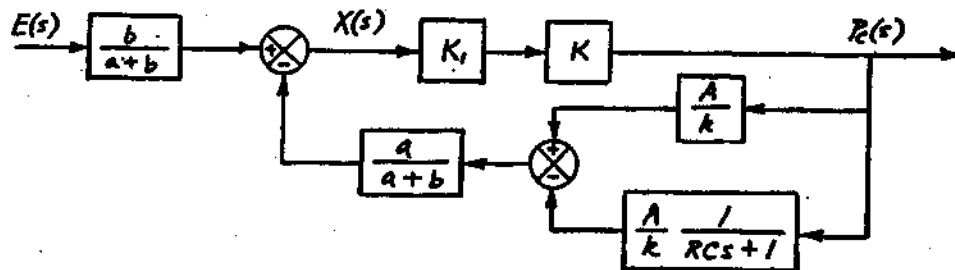

$$\frac{P_c(s)}{E(s)} = \frac{b}{a+b} \frac{K_i K}{1 + \frac{K_i K A}{a+b} \left( \frac{A}{k} - \frac{A}{k} \frac{1}{RCs+1} \right)}$$

If  $K_i K \gg 1$ , then

$$\frac{P_c(s)}{E(s)} = \frac{b}{a+b} \frac{K_1 K}{\frac{K_1 K a}{a+b} \frac{A}{k} \frac{RCs}{RCs+1}} = \left(\frac{bk}{aA}\right) \left(1 + \frac{1}{RCs}\right)$$

The controller is a proportional-plus-integral controller.

**B-4-9.**

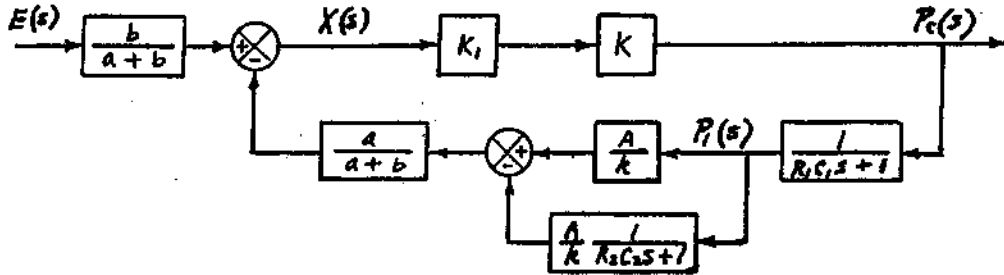

$$\frac{P_c(s)}{E(s)} = \frac{b}{a+b} \frac{K_1 K}{1 + K_1 K \frac{a}{a+b} \frac{A}{k} \frac{R_2 C_2 s}{R_2 C_2 s + 1} \frac{1}{R_1 C_1 s + 1}}$$

If  $K_1 K \gg 1$ , then

$$\begin{aligned} \frac{P_c(s)}{E(s)} &= \frac{b}{a+b} \frac{1}{\frac{a}{a+b} \frac{A}{k} \frac{R_2 C_2 s}{R_2 C_2 s + 1} \frac{1}{R_1 C_1 s + 1}} \\ &= \left(\frac{bk}{aA}\right) \left(\frac{R_2 C_2 s + 1}{R_2 C_2 s}\right) (R_1 C_1 s + 1) \\ &= \frac{bk}{aA} \left(1 + \frac{1}{R_2 C_2 s}\right) (R_1 C_1 s + 1) \\ &= \frac{bk}{aA} \left(1 + \frac{R_1 C_1}{R_2 C_2} + \frac{1}{R_2 C_2 s} + R_1 C_1 s\right) \end{aligned}$$

Thus, the control action is proportional-plus-integral-plus-derivative. The controller is a PID controller.

**B-4-10.** Referring to the figure shown on the next page, we can obtain the equations for the system.

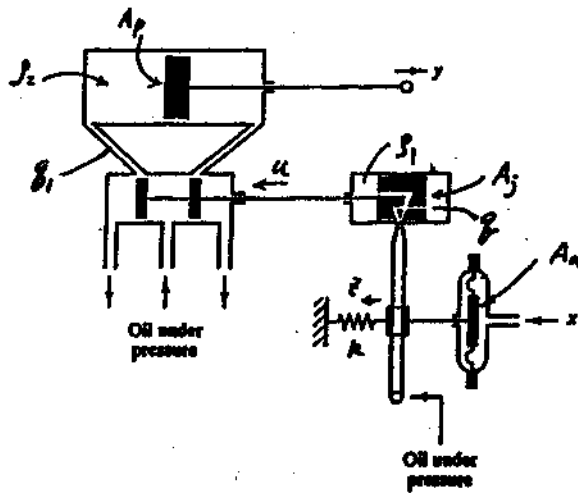

For the diaphragm and spring assembly,

$$A_d x = k z$$

or

$$\frac{Z(s)}{X(s)} = \frac{A_d}{k}$$

For the jet pipe,

$$q = K_1 z, \quad A_j p_1 du = q dt$$

$$\frac{du}{dt} = \frac{q}{A_j p_1} = \frac{K_1}{A_j p_1} z$$

or

$$\frac{U(s)}{Z(s)} = \frac{K_1}{A_j p_1 s}$$

For the pilot valve,

$$A_p p_2 dy = q_1 dt, \quad q_1 = K_2 u$$

$$\frac{dy}{dt} = \frac{q_1}{A_p p_2} = \frac{K_2 u}{A_p p_2}$$

or

$$\frac{Y(s)}{U(s)} = \frac{K_2}{A_p p_2 s}$$

A simplified block diagram for the system is shown below.

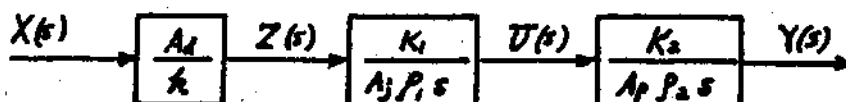

From this block diagram we obtain

$$\frac{Y(s)}{X(s)} = \frac{Y(s) U(s) Z(s)}{U(s) Z(s) X(s)} = \frac{K_2}{A_p \beta_2 s} \frac{K_1}{A_j \beta_1 s} \frac{A_d}{k} = \frac{K}{s^2}$$

where

$$K = \frac{K_2 K_1 A_d}{A_p \beta_2 A_j \beta_1 k}$$

**B-4-11.** Define displacements  $e$ ,  $x$ , and  $y$  as shown in the figure below.

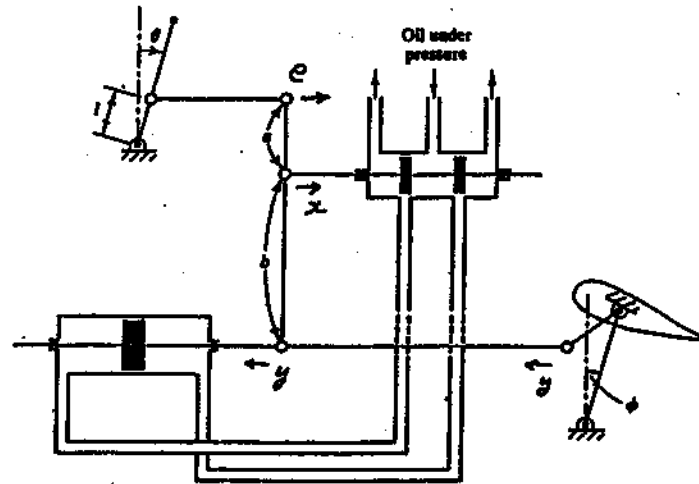

From this figure we can construct a block diagram as shown below.

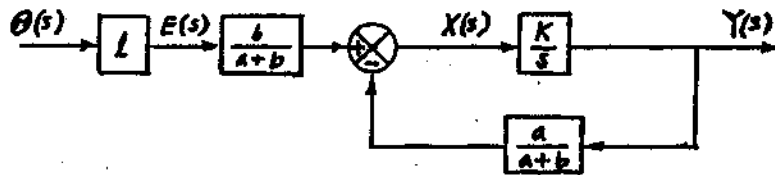

From the block diagram we obtain the transfer function  $Y(s)/\theta(s)$  as follows:

$$\frac{Y(s)}{\theta(s)} = \frac{l \frac{b}{a+b} \frac{K}{s}}{1 + \frac{K}{s} \frac{a}{a+b}} = \frac{lb}{a+b} \frac{a+b}{a} = l \frac{b}{a}$$

We see that the piston displacement  $y$  is proportional to the deflection angle  $\theta$  of the control lever. Also, from the system diagram we see that for each value of  $y$ , there is a corresponding value of angle  $\phi$ . Therefore, for each angle  $\theta$  of the control lever, there is a corresponding steady-state elevator angle  $\phi$ .

**B-4-12.** Since the increase of water in the tank during  $dt$  seconds is equal to the net inflow to the tank during the same  $dt$  seconds, we have

$$C dh = (q_i + q_d - q_o) dt \quad (1)$$

where

$$q_o = \frac{h}{R}$$

For the feedback lever mechanism, we have

$$x = \frac{a}{a+b} h$$

Equation (1) can now be written as follows:

$$C \frac{dh}{dt} = q_i + q_d - q_o = -K_v y + q_d - \frac{h}{R} \quad (2)$$

Note that

$$\frac{dy}{dt} = K_1 x = K_1 \frac{a}{a+b} h \quad (3)$$

By substituting the given numerical values into Equations (2) and (3), we obtain

$$2 \frac{dh}{dt} = -y + q_d - 2h$$

$$\frac{dy}{dt} = h$$

Taking the Laplace transforms of the preceding two equations, assuming zero initial conditions, we obtain

$$2s H(s) = -Y(s) + Q_d(s) - 2H(s)$$

$$s Y(s) = H(s)$$

By eliminating  $Y(s)$  from the last two equations, we get

$$2s^2 H(s) = -H(s) + s Q_d(s) - 2s H(s)$$

Hence

$$(2s^2 + 2s + 1) H(s) = s Q_d(s)$$

from which we get

$$\frac{H(s)}{Q_d(s)} = \frac{s}{2s^2 + 2s + 1}$$

**B-4-13.** For the system

$$P_i A = k(x - z)$$

where  $A$  is the area of the bellows and  $z$  is the displacement of the lower end of the spring. Also,

$$y = K \int x dt, \quad y = -z$$

Thus

$$Y(s) = \frac{K}{s} X(s), \quad Y(s) = -Z(s)$$

Hence

$$AP_i(s) = k [X(s) - Z(s)] = k [X(s) + Y(s)] = k \left(1 + \frac{K}{s}\right) X(s)$$

Therefore,

$$\frac{Y(s)}{P_i(s)} = \frac{K X(s)}{s P_i(s)} = \frac{KA}{sk \left(1 + \frac{K}{s}\right)} = \frac{KA}{k(s+K)}$$

B-4-14. Define

$\theta_0$  = ambient temperature

$\theta_1$  = temperature of thermocouple

$\theta_2$  = temperature of thermal well

$R_1$  = thermal resistance of thermocouple

$R_2$  = thermal resistance of thermal well

$C_1$  = thermal capacitance of thermocouple

$C_2$  = thermal capacitance of thermal well

$h_1$  = heat input rate to thermocouple

$h_2$  = heat input rate to thermal well

Then, the equations for the system can be written as

$$C_1 d\theta_1 = h_1 dt$$

$$C_2 d\theta_2 = (h_2 - h_1) dt$$

where  $h_1 = (\theta_2 - \theta_1)/R_1$  and  $h_2 = (\theta_0 - \theta_2)/R_2$ . Thus we have

$$R_1 C_1 \frac{d\theta_1}{dt} + \theta_1 = \theta_2$$

$$C_2 \frac{d\theta_2}{dt} = \frac{\theta_0 - \theta_2}{R_2} - \frac{\theta_2 - \theta_1}{R_1}$$

By eliminating  $\theta_2$  from the last two equations, we obtain

$$\frac{\theta_1(s)}{\theta_0(s)} = \frac{1}{R_1 C_1 R_2 C_2 s^2 + (R_1 C_1 + R_2 C_2 + R_2 C_1) s + 1}$$

Noting that

$R_1 C_1$  = time constant of thermocouple = 2 sec

$R_2 C_2$  = time constant of thermal well = 30 sec

we have

$$R_2 C_1 = R_2 C_2 \frac{C_1}{C_2} = 30 \frac{8}{40} = 6 \text{ sec}$$

Hence the denominator of  $\theta_1(s)/\theta_2(s)$  becomes as

$$\begin{aligned} R_1 C_1 R_2 C_2 s^2 + (R_1 C_1 + R_2 C_2 + R_2 C_1) s + 1 \\ = 60 s^2 + 38 s + 1 = (1.65 s + 1)(36.35 s + 1) \end{aligned}$$

Thus, the time constants of the system are

$$T_1 = 1.651 \text{ sec}, \quad T_2 = 36.35 \text{ sec}$$

---

# CHAPTER 5

B-5-1. Time constant = 0.25 min. The steady-state error is 2.5 degrees.

---

B-5-2. Rise time = 2.42 sec  
Peak time = 3.63 sec  
Maximum overshoot = 0.163  
Settling time = 8 sec (2% criterion)

---

B-5-3. The maximum overshoot of 5% corresponds to  $\zeta = 0.69$ . Hence

$$\omega_n = \frac{2}{\zeta} = \frac{2}{0.69} = 2.90 \text{ rad/sec}$$

---

B-5-4.

$$\frac{C(s)}{R(s)} = \frac{K(Ts+1)}{Js^2 + KTs + K}$$

Since  $T = 3$ ,  $K/J = 2/9$ , we have

$$\frac{C(s)}{R(s)} = \frac{\frac{2}{9}(3s+1)}{s^2 + (\frac{2}{9})3s + \frac{2}{9}}$$

Hence,  $2\zeta\omega_n = 6/9$  and  $\omega_n^2 = 2/9$ . Thus

$$\zeta = 0.707$$

---

B-5-5. When the mass  $m$  is set into motion by a unit-impulse force, the system equation becomes

$$m\ddot{x} + kx = \delta(t)$$

Define another impulse force to stop the motion as  $A\delta(t-T)$ , where  $A$  is the undetermined magnitude of the impulse force and  $t = T$  is the undetermined instant that this impulse is to be given to the system. Then, the equation for the system when the two impulse forces are given is

$$m\ddot{x} + kx = \delta(t) + A\delta(t-T), \quad x(0^-) = 0, \quad \dot{x}(0^-) = 0$$

The Laplace transform of this last equation gives

$$(ms^2 + k) X(s) = 1 + A e^{-sT}$$

Solving for  $X(s)$ ,

$$\begin{aligned} X(s) &= \frac{1}{ms^2 + k} + \frac{Ae^{-sT}}{ms^2 + k} \\ &= \frac{1}{\sqrt{km}} \frac{\sqrt{\frac{k}{m}}}{s^2 + \frac{k}{m}} + \frac{A}{\sqrt{km}} \frac{\sqrt{\frac{k}{m}} e^{-sT}}{s^2 + \frac{k}{m}} \end{aligned}$$

The inverse Laplace transform of  $X(s)$  is

$$x(t) = \frac{1}{\sqrt{km}} \sin \sqrt{\frac{k}{m}} t + \frac{A}{\sqrt{km}} \left[ \sin \sqrt{\frac{k}{m}} (t-T) \right] \mathbf{1}(t-T)$$

If the motion of the mass  $m$  is to be stopped at  $t = T$ , then  $x(t)$  must be identically zero for  $t \geq T$ .

Notice that  $x(t)$  can be made identically zero for  $t \geq T$  if we choose

$$A = 1, \quad T = \frac{\pi}{\sqrt{\frac{k}{m}}}, \quad \frac{3\pi}{\sqrt{\frac{k}{m}}}, \quad \frac{5\pi}{\sqrt{\frac{k}{m}}}, \quad \dots$$

Thus, the motion of the mass  $m$  can be stopped by another impulse force, such as

$$\delta\left(t - \frac{\pi}{\sqrt{\frac{k}{m}}}\right), \quad \delta\left(t - \frac{3\pi}{\sqrt{\frac{k}{m}}}\right), \quad \delta\left(t - \frac{5\pi}{\sqrt{\frac{k}{m}}}\right), \quad \dots$$

B-5-6. For a unit-impulse input

$$c(t) = -te^{-t} + 2e^{-t} \quad (t \geq 0)$$

For a unit-step input

$$c(t) = 1 + te^{-t} - e^{-t} \quad (t \geq 0)$$

B-5-7.

$$\frac{Y(s)}{X(s)} = \frac{2(s-1)}{(s+2)(s+1)}$$

For a unit-step input, the response is given by

$$y(t) = -3e^{-2t} + 4e^{-t} - 1 \quad (t \geq 0)$$

A plot of  $y(t)$  versus  $t$  is shown below.

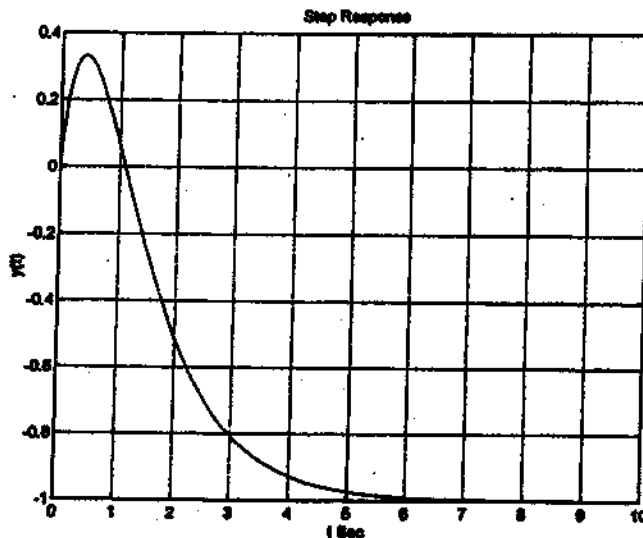

B-5-8.

$$\frac{x_1}{x_2} = \frac{e^{-5\omega_n t_1}}{e^{-5\omega_n(t_1+T)}} = \frac{1}{e^{-5\omega_n T}} = e^{5\omega_n T}$$

$$\frac{x_1}{x_n} = \frac{1}{e^{-5\omega_n(n-1)T}} = e^{(n-1)5\omega_n T}$$

$$\begin{aligned} \text{Logarithmic decrement} &= \ln \frac{x_1}{x_2} = \frac{1}{n-1} \ln \frac{x_1}{x_n} \\ &= 5\omega_n T = 5\omega_n \frac{2\pi}{\omega_d} = \frac{2\pi\zeta}{\sqrt{1-\zeta^2}} \end{aligned}$$

Define

$$\frac{1}{n-1} \ln \frac{x_1}{x_n} = \frac{2\pi\zeta}{\sqrt{1-\zeta^2}} = \Delta$$

Then

$$4\pi^2\zeta^2 = \Delta^2(1-\zeta^2)$$

or

$$\zeta^2 = \frac{\Delta^2}{4\pi^2 + \Delta^2}$$

Thus

$$\zeta = \frac{\Delta}{\sqrt{4\pi^2 + \Delta^2}} = \frac{\left(\frac{1}{n-1}\right)\left(\ln \frac{x_1}{x_n}\right)}{\sqrt{4\pi^2 + \left(\frac{1}{n-1}\right)^2 \left(\ln \frac{x_1}{x_n}\right)^2}}$$

**B-5-9.** For the system shown in Figure 4-54(b), we have

$$\frac{C(s)}{R(s)} = \frac{10}{s^2 + (1 + 10K_h)s + 10}$$

Noting that  $2\zeta\omega_n = 1 + 10K_h$ ,  $\omega_n^2 = 10$ ,  $\zeta = 0.5$ , we obtain

$$1 + 10K_h = 2 \times 0.5 \times \sqrt{10} = \sqrt{10}$$

Hence

$$K_h = \frac{\sqrt{10} - 1}{10} = 0.216$$

The unit-step response curves of both systems are shown below.

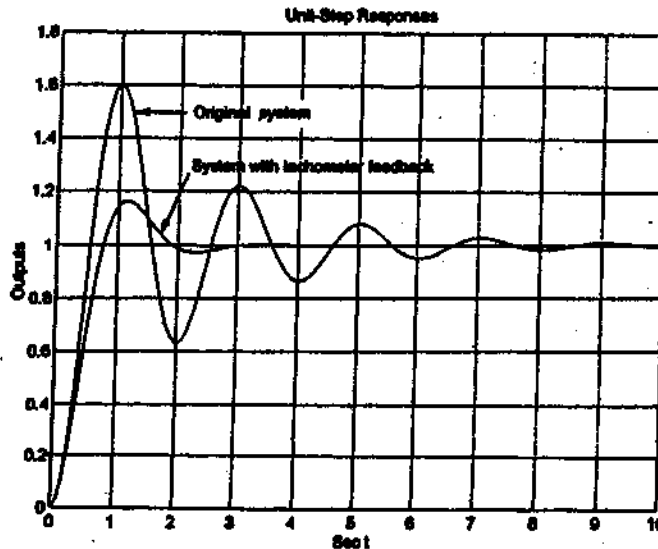

Note that for the original system

$$\frac{E_1(s)}{R(s)} = \frac{R(s) - C_1(s)}{R(s)} = \frac{s^2 + s}{s^2 + s + 10}$$

For the tachometer-feedback system

$$\frac{E_2(s)}{R(s)} = \frac{R(s) - C_2(s)}{R(s)} = \frac{s^2 + 3.16s}{s^2 + 3.16s + 10}$$

For the unit-ramp input, we have

$$E_1(s) = \left( \frac{s^2 + s}{s^2 + s + 10} \cdot \frac{1}{s} \right) \frac{1}{s} = \frac{s^2 + s}{s^3 + s^2 + 10s} \frac{1}{s}$$

$$E_2(s) = \left( \frac{s^2 + 3.16s}{s^2 + 3.16s + 10} \cdot \frac{1}{s} \right) \frac{1}{s} = \frac{s^2 + 3.16s}{s^3 + 3.16s^2 + 10s} \frac{1}{s}$$

The error versus time curves [ $e_1(t)$  versus  $t$  and  $e_2(t)$  versus  $t$ ] are shown below.

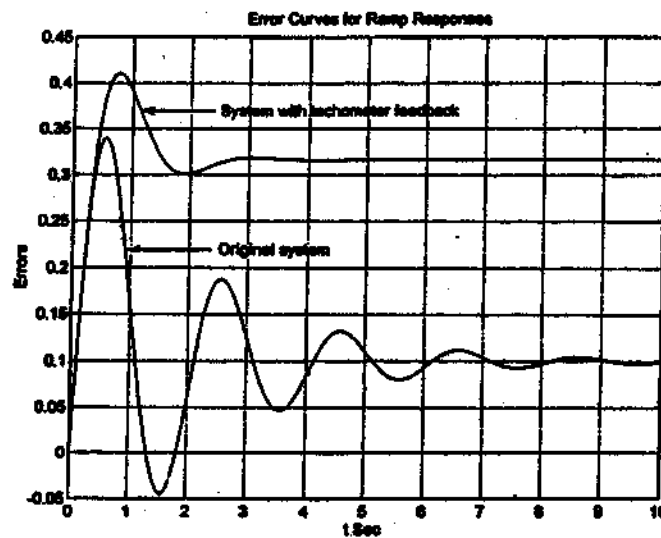

B-5-10. For the given system we have

$$\frac{C(s)}{R(s)} = \frac{K}{s^2 + 2s + Kk s + K}$$

Note that

$$K = \omega_n^2 = 4^2 = 16$$

Since

$$2.5\omega_n = 2 + Kk$$

we obtain

$$2 \times 0.7 \times 4 = 2 + Kk = 2 + 16k$$

Thus

$$k = 0.225$$

B-5-11.

$$\frac{C(s)}{R(s)} = \frac{16}{s^2 + (0.8 + 16k)s + 16}$$

From the characteristic polynomial, we find

$$\omega_n = 4, \quad 25\omega_n = 2 \times 0.5 \times 4 = 0.8 + 16k$$

Hence

$$k = 0.2$$

The rise time  $t_r$  is obtained from

$$t_r = \frac{\pi - \beta}{\omega_d}$$

Since

$$\omega_d = \omega_n \sqrt{1 - \zeta^2} = 4 \sqrt{1 - 0.25} = 3.46$$

$$\beta = \sin^{-1} \frac{\omega_d}{\omega_n} = \sin^{-1} 0.866 = \frac{\pi}{3}$$

we have

$$t_r = \frac{\pi - \frac{1}{3}\pi}{3.46} = 0.605 \text{ sec}$$

The peak time  $t_p$  is obtained as

$$t_p = \frac{\pi}{\omega_d} = \frac{3.14}{3.46} = 0.907 \text{ sec}$$

The maximum overshoot  $M_p$  is

$$M_p = e^{-\frac{\zeta\pi}{\sqrt{1-\zeta^2}}} = e^{-\frac{0.5 \times 3.14}{\sqrt{1-0.25}}} = e^{-1.817} = 0.163$$

The settling time  $t_s$  is

$$t_s = \frac{4}{5\omega_n} = \frac{4}{0.5 \times 4} = 2 \text{ sec}$$

---

B-5-12. A MATLAB program to obtain the unit-step response, unit-ramp response, and unit-impulse response of the given system is shown on the next page.

```

% ***** Unit-step response *****

num = [0 0 10];
den = [1 2 10];
t = 0:0.02:10;
step(num,den,t)
grid
title('Unit-Step Response')
xlabel('t Sec')
ylabel('c(t)')

% ***** Unit-ramp response *****

numr = [0 0 0 10];
denr = [1 2 10 0];
c = step(numr,denr,t);
plot(t,c,'-','t,t','--')
grid
title('Unit-Ramp Response')
xlabel('t Sec')
ylabel('c(t)')

% ***** Unit-impulse response *****

impulse(num,den,t)
grid
title('Unit-Impulse Response')
xlabel('t Sec')
ylabel('c(t)')

```

The unit-step response curve is shown below. The unit-ramp response curve and unit-impulse response curve are shown on the next page.

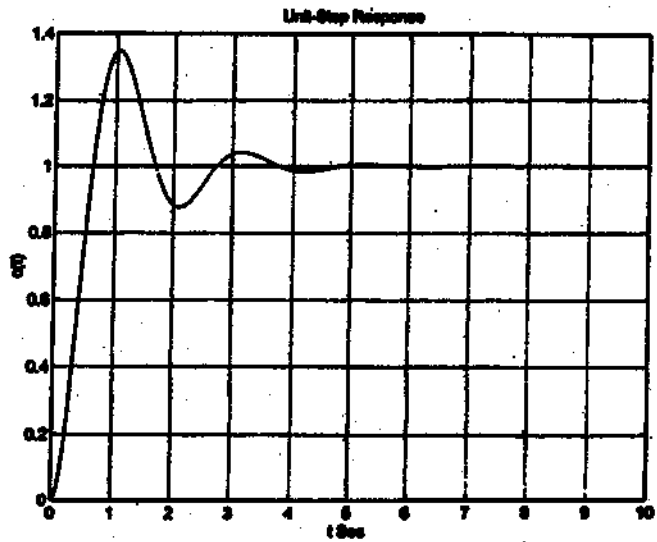

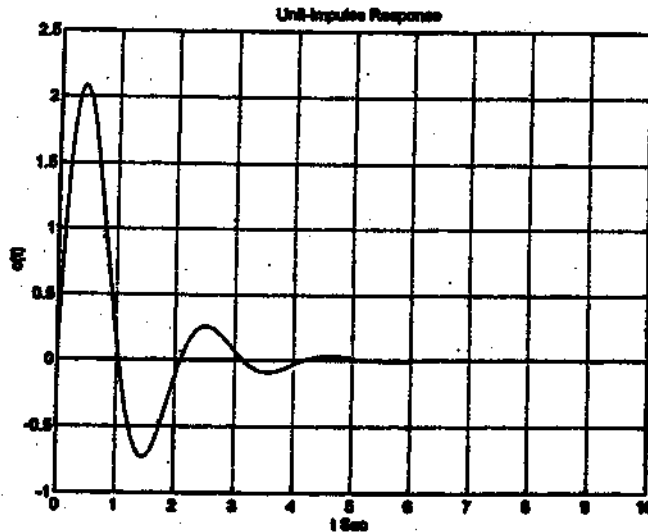
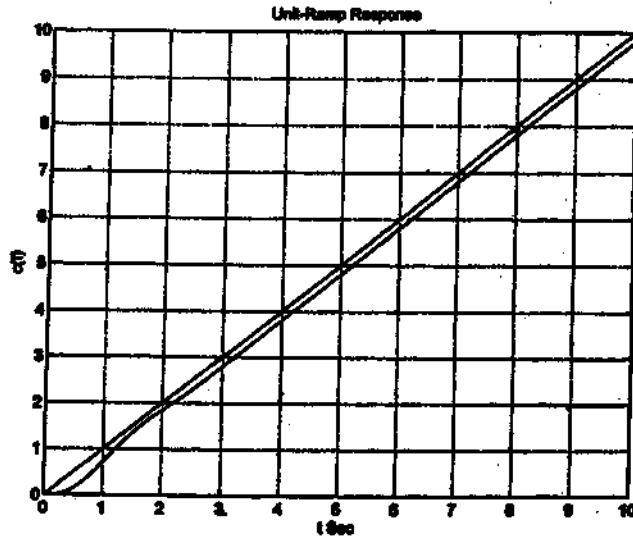

**B-5-13.** A MATLAB program to obtain a unit-step response of the given system is given below. The resulting unit-step response curve is shown on the next page.

```

% ***** Unit-Step Response *****
A = [-1 -0.5;1 0];
B = [0.5;0];
C = [1 0];
D = [0];
[y,x,t] = step(A,B,C,D);
plot(t,y)
grid
title('Unit-Step Response')
xlabel('t Sec')
ylabel('Output')

```

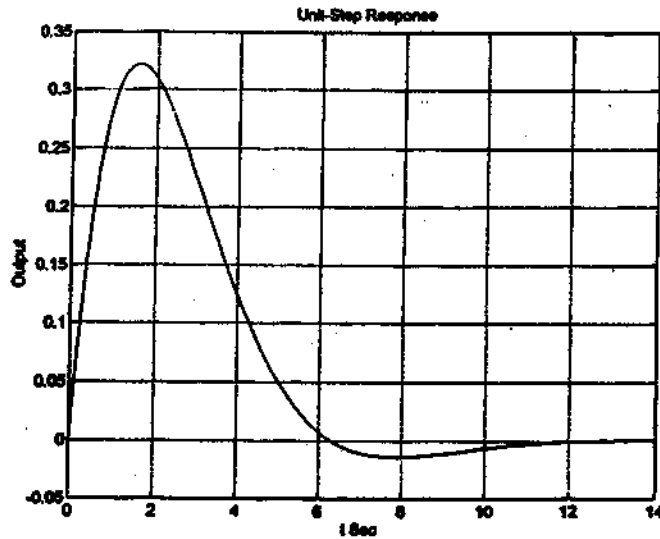

A MATLAB program to obtain a unit-ramp response of the given system is presented below, together with the unit-ramp response curve.

```

% ***** Unit-ramp response *****
A = [-1 -0.5;1 0];
B = [0.5;0];
C = [1 0];
D = [0];

% ***** Enter matrices AA, BB, CC, and DD of the new enlarged state
% equation and output equation *****

AA = [A zeros(2,1);C 0];
BB = [B;0];
CC = [0 0 1];
DD = [0];

% ***** Enter step-response command [z,x,t] = step(AA,BB,CC,DD) *****

[z,x,t] = step(AA,BB,CC,DD);
x3 = [0 0 1]*x'; plot(t,x3,t,t,'--')
grid
title('Unit-Ramp Response')
xlabel('t Sec')
ylabel('Output and Unit-Ramp Input')
text(1,3,'Output')

```

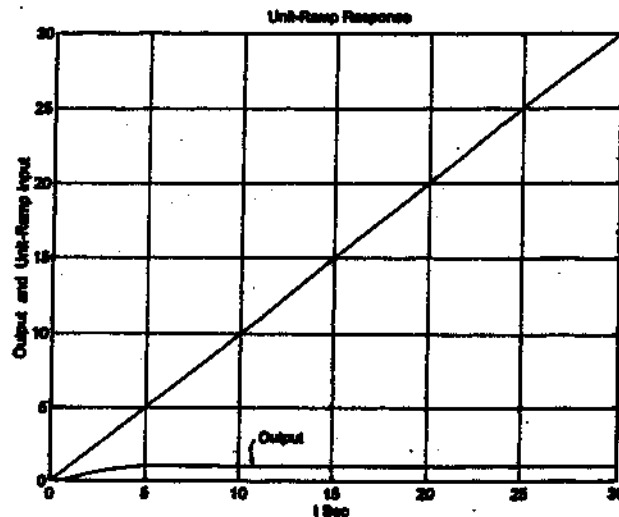

Finally, a MATLAB program to obtain a unit-impulse response of the system is given next, together with the unit-impulse response curve.

```

% ***** Unit-impulse response *****
A = [-1 -0.5; 1 0];
B = [0.5; 0];
C = [1 0];
D = [0];
impz(A,B,C,D)
    
```

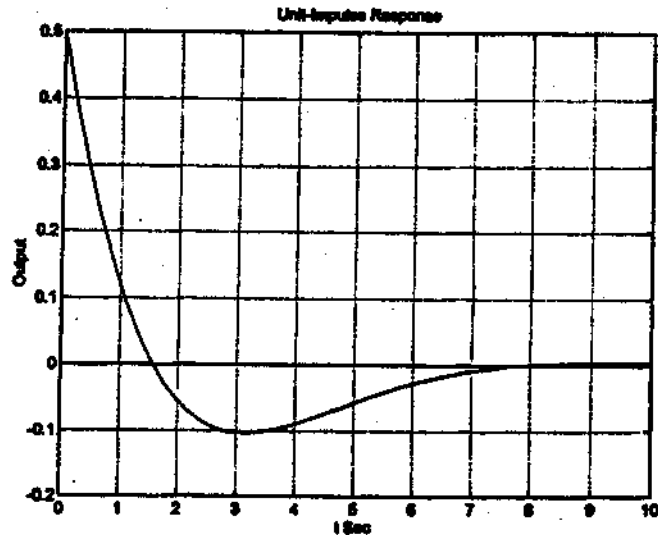

**B-5-14.** From the closed-loop transfer function

$$\frac{C(s)}{R(s)} = \frac{36}{s^2 + 2s + 36} = \frac{36}{(s+1)^2 + (\sqrt{35})^2}$$

we find that  $\omega_n = 6$ ,  $\zeta = \frac{1}{6}$ , and  $\omega_d = \sqrt{35}$ .

Rise time:

$$t_r = \frac{\pi - \beta}{\omega_d}$$

where

$$\begin{aligned} \beta &= \tan^{-1} \frac{\omega_d}{\zeta \omega_n} = \tan^{-1} \frac{\sqrt{1-5^2}}{5} = \tan^{-1} \frac{\sqrt{\frac{35}{36}}}{\frac{1}{6}} \\ &= \tan^{-1} 5.9161 = 1.4034 \text{ rad} \end{aligned}$$

Hence

$$t_r = \frac{3.1416 - 1.4034}{\sqrt{35}} = 0.2938 \text{ sec}$$

Peak time:

$$t_p = \frac{\pi}{\omega_d} = \frac{3.1416}{\sqrt{35}} = 0.5310 \text{ sec}$$

Maximum overshoot:

$$M_p = e^{-\frac{\zeta}{\sqrt{1-\zeta^2}} \pi} = e^{-\frac{\pi}{\sqrt{35}}} = e^{-0.5310} \\ = 0.5880$$

Settling time (2% criterion):

$$t_s = \frac{4}{\zeta \omega_n} = \frac{4}{\frac{1}{6} \times 6} = 4 \text{ sec}$$

A MATLAB program to obtain the rise time, peak time, maximum overshoot, and settling time is shown below. The unit-step response curve of this system is shown on the next page.

```
num = [0 0 36];
den = [1 2 36];
t = 0:0.001:5;
[y,x,t] = step(num,den,t);
r = 1; while y(r) < 1.0001; r = r+1; end
rise_time = (r-1)*0.001

rise_time =

    0.2940

[y_max,tp] = max(y);
peak_time = (tp-1)*0.001

peak_time =

    0.5310

max_overshoot = y_max-1

max_overshoot =

    0.5880

s = 5001; while y(s) > 0.98 & y(s) < 1.02; s = s-1; end;
settling_time = (s-1)*0.001

settling_time =

    3.8210
```

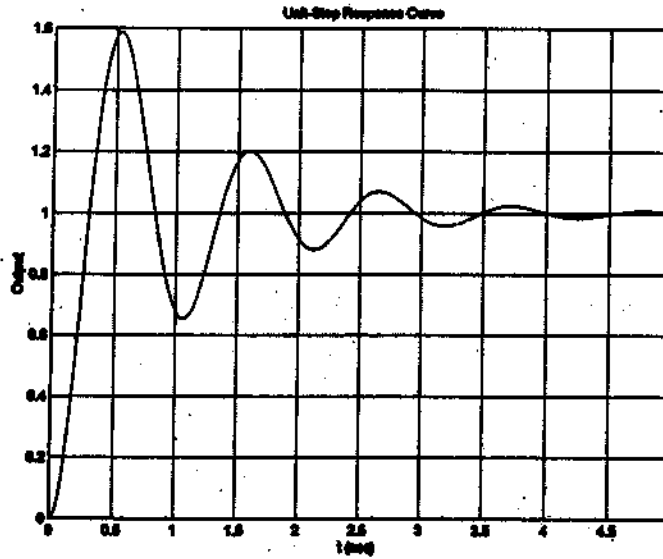

**B-5-15.** The closed-loop transfer function of System I is

$$\frac{C_I(s)}{R(s)} = \frac{1}{s^2 + 0.25s + 1}$$

The closed-loop transfer function of System II is

$$\frac{C_{II}(s)}{R(s)} = \frac{1 + 0.8s}{s^2 + s + 1}$$

The closed-loop transfer function of System III is

$$\frac{C_{III}(s)}{R(s)} = \frac{1}{s^2 + s + 1}$$

The unit-step response curves for the three systems are shown in Figure 1. The system utilizing proportional-plus-derivative control action exhibits the shortest rise time. The system with velocity feedback has the least maximum overshoot, or the best relative stability, of the three systems.

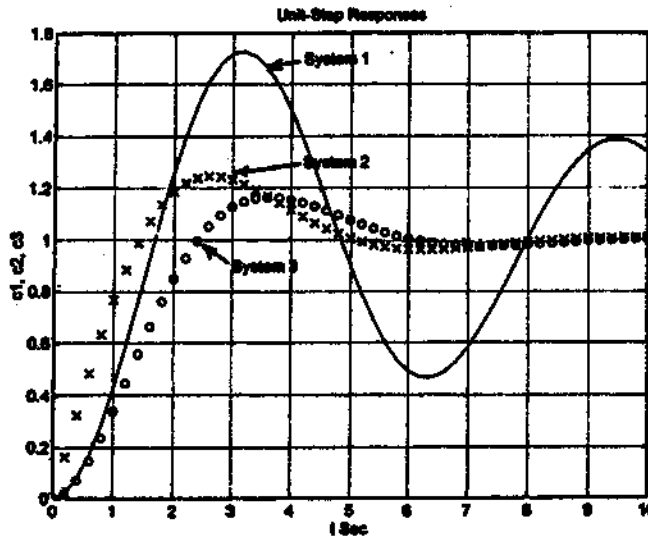

Figure 1

The unit-impulse response curves for the three systems are shown in Figure 2.

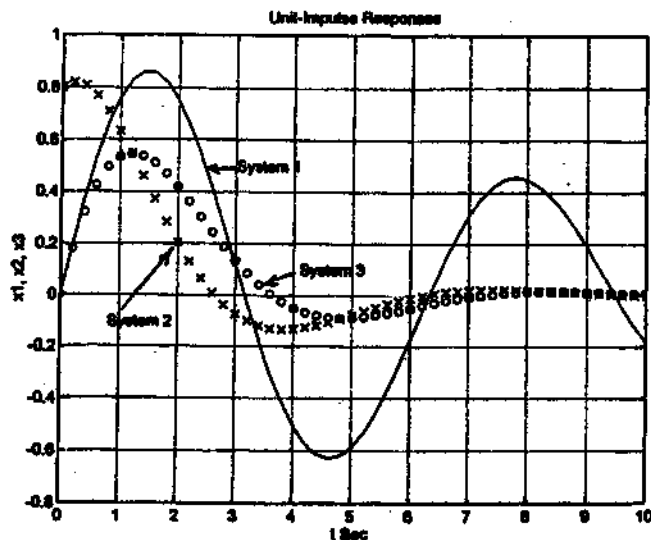

Figure 2

The unit-ramp response curves for the three systems are shown in Figure 3. System II has the advantage of quicker response and less steady error in following a ramp input.

The main reason why the System II that utilizes proportional-plus-derivative control action has superior response characteristics is that derivative control responds to the rate of change of the error signal and can produce early corrective action before the magnitude of the error becomes large. Notice that the output of System III is the output of System II delayed by a first-order lag term  $1/(1 + 0.8s)$ .

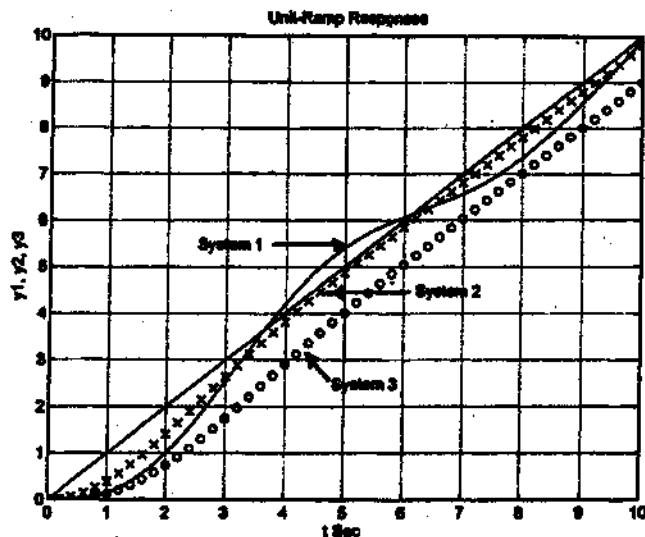

Figure 3

The MATLAB program that used to obtain Figures 1, 2, and 3 is shown below.

```
% ---- Obtaining unit-step, unit-impulse, and unit-ramp responses ----  
  
% ***** Unit-step responses of three systems *****  
  
num1 = [0 0 1];  
den1 = [1 0.2 1];  
num2 = [0 0.8 1];  
den2 = [1 1 1];  
num3 = [0 0 1];  
den3 = [1 1 1];  
c1 = step(num1,den1,t);  
c2 = step(num2,den2,t);  
c3 = step(num3,den3,t);  
plot(t,c1,'-',t,c2,'x', t,c3,'o')  
grid  
title('Unit-Step Responses')  
xlabel('t Sec')  
ylabel('c1, c2, c3')  
text(4.2,1.7,'System 1')  
text(4.2,1.3,'System 2')  
text(3,0.9,'System 3')  
  
% ***** Unit-impulse responses of three systems *****  
  
x1 = impulse(num1,den1,t);  
x2 = impulse(num2,den2,t);  
x3 = impulse(num3,den3,t);  
  
plot(t,x1,'-',t,x2,'x', t,x3,'o')  
grid  
title('Unit-Impulse Responses')  
xlabel('t Sec')  
ylabel('x1, x2, x3')  
text(3,0.5,'System 1')  
text(0.8,-0.1,'System 2')  
text(4.1,0.1,'System 3')  
  
% ***** Unit-ramp responses of three systems *****  
  
num1r = [0 0 0 1];  
den1r = [1 0.2 1 0];  
num2r = [0 0 0.8 1];  
den2r = [1 1 1 0];  
num3r = [0 0 0 1];  
den3r = [1 1 1 0];  
y1 = step(num1r,den1r,t);  
y2 = step(num2r,den2r,t);  
y3 = step(num3r,den3r,t);  
plot(t,t,'-',t,y1,'-',t,y2,'x', t,y3,'o')  
grid  
title('Unit-Ramp Responses')  
xlabel('t Sec')  
ylabel('y1, y2, y3')  
text(2.5,5.5,'System 1')  
text(6.2,4.5,'System 2')  
text(4.8,2.5,'System 3')
```

**B-5-16.** The closed-loop transfer function of the system is

$$\frac{X_1(s)}{R(s)} = \frac{40}{0.1s^3 + s^2 + 10s + 40}$$

MATLAB program to obtain the unit-step response curve is given below, together with the unit-step response curve.

```
% ***** Unit-step response *****
num = [0 0 0 40];
den = [0.1 1 10 40];
t = 0:0.01:2;
x1 = step(num,den,t);
plot(t,x1,'-')
grid
title('Unit-Step Response')
xlabel('t Sec')
ylabel('x1')
```

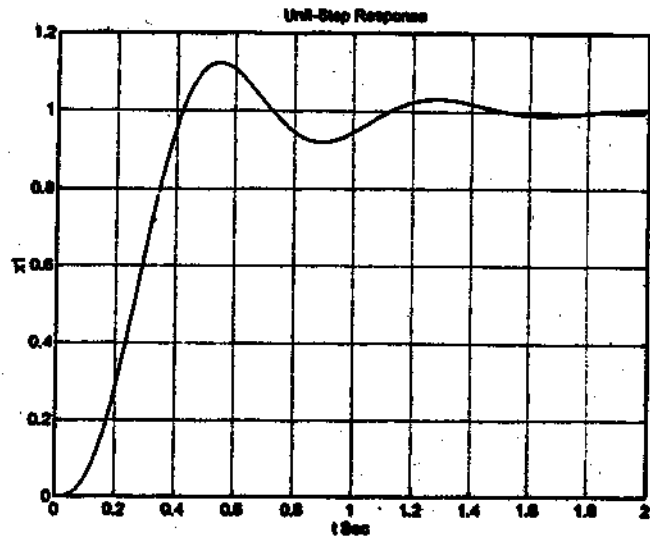

A MATLAB program to obtain the unit-ramp response curve is given below. The resulting unit-ramp response curve is also shown.

```
% ***** Unit-ramp response *****
numr = [0 0 0 0 40];
denr = [0.1 1 10 40 0];
t = 0:0.01:2;
y1 = step(numr,denr,t);
plot(t,t,'-',t,y1,'-')
grid
title('Unit-Ramp Response')
xlabel('t Sec')
ylabel('Ramp Input and Output x1')
```

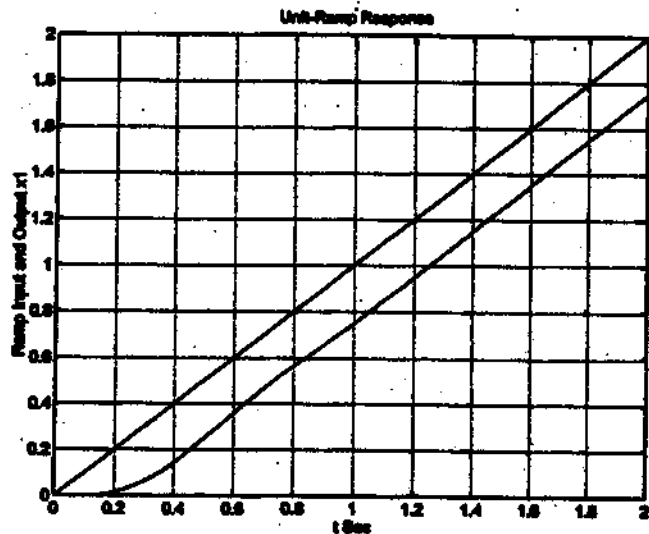

Noting that  $x_2 = \frac{d}{dt} x_1$ , we have

$$\frac{X_2(s)}{R(s)} = \frac{40s}{0.1s^3 + s^2 + 10s + 40}$$

The response  $x_2(t)$  for the unit-step input and that for the unit-ramp input can be obtained by using the MATLAB program given on the next page. The resulting response curves [ $x_2(t)$  versus  $t$  curves] are also shown on the next page.

```
% ***** MATLAB program to obtain responses x2 to inputs r(t) = 1(t) and
% r(t) = t.1(t) *****
```

```
num2 = [0 0 40 0];
den2 = [0.1 1 10 40];
t = 0:0.02:3;
x2 = step(num2,den2,t);
plot(t,x2)
grid
title('Response x2 to input r(t) = 1(t)')
xlabel('t Sec')
ylabel('x2')
```

```
num2r = [0 0 0 40 0];
den2r = [0.1 1 10 40 0];
y2 = step(num2r,den2r,t);
plot(t,t,'-',t,y2,'o');
grid
title('Response x2 to input r(t) = t.1(t)')
xlabel('t Sec')
ylabel('Input Unit-Ramp and Response x2')
```

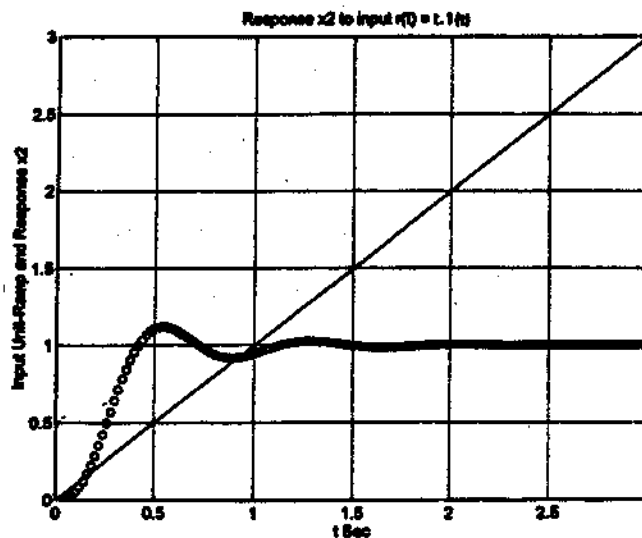
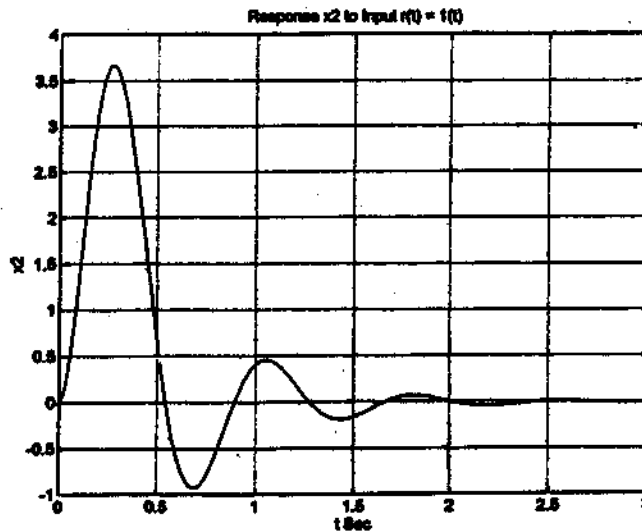

Next, we shall obtain  $x_3(t)$  versus  $t$  curves for the unit-step input and unit-ramp input. Noting that

$$\frac{X_2(s)}{X_3(s)} = \frac{10}{0.1s + 1}$$

and

$$\frac{X_2(s)}{R(s)} = \frac{40s}{0.1s^3 + s^2 + 10s + 40}$$

we have

$$\frac{X_3(s)}{R(s)} = \frac{X_3(s)}{X_2(s)} \cdot \frac{X_2(s)}{R(s)} = \frac{4s^2 + 40s}{s^3 + 10s^2 + 100s + 400}$$

The following MATLAB program can be used to obtain responses  $x_3(t)$  to inputs  $r(t) = 1(t)$  and  $r(t) = t \cdot 1(t)$ . The response curves are shown below and on the next page.

```
% ***** MATLAB program to obtain response x3 to inputs
% r(t) = 1(t) and r(t) = t.1(t) *****

num3 = [0 4 40 0];
den3 = [1 10 100 400];
t = 0:0.01:3;
x3 = step(num3,den3,t);
plot(t,x3);
grid
title('Response x3 to input r(t) = 1(t)')
xlabel('t Sec')
ylabel('x3')

num3r = [0 0 4 40 0];
den3r = [1 10 100 400 0];
y3 = step(num3r,den3r,t);
plot(t,t,'-',t,y3,'o')
grid
title('Response x3 to Input r(t) = t.1(t)')
xlabel('t Sec')
ylabel('Input Unit Ramp and x3')
```

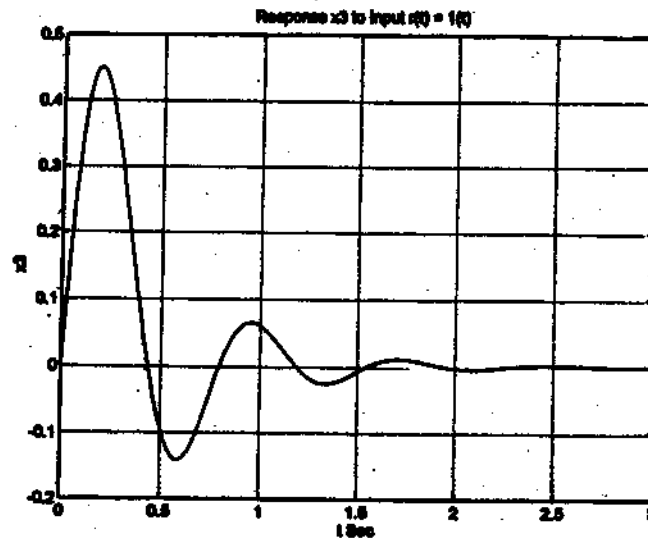

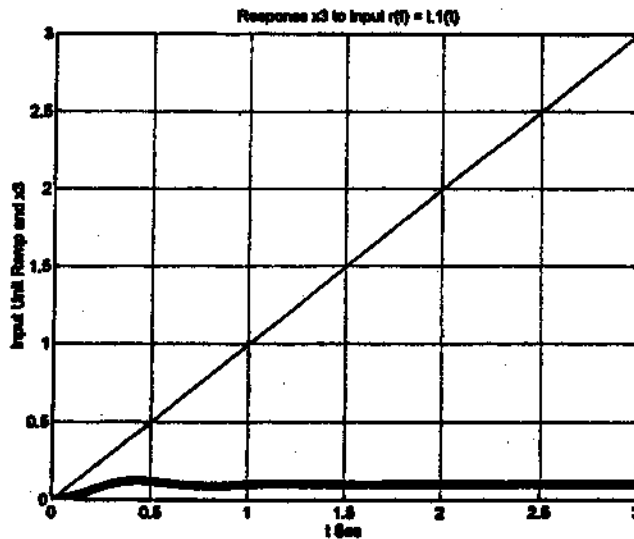

Finally, we shall obtain the error versus  $t$  curves. Plots of  $e(t)$  versus  $t$  curves when the input  $r(t)$  is a unit step or unit ramp can be obtained by use of the following MATLAB program.

```
% --- MATLAB program to obtain e(t) versus t curves ---
% ***** Unit-step response *****
num = [0 0 0 40];
den = [0.1 1 10 40];
t = 0:0.01:3;
x1 = step(num,den,t);
plot(t, 1 - x1);
grid
title('Plot of e(t) versus t when r(t) = 1(t)')
xlabel('t Sec')
ylabel('e(t) = 1(t) - x1(t)')

% ***** Unit-ramp response *****

numr = [0 0 0 0 40];
denr = [0.1 1 10 40 0];
y1 = step(numr,denr,t);
plot(t,t,'--',t,t - y1,'o')
grid
title('Plot of e(t) versus t when r(t) = t.1(t)')
xlabel('t Sec')
ylabel('e(t) = t.1(t) - x1(t)')
```

The error  $e(t)$  versus  $t$  curves are shown on the next page.

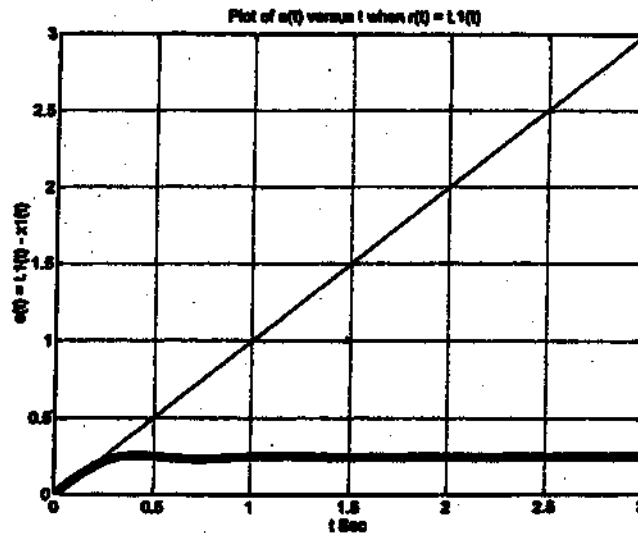
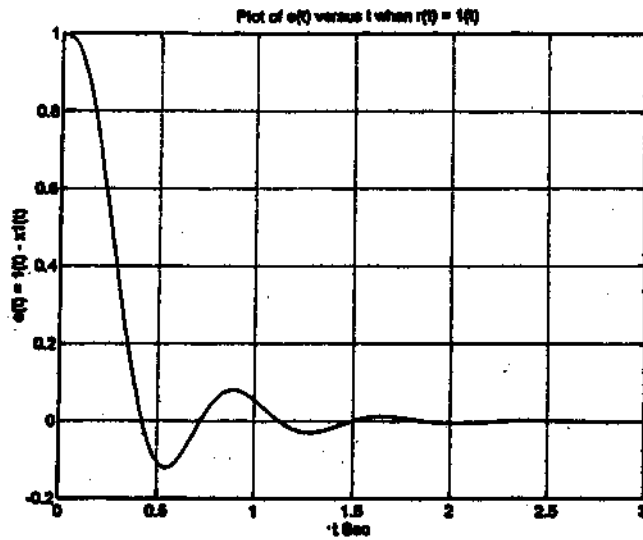

**B-5-17.** The closed-loop transfer function  $C(s)/R(s)$  of this system is

$$\begin{aligned} \frac{C(s)}{R(s)} &= \frac{G(s)}{1 + G(s)} = \frac{\frac{10}{s(s+2)(s+4)}}{1 + \frac{10}{s(s+2)(s+4)}} \\ &= \frac{10}{s^3 + 6s^2 + 8s + 10} \end{aligned}$$

A MATLAB program to obtain the unit-step response curve as well as the rise time, peak time, maximum overshoot, and settling time is shown on the next page. The unit-step response curve is also shown on the next page.

```

num = [0 0 0 10];
den = [1 6 8 10];
t = 0:0.002:10;
[y,x,t] = step(num,den,t);
plot(t,y)
grid
title('Unit-Step Response Curve')
xlabel('t (sec)')
ylabel('Output')

r = 1; while y(r) < 1.0001; r = r+1; end
rise_time = (r-1)*0.002

rise_time =

    1.7720

[y_max,tp] = max(y);
peak_time = (tp-1)*0.002

peak_time =

    2.6320

max_overshoot = y_max-1

max_overshoot =

    0.2146

s = 5001; while y(s) > 0.98 & y(s) < 1.02; s = s-1; end;
settling_time = (s-1)*0.002

settling_time =

    5.9960

```

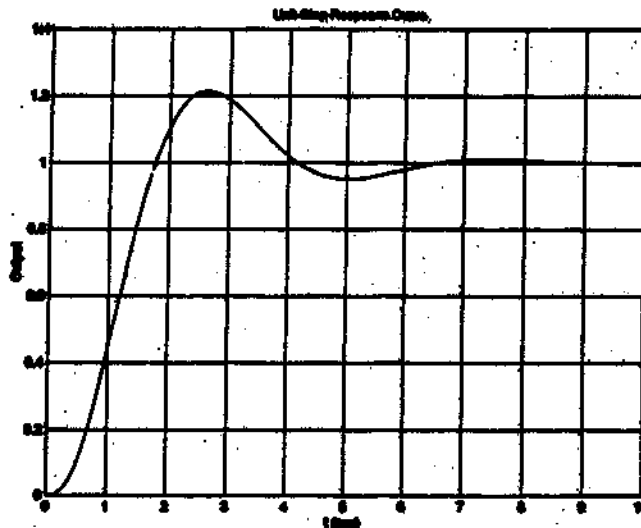

**B-5-18.** A MATLAB program that produces a two-dimensional diagram of unit-impulse response curves and a three-dimensional plot of the response curves is given below.

```

% To plot a Two-Dimensional Diagram.

t = 0:0.2:10;
zeta = [0.2 0.4 0.6 0.8 1];
for n = 1:5;
    num = [0 2*zeta(n) 1];
    den = [1 2*zeta(n) 1];
    [y(1:51,n),x,t] = impulse(num,den,t);
end
plot(t,y)
grid
title('Plot of Unit-Impulse Response Curves with \zeta = 0.2,0.4,0.6,0.8,1')
xlabel('t (sec)')
ylabel('Response')
text(2.5,0.4,'0.2')
text(2.5,0.6,'0.4')
text(2.5,0.8,'0.6')
text(0.5,1.3,'0.8')
text(0.5,1.75,'1')

% To plot a Three-Dimensional Diagram.

mesh(t,zeta,y)
title('Three-Dimensional Plot of Unit-Impulse Response Curves')
xlabel('t (sec)')
ylabel('\zeta')
zlabel('Response')

```

The two-dimensional diagram and three-dimensional diagram produced by this MATLAB program are shown below and on the next page, respectively.

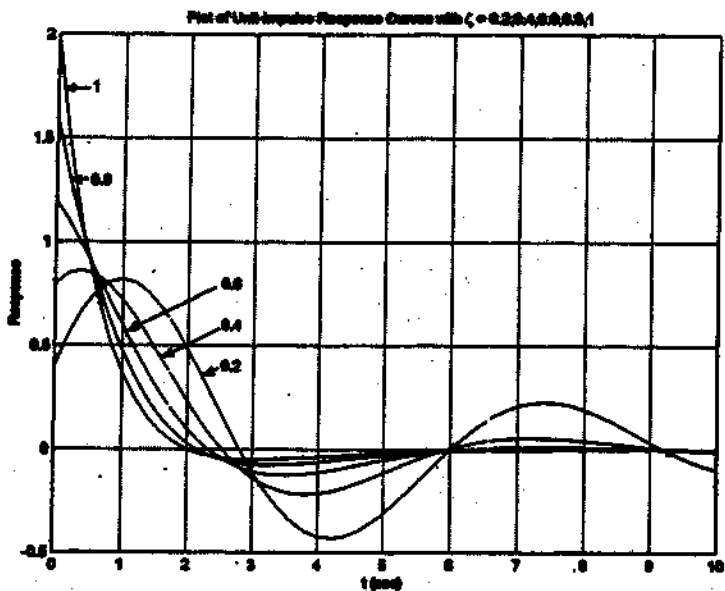

Three-Dimensional Plot of Unit-Step Response Curves

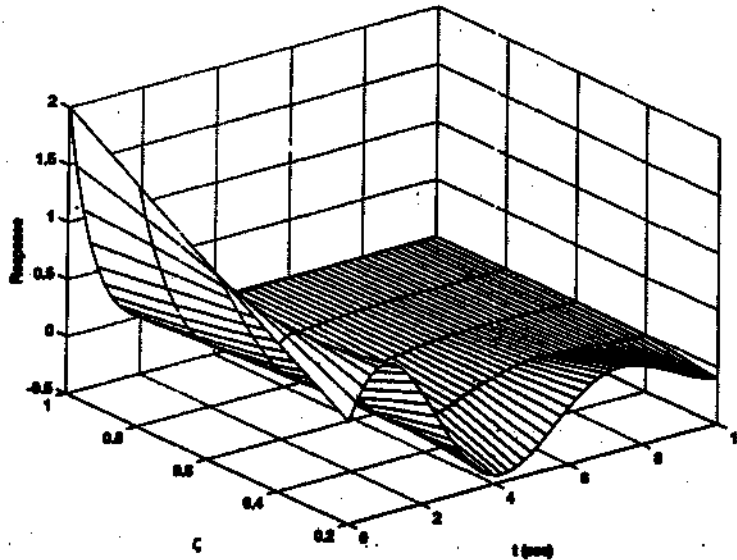

**B-5-19.** A MATLAB program to produce a three-dimensional diagram of the unit-step response curves is shown below. The resulting three-dimensional plot is also shown below.

```

t = 0:0.2:10;
zeta = [0.2 0.4 0.6 0.8 1];
for n = 1:5;
    num = [0 1 1];
    den = [1 2*zeta(n) 1];
    [y(1:51,n),x,t] = step(num,den,t);
end
mesh(t,zeta,y)
title('Three-Dimensional Plot of Unit-Step Response Curves')
xlabel('t (sec)')
ylabel('zeta')
zlabel('Response')
    
```

Three-Dimensional Plot of Unit-Step Response Curves

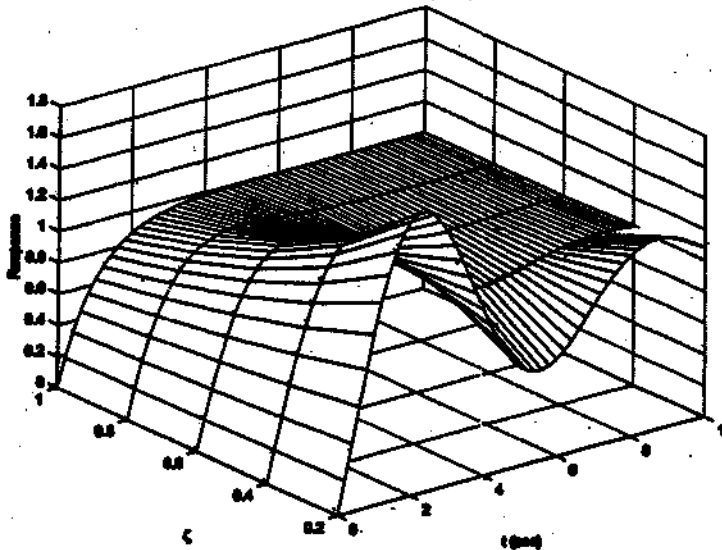

**B-5-20.** A MATLAB program to obtain the unit-ramp response curve of the given system is given below.

```

% MATLAB Program for Problem B-5-20
A = [0 1; -1 -1];
B = [0; 1];
C = [1 0];
D = 0;
t = 0:0.1:8;
u = t;
y = lsim(A,B,C,D,u,t);
plot(t,u,'-',t,y,'o')
grid
title('Unit-Ramp Response')
xlabel('t (sec)')
ylabel('Unit-Ramp Input and System Output')
text(1.5,4.5,'Unit-Ramp Input')
text(4.5,2.5,'Output')

```

The resulting response curve is shown below, together with the unit-ramp input.

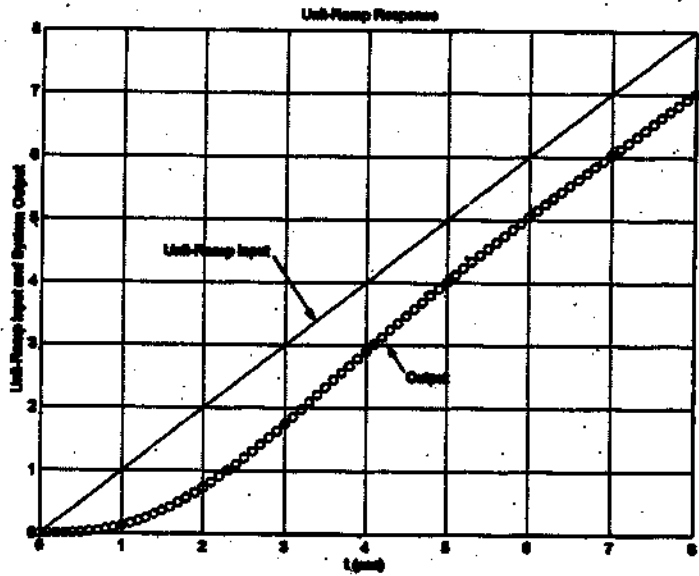

**B-5-21.** The closed-loop transfer function of the system is

$$\frac{C(s)}{R(s)} = \frac{G(s)}{1 + G(s)} = \frac{10s + 10}{s^3 + 4s^2 + 10s + 10}$$

The unit-acceleration input is given by

$$r(t) = 0.5 t^2 \quad (t \geq 0)$$

A MATLAB program to obtain the response of the system subjected to the unit-acceleration input is given on the next page.

```
% MATLAB Program to solve Problem B-5-21
```

```
num = [0 0 10 10];
den = [1 4 10 10];
t = 0:0.1:5;
r = 0.5*t.^2;
y = lsim(num,den,r,t);
plot(t,r,'-',t,y,'o')
grid
title('System Response to Unit-Acceleration Input')
xlabel('t (sec)')
ylabel('Unit-Acceleration Input and System Output')
text(0.7,4.5,'Unit-Acceleration Input')
text(3.3,3,'Output')
```

The response curve is shown in the figure below, together with the unit-acceleration input.

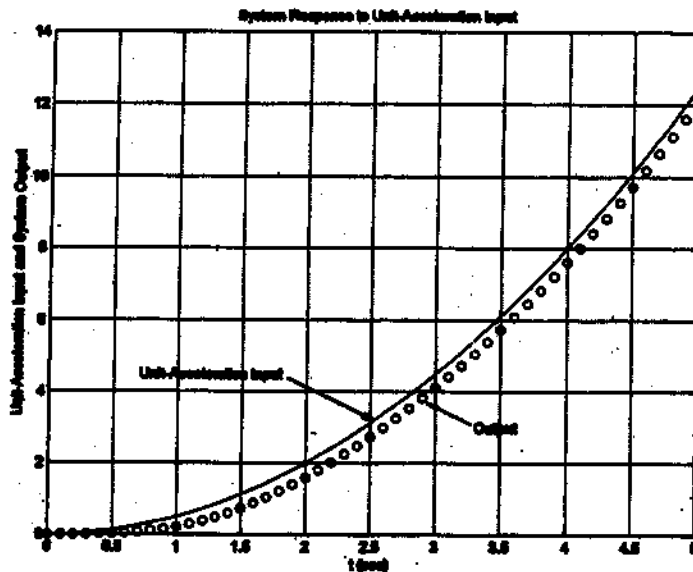

**B-5-22.** By taking the Laplace transform of the differential equation:

$$\ddot{y} + 3\dot{y} + 2y = 0, \quad y(0) = 0.1, \quad \dot{y}(0) = 0.05$$

we obtain

$$s^2Y(s) - sy(0) - \dot{y}(0) + 3[sY(s) - y(0)] + 2Y(s) = 0$$

By substituting the given initial condition, we get

$$(s^2 + 3s + 2)Y(s) = 0.1s + 0.35$$

Solving this last equation for  $Y(s)$ , we obtain

$$Y(s) = \frac{0.1s + 0.35}{s^2 + 3s + 2} = \frac{0.1s + 0.35}{(s+1)(s+2)} = \frac{0.25}{s+1} - \frac{0.15}{s+2}$$

The inverse Laplace transform of  $Y(s)$  gives

$$y(t) = 0.25e^{-t} - 0.15e^{-2t}$$

This is the solution of the given differential equation.

MATLAB solution:

Let us obtain a state space equation for the system. Define

$$x_1 = y$$

$$x_2 = \dot{y}$$

Then, the state space equation and the output equation become as follows:

$$\begin{bmatrix} \dot{x}_1 \\ \dot{x}_2 \end{bmatrix} = \begin{bmatrix} 0 & 1 \\ -2 & -3 \end{bmatrix} \begin{bmatrix} x_1 \\ x_2 \end{bmatrix}, \quad \begin{bmatrix} x_1(0) \\ x_2(0) \end{bmatrix} = \begin{bmatrix} 0.1 \\ 0.05 \end{bmatrix}$$

$$y = [1 \quad 0] \begin{bmatrix} x_1 \\ x_2 \end{bmatrix}$$

A possible MATLAB program to obtain the response  $y(t)$  is given in the following. The resulting response curve is shown below.

```
A = [0 1; -2 -3];
B = [0; 0];
C = [1 0];
D = 0;
t = 0:0.01:5;
y = initial(A,B,C,D,[0.1;0.05],t);
plot(t,y)
grid
title('Response to Initial Condition')
xlabel('t (sec)')
ylabel('Output y')
```

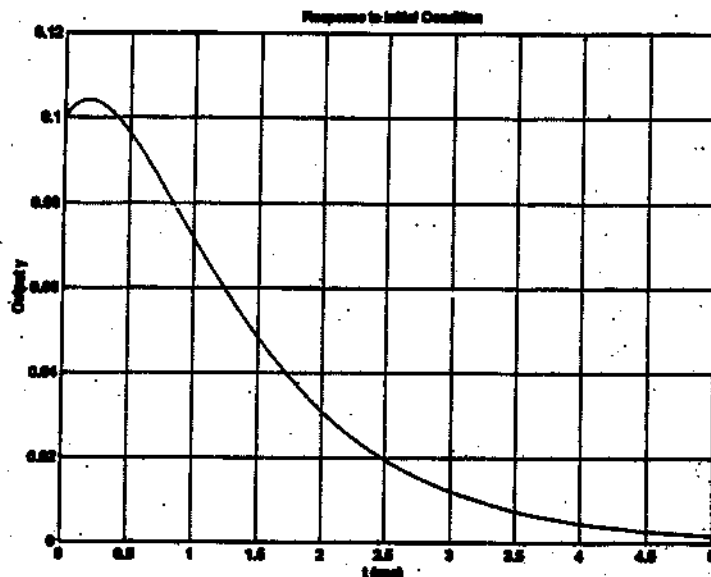

B-5-23.

$$\frac{C(s)}{R(s)} = \frac{K}{s(s+1)(s+2) + K}$$

The characteristic equation is

$$s^3 + 3s^2 + 2s + K = 0$$

The Routh array becomes

$$\begin{array}{ccc} s^3 & 1 & 2 \\ s^2 & 3 & K \\ s^1 & \frac{6-K}{3} & \\ s^0 & K & \end{array}$$

For stability we require  $6 > K$  and  $K > 0$ , or

$$6 > K > 0$$

---

B-5-24.

$$\frac{C(s)}{R(s)} = \frac{10}{s(s-1)(2s+3) + 10}$$

The characteristic equation is

$$2s^3 + s^2 - 3s + 10 = 0$$

The Routh array becomes

$$\begin{array}{ccc} s^3 & 2 & -3 \\ s^2 & 1 & 10 \\ s^1 & -23 & \\ s^0 & 10 & \end{array}$$

The system is unstable.

---

B-5-25. For the characteristic equation

$$s^4 + 2s^3 + (4+K)s^2 + 9s + 25 = 0$$

the Routh array of coefficients is

$$\begin{array}{r}
s^4 \quad 1 \quad 4+K \quad 25 \\
s^3 \quad 2 \quad 9 \quad 0 \\
s^2 \quad \frac{2K-1}{2} \quad 25 \\
s^1 \quad \frac{18K-109}{2K-1} \quad 0 \\
s^0 \quad 25
\end{array}$$

For stability, we require

$$\frac{2K-1}{2} > 0, \quad \frac{18K-109}{2K-1} > 0$$

or

$$K > 0.5, \quad 18K > 109$$

Hence

$$K > \frac{109}{18} = 6.056$$

For stability, K must be greater than 109/18.

B-5-26. The closed-loop transfer function  $C(s)/R(s)$  is

$$\begin{aligned}
\frac{C(s)}{R(s)} &= \frac{K(s-2)}{(s+1)(s^2+6s+25) + K(s-2)} \\
&= \frac{K(s-2)}{s^3 + 7s^2 + (31+K)s + 25 - 2K}
\end{aligned}$$

For stability, the denominator of this last equation must be a stable polynomial. For the characteristic equation

$$s^3 + 7s^2 + (31+K)s + 25 - 2K = 0$$

the Routh array becomes as follows:

$$\begin{array}{r}
s^3 \quad 1 \quad 31+K \\
s^2 \quad 7 \quad 25-2K \\
s^1 \quad \frac{192+9K}{7} \quad 0 \\
s^0 \quad 25-2K
\end{array}$$

Since K is assumed to be positive, for stability, we require

$$12.5 > K > 0$$

**B-5-27.** From Figure 5-89(b) we have

$$\frac{C(s)}{R(s)} = \frac{K}{Js^2 + KK_h s + K} = \frac{\frac{K}{J}}{s^2 + \frac{KK_h}{J}s + \frac{K}{J}}$$

By substituting  $K/J = 4$  into this last equation, we obtain

$$\frac{C(s)}{R(s)} = \frac{4}{s^2 + 4K_h s + 4}$$

Since  $\omega_n = 2$ ,  $\zeta = 0.6$ , and  $2\zeta\omega_n = 4K_h$ , we have

$$K_h = \frac{2\zeta\omega_n}{4} = 0.6$$

**B-5-28.** From the block diagram of Figure 5-90, we have

$$\frac{C(s)}{R(s)} = \frac{20K}{s^3 + 5s^2 + (4 + 20KK_h)s + 20K}$$

The stability of this system is determined by the denominator polynomial (characteristic polynomial). The Routh array of the characteristic equation

$$s^3 + 5s^2 + (4 + 20KK_h)s + 20K = 0$$

is

$$\begin{array}{r} s^3 \quad 1 \quad 4 + 20KK_h \\ s^2 \quad 5 \quad 20K \\ s^1 \quad 4 + 20KK_h - 4K \quad 0 \\ s^0 \quad 20K \end{array}$$

For stability, we require

$$4 + 20KK_h - 4K > 0, \quad 20K > 0$$

or

$$5KK_h > K - 1, \quad K > 0$$

The stable region in the  $K$ - $K_h$  plane is the region that satisfies these two inequalities. Figure 1 shows the stable region in the  $K$ - $K_h$  plane. If a point in the  $K$ - $K_h$  plane (that is, a combination of  $K$  and  $K_h$  values) lies in the shaded region, then the system is stable. Conversely, if a point in the  $K$ - $K_h$  plane lies in the nonshaded region, the system is unstable. The dividing curve is defined by  $5KK_h = K - 1$ . (Any point above this dividing curve corresponds to a stable combination of  $K$  and  $K_h$ .)

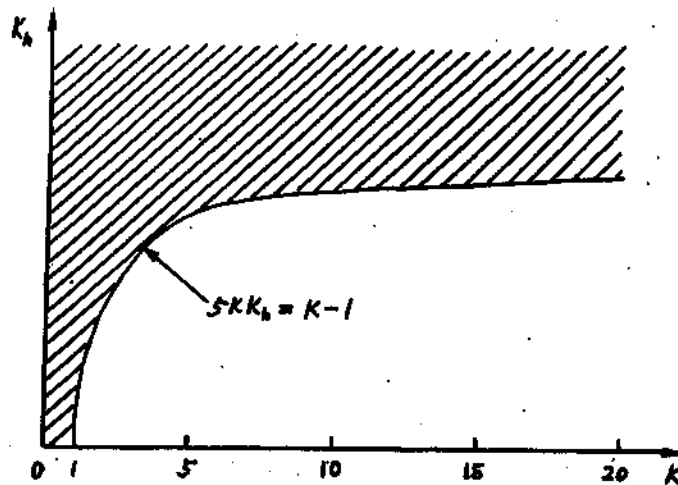

Figure 1

B-5-29.

$$|sI - A| = \begin{vmatrix} s & -1 & 0 \\ b_3 & s & -1 \\ 0 & b_2 & s+b_1 \end{vmatrix}$$

$$= s^3 + b_1 s^2 + (b_2 + b_3) s + b_1 b_3$$

The Routh array is

$$\begin{array}{l} s^3 \quad 1 \quad b_2 + b_3 \\ s^2 \quad b_1 \quad b_1 b_3 \\ s^1 \quad b_2 \quad 0 \\ s^0 \quad b_1 b_3 \end{array}$$

Thus, the first column of the Routh array of the characteristic equation consists of 1,  $b_1$ ,  $b_2$ , and  $b_1 b_3$ .

B-5-30.

$$\frac{C(s)}{R(s)} = \frac{G(s)}{1+G(s)} = \frac{Ks+b}{s^2+as+b}$$

Hence

$$(s^2 + as + b) G(s) = (Ks + b) [1 + G(s)]$$

or

$$G(s) = \frac{Ks+b}{s(s+a-K)}$$

The steady-state error in the unit-ramp response is

$$e_{ss} = \frac{1}{K_v} = \lim_{s \rightarrow 0} \frac{1}{sG(s)} = \lim_{s \rightarrow 0} \frac{s(s+a-k)}{s(Ks+b)} = \frac{a-k}{b}$$

B-5-31. The closed-loop transfer function is

$$= \frac{K}{Js^2 + Bs + K}$$

For a unit-ramp input,  $R(s) = 1/s^2$ . Thus,

$$\frac{E(s)}{R(s)} = \frac{R(s) - C(s)}{R(s)} = \frac{Js^2 + Bs}{Js^2 + Bs + K}$$

or

$$E(s) = \frac{Js^2 + Bs}{Js^2 + Bs + K} \frac{1}{s^2}$$

The steady-state error is

$$e_{ss} = e(\infty) = \lim_{s \rightarrow 0} sE(s) = \frac{B}{K}$$

We see that we can reduce the steady-state error  $e_{ss}$  by increasing the gain  $K$  or decreasing the viscous-friction coefficient  $B$ . Increasing the gain or decreasing the viscous-friction coefficient, however, causes the damping ratio to decrease, with the result that the transient response of the system will become more oscillatory. Doubling  $K$  decreases  $e_{ss}$  to half of its original value, while  $\zeta$  is decreased to 0.707 of its original value since  $\zeta$  is inversely proportional to the square root of  $K$ . On the other hand, decreasing  $B$  to half of its original value decreases both  $e_{ss}$  and  $\zeta$  to the halves of their original values, respectively. Therefore, it is advisable to increase the value of  $K$  rather than to decrease the value of  $B$ . After the transient response has died out and a steady state is reached, the output velocity becomes the same as the input velocity. However, there is a steady-state positional error between the input and the output. Examples of the unit-ramp response of the system for three different values of  $K$  are illustrated to the right.

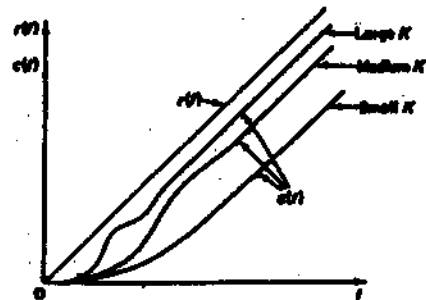

B-5-32. Consider the system shown below.

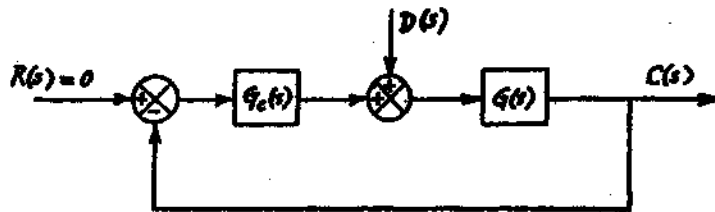

From the diagram we obtain

$$\frac{C(s)}{D(s)} = \frac{G(s)}{1 + G(s)G_c(s)}$$

For a ramp disturbance  $d(t) = at$ , we have  $D(s) = a/s^2$ . Hence,

$$c(\infty) = \lim_{s \rightarrow 0} s C(s) = \lim_{s \rightarrow 0} \frac{s G(s)}{1 + G(s)G_c(s)} \frac{a}{s^2} = \lim_{s \rightarrow 0} \frac{a}{s G_c(s)}$$

$c(\infty)$  becomes zero if  $G_c(s)$  contains double integrators.

---

# CHAPTER 6

**B-6-1.** The open-loop transfer function for the system is

$$G(s)H(s) = \frac{K(s+1)}{s^2}$$

We first locate the open-loop poles and zero on the complex plane. A root locus exists on the negative real axis between  $-1$  and  $-\infty$ . Since the open-loop transfer function involves two poles and one zero, there is a possibility that a circular root loci exists.

The equation for the root-locus branches can be obtained from the angle condition

$$\angle \frac{K(s+1)}{s^2} = \pm 180^\circ (2k+1)$$

which can be rewritten as

$$\angle s+1 - 2 \angle s = \pm 180^\circ (2k+1)$$

By substituting  $s = \sigma + j\omega$ , we obtain

$$\angle \sigma + j\omega + 1 - 2 \angle \sigma + j\omega = \pm 180^\circ (2k+1)$$

or

$$\tan^{-1} \left( \frac{\omega}{\sigma+1} \right) - 2 \tan^{-1} \frac{\omega}{\sigma} = \pm 180^\circ (2k+1)$$

Rearranging, we obtain

$$\tan^{-1} \left( \frac{\omega}{\sigma+1} \right) - \tan^{-1} \frac{\omega}{\sigma} = \tan^{-1} \frac{\omega}{\sigma} \pm 180^\circ (2k+1)$$

Taking the tangents of both sides of this last equation,

$$\tan \left[ \tan^{-1} \left( \frac{\omega}{\sigma+1} \right) - \tan^{-1} \left( \frac{\omega}{\sigma} \right) \right] = \tan \left[ \tan^{-1} \frac{\omega}{\sigma} \pm 180^\circ (2k+1) \right]$$

which can be simplified to

$$\frac{\frac{\omega}{\sigma+1} - \frac{\omega}{\sigma}}{1 + \frac{\omega}{\sigma+1} \frac{\omega}{\sigma}} = \frac{\frac{\omega}{\sigma} \pm 0}{1 + \frac{\omega}{\sigma} \times 0} = \frac{\omega}{\sigma}$$

Hence

$$\frac{\omega}{\sigma+1} - \frac{\omega}{\sigma} = \frac{\omega}{\sigma} \left( 1 + \frac{\omega}{\sigma+1} \frac{\omega}{\sigma} \right)$$

from which we obtain

$$\omega [(\sigma+1)^2 + \omega^2 - 1] = 0$$

This last equation is equivalent to

$$\omega = 0 \quad \text{or} \quad (0+1)^2 + \omega^2 = 1$$

These two equations are the equations for the root loci for the system. The first equation,  $\omega = 0$ , is the equation for the real axis. The real axis from  $s = -1$  to  $s = -\infty$  corresponds to a root locus for  $K \geq 0$ . (The remaining part of the real axis corresponds to a root locus for  $K < 0$ .) In the present system,  $K$  is positive. The second equation is an equation of a circle with the center at  $\sigma = -1$ ,  $\omega = 0$  and the radius equal to 1. The root-locus diagram is shown below.

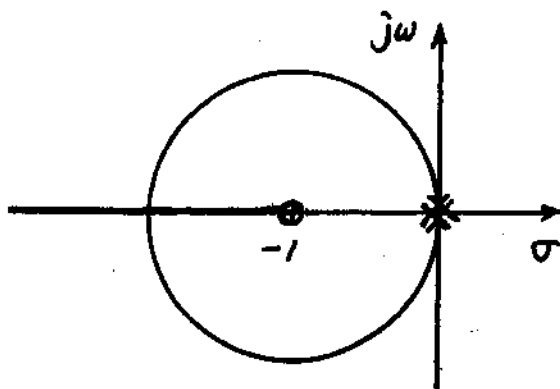

**B-6-2.** The open-loop transfer function is

$$G(s)H(s) = \frac{K(s+4)}{(s+1)^2}$$

This system is similar to the one in Problem B-6-1. The system involves two poles and one zero. The root-locus plot involves a circular root locus. A root-locus plot of the system is shown below.

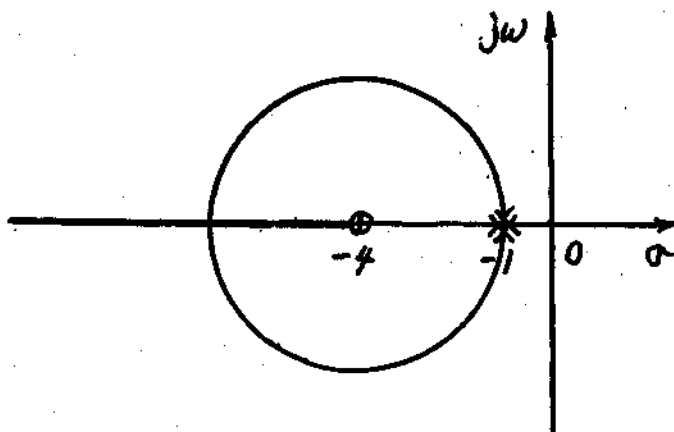

B-6-3. The open-loop transfer function

$$G(s)H(s) = \frac{K}{s(s+1)(s^2+4s+5)}$$

has the poles at  $s = 0$ ,  $s = -1$ ,  $s = -2 \pm j1$  and no zeros. The asymptotes have angles  $\pm 45^\circ$  and  $\pm 135^\circ$ . The asymptotes meet on the negative real axis at  $\sigma_A = -1.25$ . Two branches of the root loci cross the imaginary axis at  $s = \pm j1$ . The angle of departure from the complex pole in the upper half  $s$  plane is  $+162^\circ$ .

A MATLAB program to plot the root loci and asymptotes is given below, together with the resulting root-locus plot.

```

% ***** Root-locus plot *****
num = [0 0 0 0 1];
den = [1 5 9 5 0];
numa = [0 0 0 0 1];
dena = [1 5 9.375 7.8125 2.4414];
r = rlocus(num,den);
plot(r,'-')
hold
Current plot held
plot(r,'o')
rlocus(numa,dena)
v = [-4 2 -3 3]; axis(v); axis('square');
grid
title('Plot of Root Loci and Asymptotes')

```

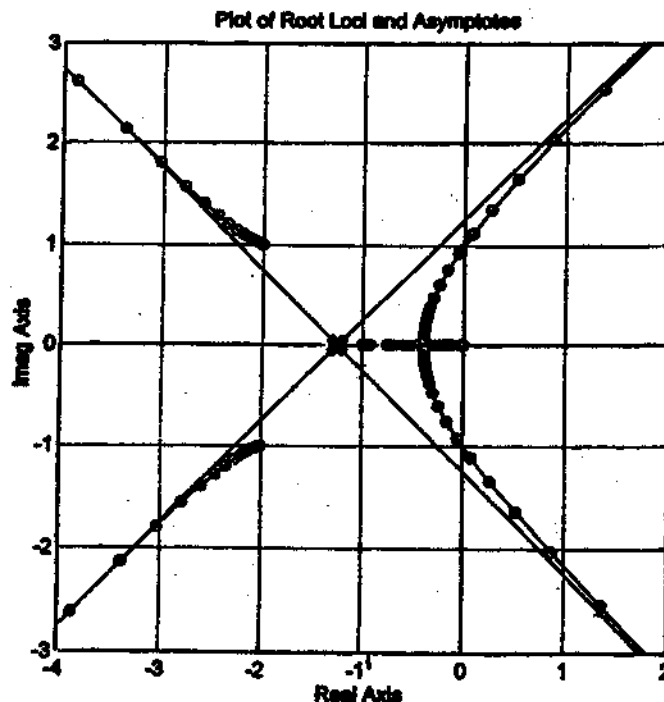

B-6-4. A MATLAB program to plot the root loci and asymptotes for the following system:

$$G(s)H(s) = \frac{K}{s(s+0.5)(s^2+0.65s+10)}$$

is given below and the resulting root-locus plot is shown below.  
 Note that the equation for the asymptotes is

$$G_a(s)H_a(s) = \frac{K}{(s+0.275)^4}$$

$$= \frac{K}{s^4 + 1.1s^3 + 0.45375s^2 + 0.0831874s + 0.0057191}$$

```

% ***** Root-locus plot *****
num = [0 0 0 0 1];
den = [1 1.1 10.3 5 0];
numa = [0 0 0 0 1];
dena = [1 1.1 0.45375 0.0831874 0.0057191];
r = rlocus(num,den);
plot(r,'-')
hold
Current plot held
plot(r,'o')
rlocus(numa,dena)

v = [-5 5 -5 5]; axis(v); axis('square');
grid
title('Plot of Root Loci and Asymptotes (Problem B-6-4)')
    
```

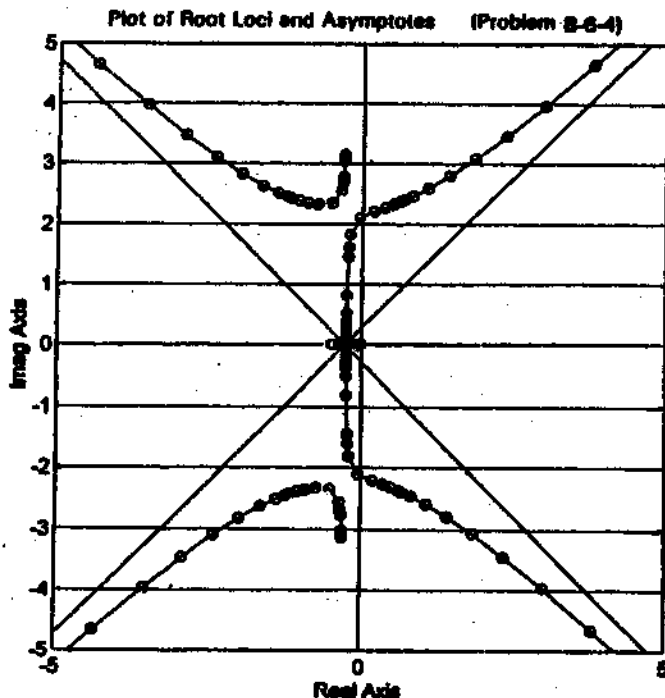

**B-6-5.** A MATLAB program to plot the root loci and asymptotes for the system

$$G(s)H(s) = \frac{K}{(s^2 + 2s + 2)(s^2 + 2s + 5)}$$

is shown below. The resulting root-locus plot is also shown below. The root loci cross the imaginary axis at  $\omega = \pm 1.87$ . This point is obtained by solving the following equation:

$$\begin{aligned} & [(j\omega)^2 + 2j\omega + 2][(j\omega)^2 + 2j\omega + 5] + K \\ &= (\omega^4 - 9\omega^2 + 10 + K) + j(-4\omega^3 + 14\omega) = 0 \end{aligned}$$

By equating the imaginary part equal to zero, we obtain  $\omega = \pm 1.8708$ . By equating the real part equal to zero, we get the gain value at the crossing point to be 9.25.

```
% ***** Root-locus plot *****
num = [0 0 0 0 1];
den = [1 4 11 14 10];
numa = [0 0 0 0 1];
dena = [1 4 6 4 1];
r = rlocus(num,den);
plot(r,'-')
hold
Current plot held
plot(r,'o')
rlocus(numa,dena)
v = [-6 4 -5 5]; axis(v); axis('square');
grid
title('Plot of Root Loci and Asymptotes (Problem B-6-5)')
```

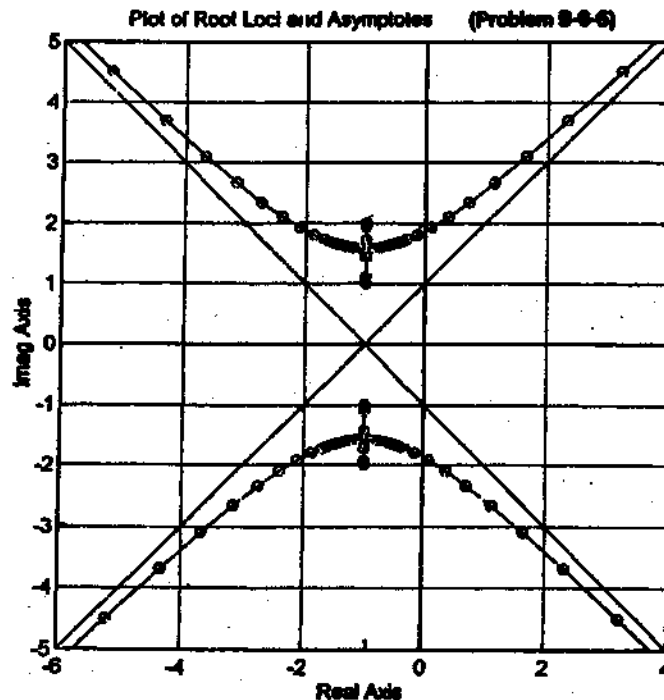

**B-6-6.**

$$1 + G(s)H(s) = \frac{(1+K)s^2 + (2+6K)s + 10 + 10K}{s^2 + 2s + 10}$$

The characteristic equation

$$(1+K)s^2 + (2+6K)s + 10 + 10K = 0$$

has two roots at

$$s = -\frac{1+3K}{1+K} \pm j \frac{\sqrt{K^2 + 14K + 9}}{1+K}$$

If we write  $s = X \pm jY$ , that is

$$X = -\frac{1+3K}{1+K}, \quad Y = \frac{\sqrt{K^2 + 14K + 9}}{1+K}$$

then

$$X^2 + Y^2 = \left(\frac{1+3K}{1+K}\right)^2 + \frac{K^2 + 14K + 9}{(1+K)^2} = \frac{10(K+1)^2}{(1+K)^2} = 10$$

This indicates that the root loci are on a circle about the origin of radius  $\sqrt{10}$ .

**B-6-7.** The open-loop transfer function

$$G(s)H(s) = \frac{K(s+0.2)}{s^2(s+3.6)}$$

has the zero at  $s = -0.2$  and the double poles at  $s = 0$  and a single pole at  $s = -3.6$ . The asymptotes have angles of  $\pm 90^\circ$ . The asymptotes meet on the real axis at  $\sigma_a = -1.7$ . The breakaway or break-in points are located at  $s = 0$ ,  $s = -0.43155$ , and  $s = -1.6685$ . A MATLAB program to obtain the root locus plot is shown below. The resulting root-locus plot is shown on the next page.

```
% ***** Root-locus plot *****
num = [0 0 1 0.2];
den = [1 3.6 0 0];
rlocus(num,den)
v = [-6 2 -4 4]; axis(v); axis('square')
grid
title('Root-Locus Plot (Problem B-6-7)')
```

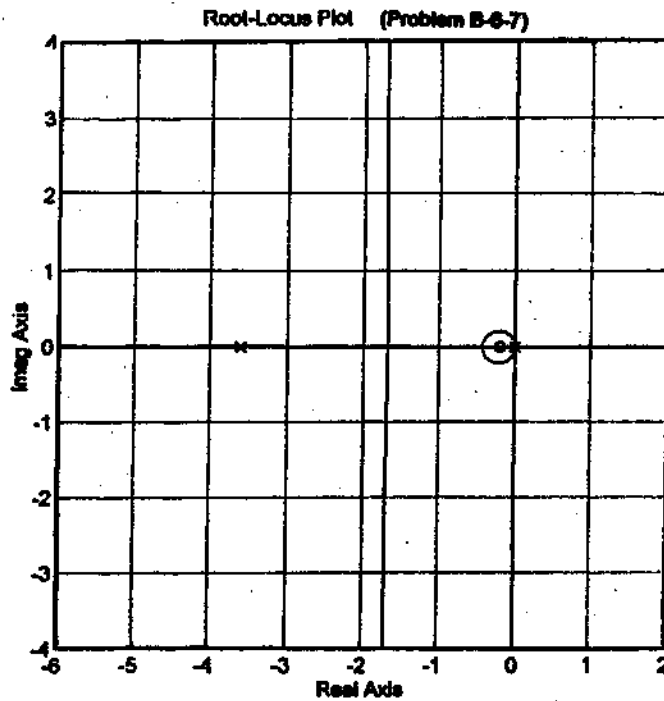

**B-6-8.** The open-loop transfer function

$$G(s)H(s) = \frac{K(s+0.5)}{s^3 + s^2 + 1}$$

has the poles at  $s = 0.2328 \pm j 0.7926$  and  $s = -1.4656$ . The zero is at  $s = -0.5$ . A MATLAB program to plot the root loci is shown below. The resulting root-locus plot is shown on the next page.

```

% ***** Root-locus plot *****
num = [0 0 1 0.5];
den = [1 1 0 1];
rlocus(num,den)
v = [-3 3 -3 3]; axis(v); axis('square')
grid
title('Root-Locus Plot (Problem B-6-8)')
```

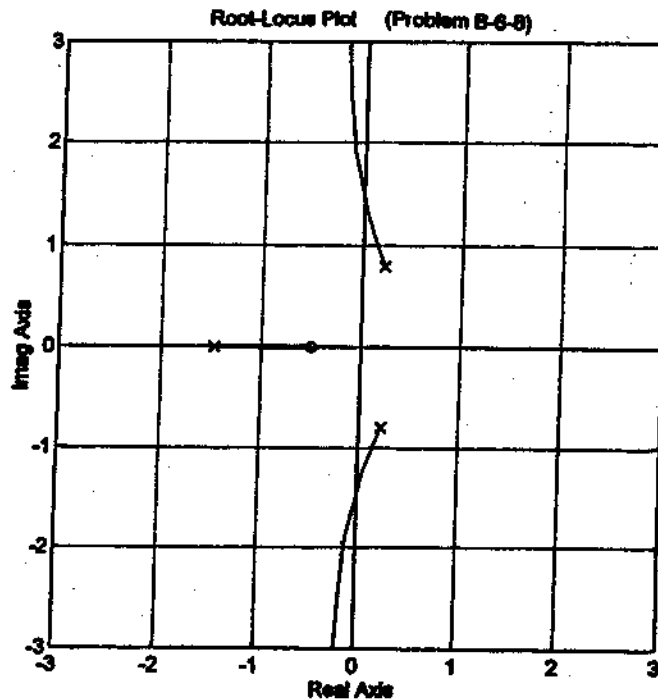

**B-6-9.** The open-loop transfer function

$$G(s)H(s) = \frac{K(s+9)}{s(s^2 + 4s + 11)}$$

has the poles at  $s = 0$ ,  $s = -2 \pm j\sqrt{7}$  and the zero at  $s = -9$ . The asymptotes have angles  $+90^\circ$  and meet the real axis at  $\sigma_a = 2.5$ . The complex branches cross the imaginary axis at  $s = \pm j 4.45$ . The angle of departure from the complex pole in the upper half  $s$  plane is  $-16.5^\circ$ .

The dominant closed-loop poles having the damping ratio  $\zeta = 0.5$  can be located as the intersection of the root loci and lines from the origin having angles  $\pm 60^\circ$ . The desired dominant closed-loop poles are found to be at

$$s = -1.5 \pm j 2.598$$

The third pole is at  $s = -1$ . The gain value corresponding to these dominant closed-loop poles is  $K = 1$ . A MATLAB program to plot the root-loci is shown below. The resulting root-locus plot is shown on the next page.

```
% ***** Root-locus plot *****
num = [0 0 1 9];
den = [1 4 11 0];
rlocus(num,den)
hold
Current plot held
x = [0,-3]; y = [0,5.196]; line(x,y);
v = [-15 5 -10 10]; axis(v); axis('square')
grid
title('Root-Locus Plot of G(s)H(s) = K(s+9)/[s(s^2+4s+11)')
```

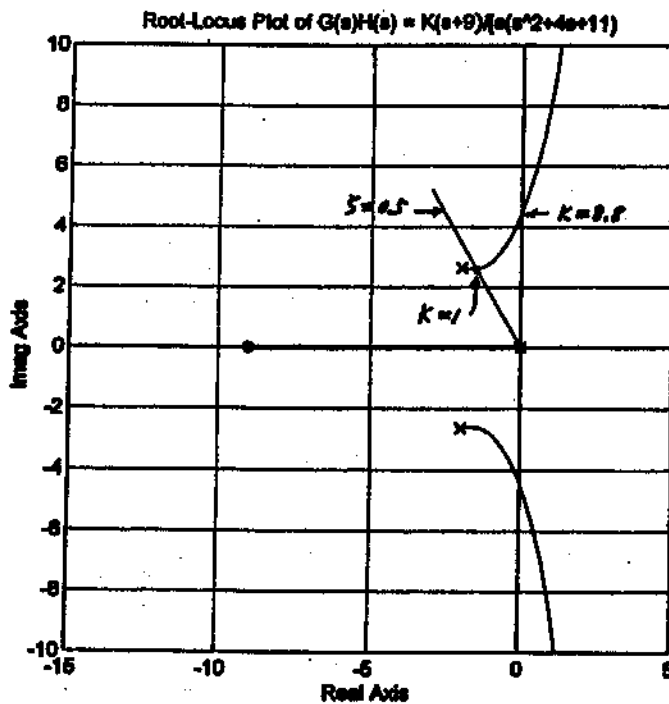

**B-6-10.** A MATLAB program to obtain a root-locus plot of the given system is shown below. The resulting root-locus plot is shown on the next page.

```

% ***** Root-locus plot *****
num = [0 0 0 2 2];
den = [1 7 10 0 0];
numa = [0 0 0 1];
dena = [0.5 3 6 4];
r = rlocus(num,den);
plot(r,'-')
hold
Current plot held
plot(r,'o')
rlocus(numa,dena)
v = [-10 10 -10 10]; axis(v); axis('square');
grid
title('Plot of Root Loci and Asymptotes (Problem B-6-10)')

```

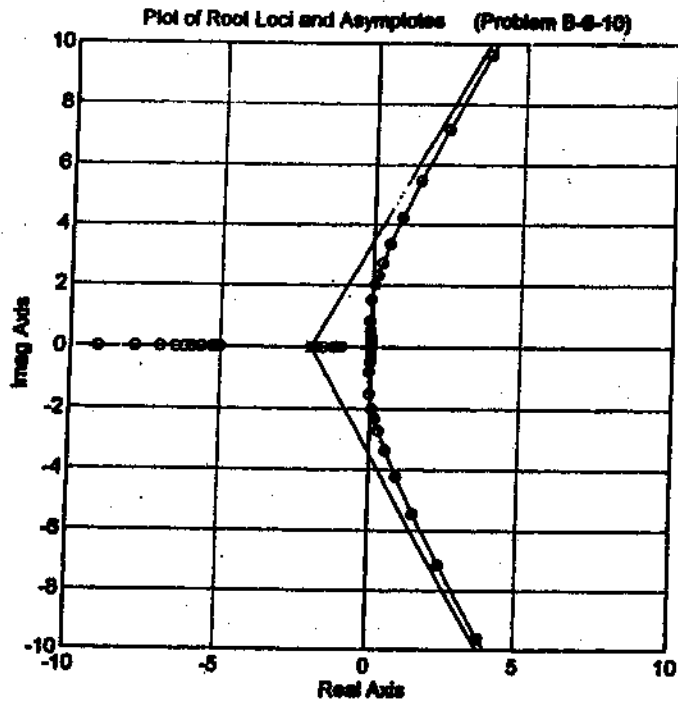

A root-locus plot near the origin can be obtained by entering the following MATLAB program into the computer. The resulting root-locus plot near the origin is shown next.

```

% ***** Root-locus plot *****
num = [0 0 0 2 2];
den = [1 7 10 0 0];
rlocus(num,den)
v = [-3 3 -3 3]; axis(v); axis('square');
grid
title('Root-Locus Plot near the Origin (Problem B-6-10)')

```

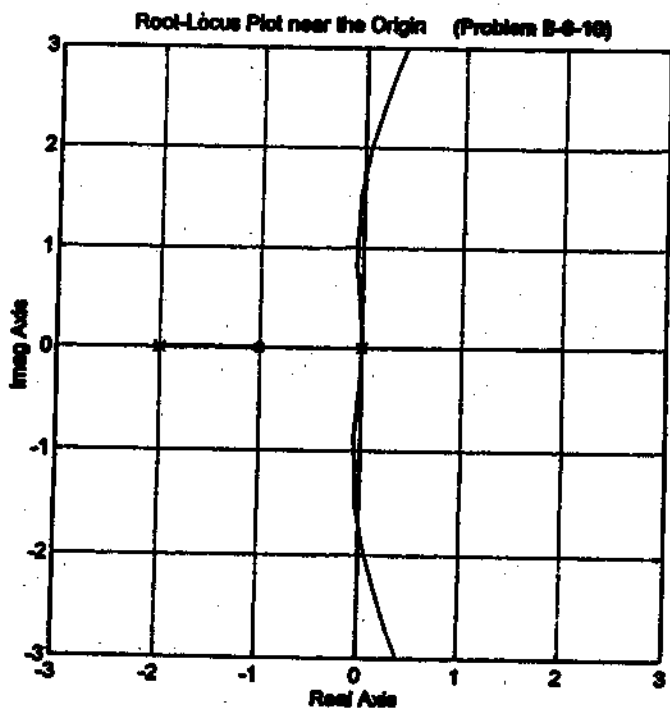

The range of K for stability can be determined by use of Routh stability criterion. Since the closed-loop transfer function is

$$\frac{C(s)}{R(s)} = \frac{2K(s+1)}{s^4 + 7s^3 + 10s^2 + 2Ks + 2K}$$

the characteristic equation for the system is

$$s^4 + 7s^3 + 10s^2 + 2Ks + 2K = 0$$

The Routh array of coefficients becomes as follows:

$s^4$	1	10	2K	
$s^3$	7	2K		
$s^2$	$\frac{70-2K}{7}$	2K		
$s^1$	$\frac{\frac{(70-2K)2K}{7} - 14K}{7}$			0
$s^0$	2K			

For stability, we require

$$70 > 2K$$

$$42 - 4K > 0$$

$$K > 0$$

Thus, the range of K for stability is

$$10.5 > K > 0$$

B-6-11. The characteristic equation for the system is

$$s^3 + 4s^2 + 8s + K = 0$$

If K is set equal to 2, then the characteristic equation becomes

$$s^3 + 4s^2 + 8s + 2 = 0$$

The closed-loop poles are located as follows:

$$s = -1.8557 + j1.8669$$

$$s = -1.8557 - j1.8669$$

$$s = -0.2887$$

See the following MATLAB program for finding the closed-loop poles.

```
p = [1 4 8 2];
roots(p)

ans =

-1.8557 + 1.8669i
-1.8557 - 1.8669i
-0.2887
```

A MATLAB program to plot the root loci is shown below. The resulting root-locus plot is also shown below.

```
% ***** Root-locus plot *****

num = [0 0 0 1];
den = [1 4 8 0];
rlocus(num,den)
axis('square')
grid
title('Root-Locus Plot of G(s) = K/[s(s^2+4s+8)]')
```

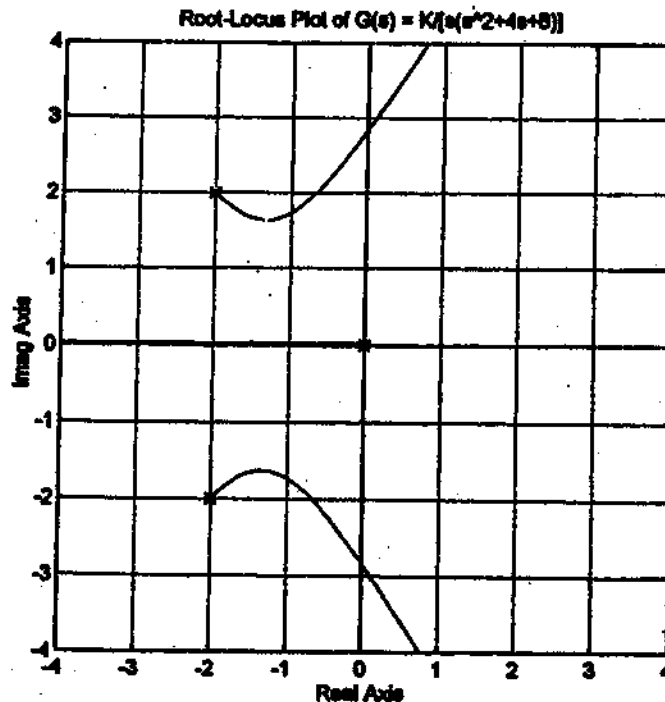

**B-6-12.** The open-loop transfer function for the system is

$$G(s)H(s) = \frac{K(s+1)}{(s^2+2s+2)(s^2+2s+5)}$$

A possible MATLAB program to plot a root-locus diagram is shown below. The resulting root-locus plot is also shown below.

```

num = [0 0 0 1 1];
den = [1 4 11 14 10];
K1 = 0:0.1:2;
K2 = 2:0.02:2.5;
K3 = 2.5:0.5:10;
K4 = 10:1:50;
K5 = 50:5:800;
K = [K1 K2 K3 K4 K5];
r = rlocus(num,den,K);
plot(r,'o')
v = [-8 2 -5 5]; axis(v)
grid
title('Root-Locus Plot of G(s) = K(s+1)/[(s^2+2s+2)(s^2+2s+5)]')
xlabel('Real Axis')
ylabel('Imag Axis')

```

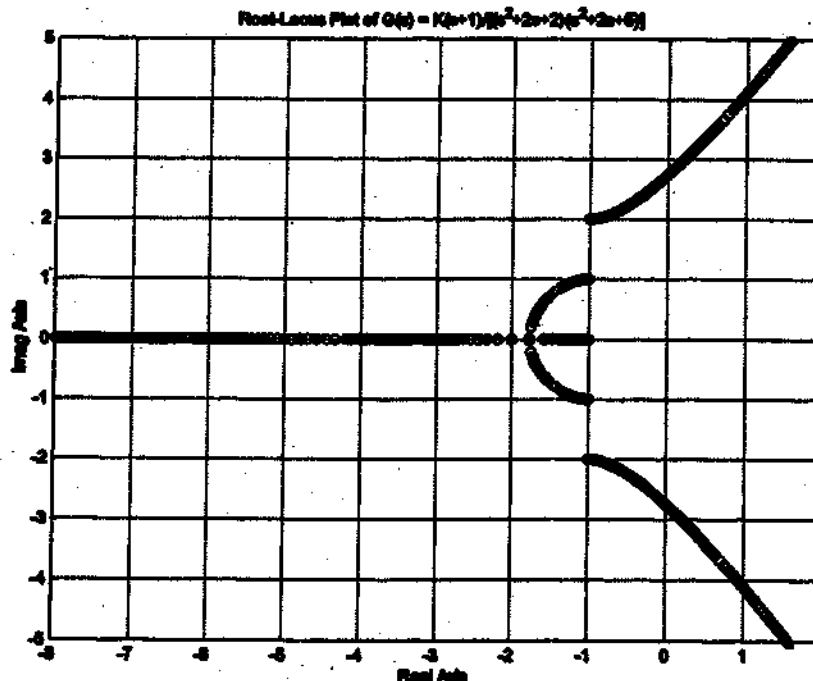

**B-6-13.** The open-loop transfer function is given by

$$G(s)H(s) = \frac{K(s-0.6667)}{s^2+3.3901s^2+7.0325s^2}$$

The equation for the asymptotes may be obtained as

$$\begin{aligned}
 G_a(s) H_a(s) &= \frac{K}{s^3 + (3.3401 + 0.6667) s^2 + \dots} \\
 &\doteq \frac{K}{\left(s + \frac{3.3401 + 0.6667}{3}\right)^3} \\
 &= \frac{K}{(s + 1.3356)^3} \\
 &= \frac{K}{s^3 + 4.0068s^2 + 5.3515s + 2.3825}
 \end{aligned}$$

Hence, we enter the following numerators and denominators in the program. For the system,

```

num = [0 0 0 1 -0.6667]
den = [1 3.3401 7.0325 0 0]

```

For the asymptotes,

```

numa = [0 0 0 1]
dena = [1 4.0068 5.3515 2.3825]

```

A MATLAB program to plot the root loci and asymptotes is given below. The resulting root-locus plot is shown on the next page.

```

% ***** Root-locus plot *****
num = [0 0 0 1 -0.6667];
den = [1 3.3401 7.0325 0 0];
numa = [0 0 0 1];
dena = [1 4.0068 5.3515 2.3825];
K1 = 0:1:50;
K2 = 50:5:200;
K = [K1 K2];
r = rlocus(num,den,K);
a = rlocus(numa,dena,K);
plot(r,'o')
v = [-6 2 -4 4]; axis(v); axis('square')
hold
Current plot held
plot(a,'-')
grid
title('Root-Locus Plot (Problem B-6-13)')
xlabel('Real Axis')
ylabel('Imag Axis')

```

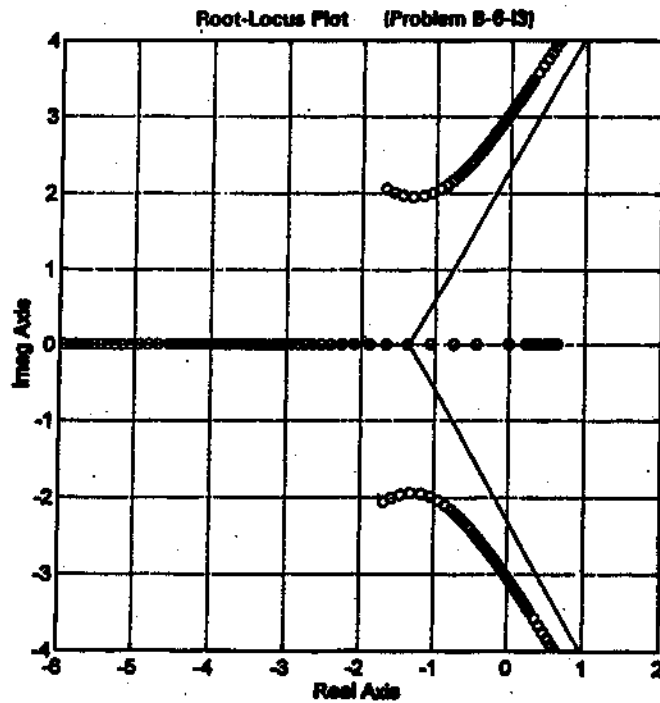

**B-6-14.** By substituting  $s = \sigma + j\omega$  into

$$\left| \frac{K}{s(s+1)} \right| = 1$$

and rewriting, we obtain

$$\begin{aligned} K &= |(\sigma + j\omega)(\sigma + j\omega + 1)| = |(\sigma + j\omega)^2 + \sigma + j\omega| \\ &= |\sigma^2 + \sigma - \omega^2 + j\omega(1 + 2\sigma)| \end{aligned}$$

Thus,

$$\begin{aligned} K^2 &= (\sigma^2 + \sigma - \omega^2)^2 + \omega^2(1 + 2\sigma)^2 \\ &= [\sigma(\sigma + 1) - \omega^2]^2 + \omega^2(1 + 4\sigma + 4\sigma^2) \\ &= [\sigma(\sigma + 1) + \omega^2]^2 + \omega^2 \end{aligned}$$

Hence

$$[\sigma(\sigma + 1) + \omega^2]^2 + \omega^2 = K^2$$

The constant gain loci for  $K = 1, 2, 5, 10,$  and  $20$  on the  $s$  plane are shown on the next page.

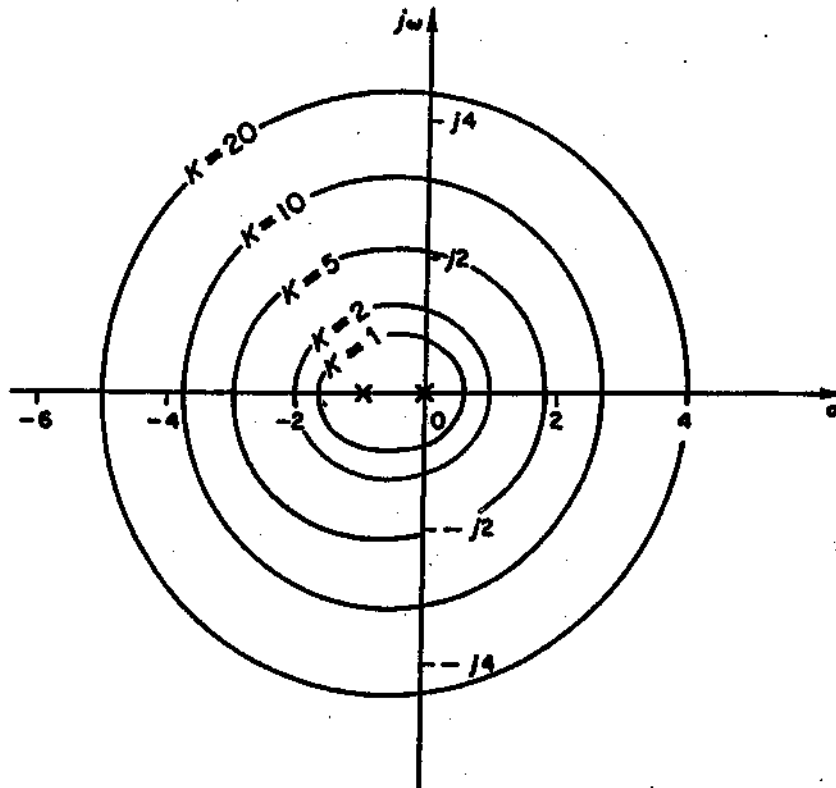

**B-6-15.** The term  $(s + 1)$  in the feedforward transfer function and the term  $(s + 1)$  in the feedback transfer function cancel each other. The reduced characteristic equation is

$$1 + G(s)H(s) = 1 + \frac{K(s+1)}{s(s^2+2s+6)} \frac{1}{s+1} = 1 + \frac{K}{s(s^2+2s+6)} = 0$$

The open-loop poles of  $G(s)H(s)$  is at  $s = 0$  and  $s = -1 \pm j\sqrt{5}$ . The following MATLAB program produces the root-locus plot shown on the next page.

```
% ***** Root-locus plot *****
num = [0 0 0 1];
den = [1 2 6 0];
rlocus(num,den)

Warning: Divide by zero
v = [-5 3 -4 4]; axis(v); axis('square')
grid
title('Root-Locus Plot (Problem B-6-15)')
```

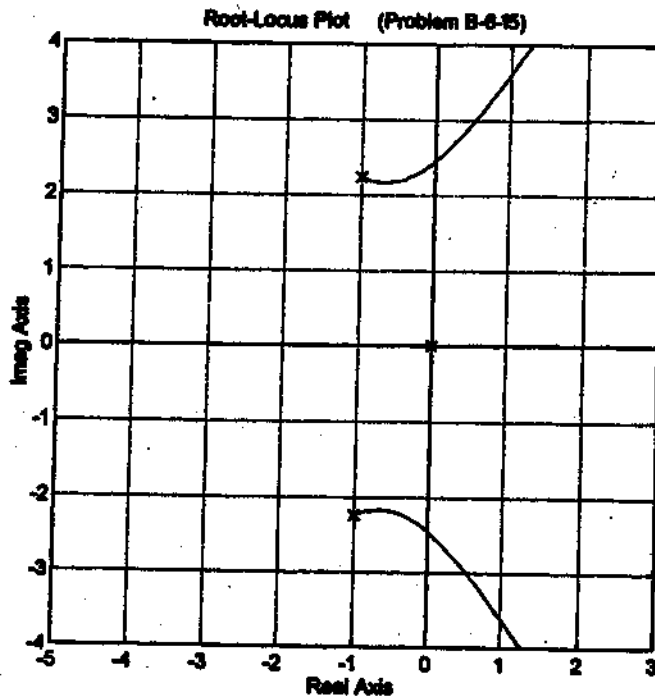

To find the closed-loop poles when the gain  $K$  is set equal to 2, we may enter the following MATLAB program into the computer.

```

p = [1 2 6 2];
roots(p)

ans =

-0.8147 + 2.1754i
-0.8147 - 2.1754i
-0.3706

```

Thus, the closed-loop poles are located at

$$s = -0.8147 \pm j 2.1754, \quad s = -0.3706$$

**B-6-16.** For the system shown in Figure 6-65(a):

A MATLAB program to plot a root-locus diagram for the system shown in Figure 6-65(a) is shown in MATLAB Program (a). The resulting root-locus plot is shown in Figure (a) (see next page).

```
% MATLAB Program (a):
```

```
num1 = [0 1 -1];  
den1 = [1 6 8];  
K1 = 0:0.01:50;  
K2 = 50:0.5:1000;  
K = [K1 K2];  
rlocus(num1,den1,K)  
grid  
title('Root-Locus Plot of  $G(s) = K(s-1)/(s^2+6s+8)$ ')  
xlabel('Real Axis')  
ylabel('Imag Axis')
```

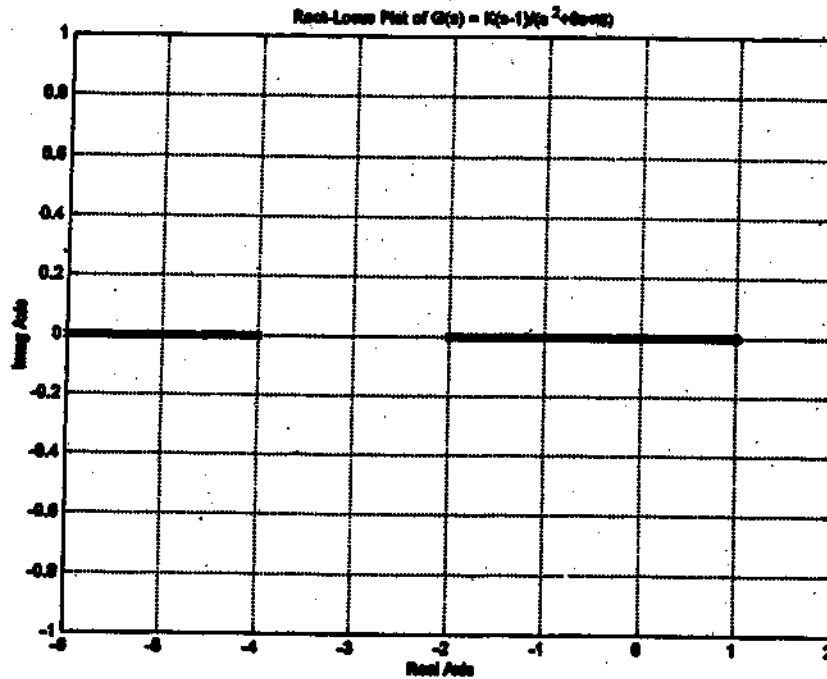

For the system shown in Figure 6-65(b):

A MATLAB program to produce a root-locus plot of the system shown in Figure 6-65(b) is given in MATLAB Program (b). The resulting root-locus plot is shown on the next page.

```
% MATLAB Program (b):
```

```
num2 = [0 -1 1];  
den2 = [1 6 8];  
K1 = 0:0.01:50;  
K2 = 50:0.5:1000;  
K = [K1 K2];  
rlocus(num2,den2,K)  
v = [-8 8 -8 8]; axis(v); axis('square')  
grid  
title('Root-Locus Plot of  $G(s) = K(1-s)/(s^2+6s+8)$ ')  
xlabel('Real Axis')  
ylabel('Imag Axis')
```

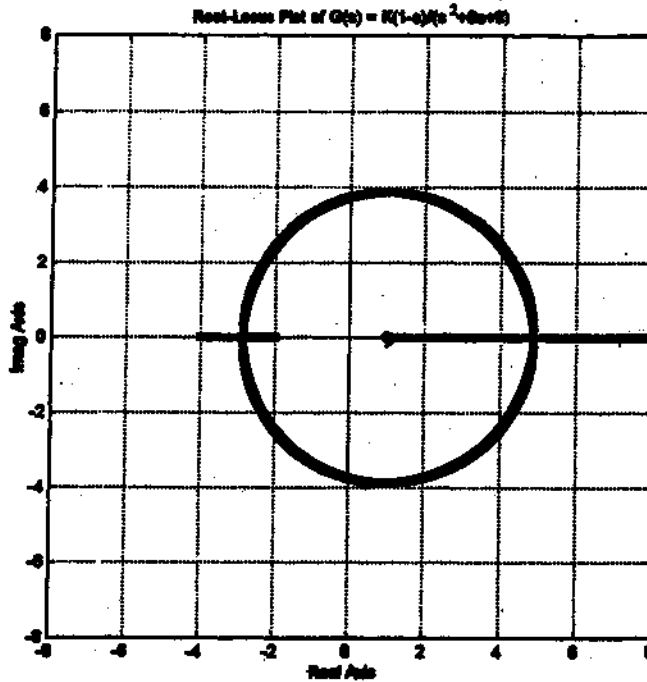

Note that the equations for the root loci for both systems are the same. They are given by

$$\omega[(\sigma-1)^2 + \omega^2 - 15] = 0$$

This equation is equivalent to

$$\omega = 0 \quad \text{or} \quad (\sigma-1)^2 + \omega^2 = 15$$

The first equation ( $\omega = 0$ ) is the equation for the real axis. The second equation is the equation for the circle with center at (1,0) and the radius equal to  $\sqrt{15}$ .

The equation for the break away or break-in points is obtained from  $dK/ds = 0$ . For both systems, the solutions for  $dK/ds = 0$  are

$$s = 4.873 \quad , \quad s = -2.873$$

For System (a):

$$K = -15.746 \quad \text{for } s = 4.873$$

$$K = -0.254 \quad \text{for } s = -2.873$$

This means that there are no break away or break-in points for System (a). The root loci exist only on the real axis. (The root loci exist between  $s = -2$  and  $s = 1$  and between  $s = -4$  and  $s = -\infty$ .)

For System (b):

$$K = 15.746 \quad \text{for } s = 4.873$$

$$K = 0.254 \quad \text{for } s = -2.873$$

Hence,  $s = -2.873$  and  $s = 4.873$  are actual break away and break-in points, respectively. The root loci involves the circular locus where the center of the circle is at  $(1,0)$  and the radius equal to  $\sqrt{15}$ . The root loci also exist on the real axis, from  $s = -2$  to  $s = -4$  and from  $s = 1$  to  $s = \infty$ .

**B-6-17.**

$$G(s) = \frac{2K}{100s+1} e^{-4s}$$

The characteristic equation for the closed-loop system is

$$1 + \frac{2K}{100s+1} e^{-4s} = 0$$

The angle condition is

$$\left| \frac{2K}{100s+1} e^{-4s} \right| = \left| e^{-4s} \right| - \left| 100s+1 \right| = \pm 180^\circ(2k+1)$$

Since

$$\begin{aligned} \left| e^{-4s} \right| &= \left| e^{-4j\omega} \right| = \left| \cos 4\omega - j \sin 4\omega \right| \\ &= -4\omega \text{ radians} \\ &= -229.2\omega \text{ degrees} \end{aligned}$$

The angle condition becomes

$$-229.2\omega - \left| s+0.01 \right| = \pm 180^\circ(2k+1)$$

For  $k = 0$ , the root-locus plot can be obtained as shown below.

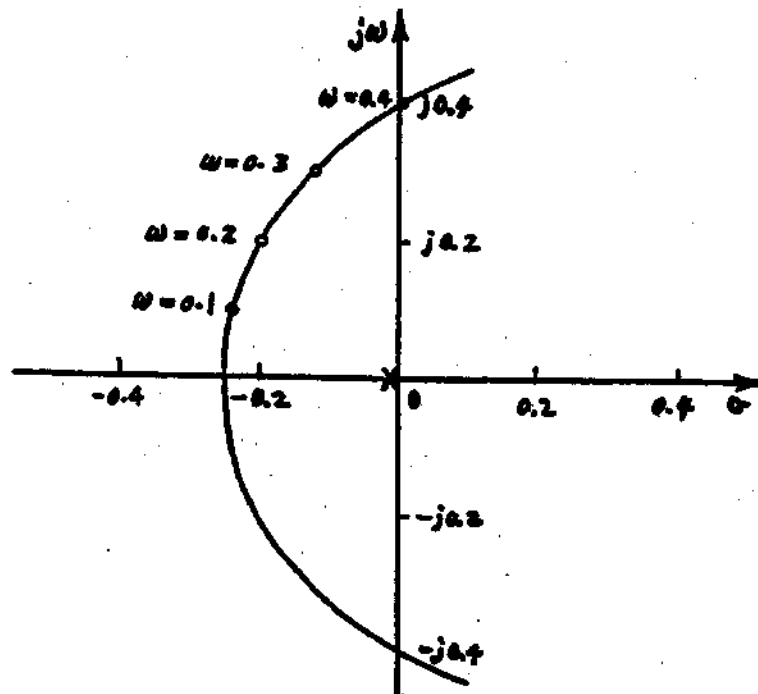

The magnitude condition states that

$$\left| \frac{2K}{100s+1} e^{-Ts} \right| = 1$$

Since

$$|e^{-Ts}| = |e^{-4\sigma}| \cdot |e^{-4j\omega}| = e^{-4\sigma}$$

The magnitude condition becomes as

$$|100s+1| = 2K e^{-4\sigma}$$

The root locus crosses the  $j\omega$  axis at  $\omega = 0.3927$ . By substituting  $\sigma = 0$ ,  $\omega = 0.3927$  into this last equation, we obtain the critical gain  $K_c$  as follows:

$$|100(j0.3927)+1| = 2K_c e^0$$

or

$$|1 + j39.27| = 2K_c$$

Solving for  $K_c$ , we get

$$K_c = 19.64$$

The critical gain for stability is 19.64. Hence the stability range for the gain  $K$  is

$$19.64 > K > 0$$

---

# CHAPTER 7

B-7-1. The differential equation for this mechanical system is

$$b_2(\dot{x}_i - \dot{x}_o) + k(x_i - x_o) = b_1 \dot{x}_o$$

Taking the Laplace transforms of both sides of this equation, assuming zero initial conditions and then rewriting, we obtain

$$\frac{X_o(s)}{X_i(s)} = \frac{b_2 s + k}{(b_1 + b_2)s + k} = \frac{\frac{b_2}{k}s + 1}{\frac{b_1 + b_2}{k}s + 1}$$

If we define

$$\frac{b_2}{k} = T, \quad \frac{b_1 + b_2}{b_2} = \beta > 1$$

then the transfer function  $X_o(s)/X_i(s)$  becomes

$$\frac{X_o(s)}{X_i(s)} = \frac{Ts + 1}{\beta Ts + 1} = \frac{1}{\beta} \left( \frac{s + \frac{1}{T}}{s + \frac{1}{\beta T}} \right)$$

This is a lag network, because the pole ( $s = -1/\beta T$ ) is located closer to the origin than the zero ( $s = -1/T$ ).

B-7-2. The complex impedances  $Z_1$  and  $Z_2$  are

$$Z_1 = R_1, \quad Z_2 = R_2 + \frac{1}{Cs}$$

The transfer function between the output voltage  $E_o(s)$  and the input voltage  $E_i(s)$  is given by

$$\frac{E_o(s)}{E_i(s)} = \frac{Z_2}{Z_1 + Z_2} = \frac{R_2 Cs + 1}{(R_1 + R_2)Cs + 1}$$

Define

$$R_2 C = T, \quad \frac{R_1 + R_2}{R_2} = \beta > 1$$

Then, the transfer function becomes

$$\frac{E_o(s)}{E_i(s)} = \frac{Ts + 1}{\beta Ts + 1} = \frac{1}{\beta} \left( \frac{s + \frac{1}{T}}{s + \frac{1}{\beta T}} \right)$$

This is a lag network.

---

B-7-3.

$$G_c(s) = \frac{3.5s + 1.4}{s + 2} = \frac{3.5(s + 0.4)}{s + 2}$$

The zero ( $s = -0.4$ ) is located closer to the origin than the pole ( $s = -2$ ). Hence  $G_c(s)$  is a lead network.

---

B-7-4.

$$G_c(s) = K \frac{s + b}{s + a} \quad (a > 0, b > 0, K > 0)$$

For this  $G_c(s)$  to be a lead network, we require

$$b < a$$

---

B-7-5.

$$G_c(s) = \frac{5(s+1)}{s+8} = \frac{5}{8} \frac{s+1}{0.125s+1}$$

An op-amp lead controller is shown below.

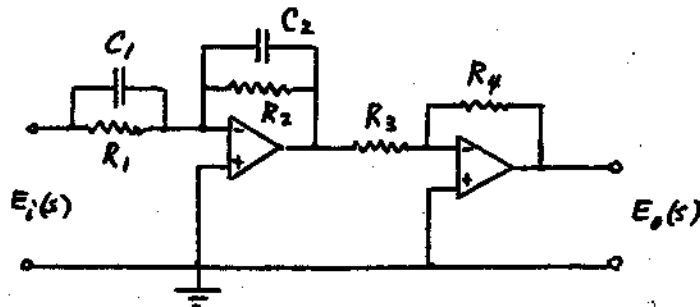

The transfer function of this op-amp circuit is

$$\frac{E_o(s)}{E_i(s)} = \frac{R_2 R_4}{R_1 R_3} \frac{R_1 C_1 s + 1}{R_2 C_2 s + 1}$$

If we arbitrarily choose,  $C_1 = C_2 = 10 \mu\text{F}$  and  $R_3 = 10 \text{ k}\Omega$ , then

$$R_1 = 100 \text{ k}\Omega, \quad R_2 = 12.5 \text{ k}\Omega$$

Since  $R_2 R_4 / (R_1 R_3)$  must be equal to  $5/8$ , we obtain

$$\frac{12.5 \times 10^3 R_4}{100 \times 10^3 \times 10 \times 10^3} = \frac{5}{8}$$

or

$$R_4 = 50 \text{ k}\Omega$$

Thus, we determined  $C_1$ ,  $C_2$ ,  $R_1$ ,  $R_2$ ,  $R_3$ , and  $R_4$  as follows:

$$C_1 = 10 \mu F, \quad C_2 = 10 \mu F, \quad R_1 = 100 k \Omega$$

$$R_2 = 12.5 k \Omega, \quad R_3 = 10 k \Omega, \quad R_4 = 50 k \Omega$$

**B-7-6.** The following MATLAB program gives a root-locus plot for the system. The plot obtained is shown below.

```

% ***** Root-locus plot *****

num = [0 0 0 1];
den = [1 4 5 0];
rlocus(num,den)
hold
Current plot held
x = [0 -2]; y = [0 3.464]; line(x,y)
axis('square')
grid
title('Root-Locus Plot')
    
```

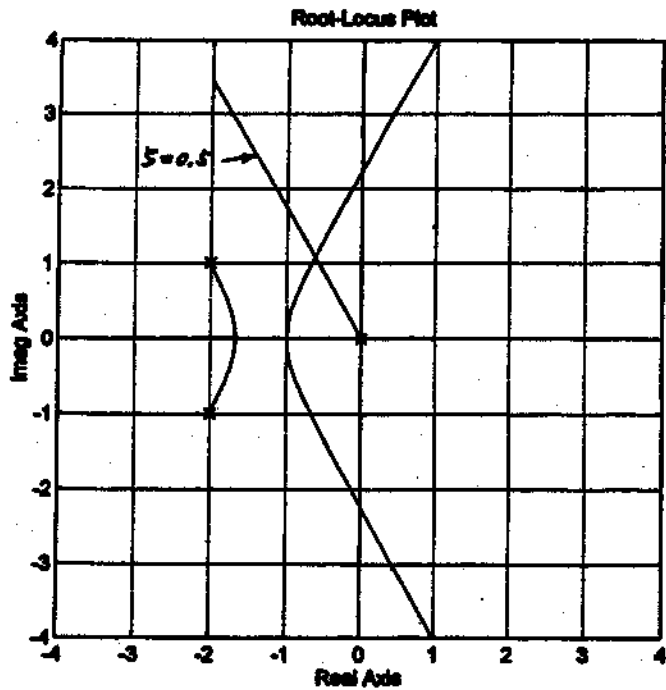

Since the dominant closed-loop poles have the damping ratio  $\zeta$  of 0.5, we may write them as

$$s = x \pm j\sqrt{3}x$$

The characteristic equation for the system is

$$s^3 + 4s^2 + 5s + K = 0$$

By substituting  $s = x + j\sqrt{3}x$  into this equation, we obtain

$$(x+j\sqrt{3}x)^3 + 4(x+j\sqrt{3}x)^2 + 5(x+j\sqrt{3}x) + K = 0$$

or

$$-8x^3 - 8x^2 + 5x + K + 2\sqrt{3}j(4x^2 + 2.5x) = 0$$

By equating the real part and imaginary part to zero, respectively, we get

$$-8x^3 - 8x^2 + 5x + K = 0 \quad (1)$$

$$4x^2 + 2.5x = 0 \quad (2)$$

Noting that  $x \neq 0$ , from Equation (2), we obtain

$$4x + 2.5 = 0$$

or

$$x = -0.625$$

By substituting  $x = -0.625$  into Equation (1), we get

$$\begin{aligned} K &= 8x^3 + 8x^2 - 5x \\ &= 8(-0.625)^3 + 8(-0.625)^2 - 5(-0.625) \\ &= 4.296875 \end{aligned}$$

To determine all closed-loop poles, we may enter the following MATLAB program into the computer.

```
p = [1 4 5 4.296875];
roots(p)

ans =

-2.7500
-0.6250 + 1.0825i
-0.6250 - 1.0825i
```

Thus, the closed-loop poles are located at  $s = -0.625 \pm j1.0825$  and  $s = -2.75$ .

The unit-step response curve can be obtained by entering the following MATLAB program into the computer. The resulting unit-step response curve is shown on the next page.

```
% ***** Unit-Step Response *****
num = [0 0 0 4.2969];
den = [1 4 5 4.2969];
step(num,den)
grid
title('Unit-Step Response')
```

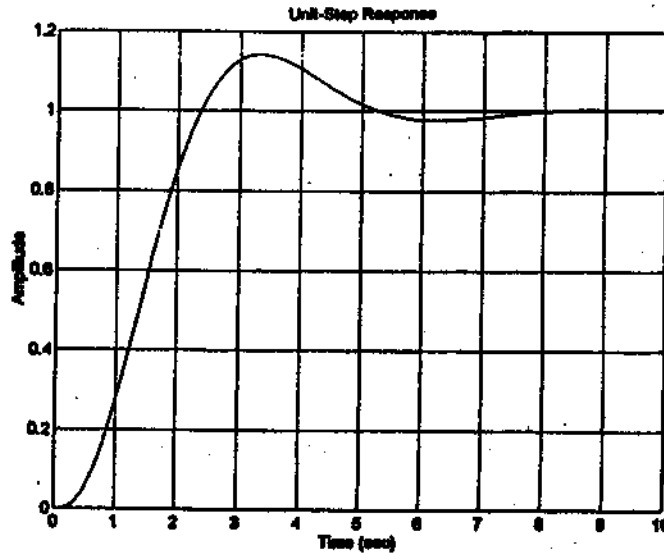

**B-7-7.** The solution to such a problem is not unique. We shall present two solutions to the problem in what follows. Note that from the requirement stated in the problem, the dominant closed-loop poles must have  $\zeta = 0.5$  and  $\omega_n = 3$ , or

$$s = -1.5 \pm j 2.5981$$

Notice that the angle deficiency is

$$\text{Angle deficiency} = 180^\circ - 120^\circ - 100.894^\circ = -40.894^\circ$$

**Method 1:** If we choose the zero of the lead compensator at  $s = -1$  so that it will cancel the plant pole at  $s = -1$ , then the compensator pole must be located at  $s = -3$ , or

$$G_c(s) = K \frac{T_1 s + 1}{T_2 s + 1} = \frac{K T_1}{T_2} \left( \frac{s + \frac{1}{T_1}}{s + \frac{1}{T_2}} \right) = \frac{K T_1}{T_2} \frac{s + 1}{s + 3}$$

or

$$G_c(s) = 3K \frac{s + 1}{s + 3}$$

The value of  $K$  can be determined by use of the magnitude condition.

$$\left| 3K \frac{s + 1}{s + 3} \frac{10}{s(s + 1)} \right|_{s = -1.5 + j 2.5981} = 1$$

or

$$K = \left| \frac{s(s + 3)}{30} \right|_{s = -1.5 + j 2.5981} = 0.3$$

Hence

$$G_c(s) = 0.9 \frac{s + 1}{s + 3}$$

The open-loop transfer function is

$$G_c(s)G(s) = \frac{9}{s(s+3)}$$

The closed-loop transfer function  $C(s)/R(s)$  becomes as follows:

$$\frac{C(s)}{R(s)} = \frac{9}{s^2 + 3s + 9}$$

Method 2: Referring to the figure shown below, if we bisect angle OPA and take  $20.447^\circ$  each side, then the locations of the zero and pole are found as follows:

zero at  $s = -1.9432$

pole at  $s = -4.6458$

Thus,  $G_c(s)$  can be given as

$$G_c(s) = K \frac{T_1 s + 1}{T_2 s + 1} = K \frac{T_1}{T_2} \frac{s + 1.9432}{s + 4.6458} = 2.391 K \frac{s + 1.9432}{s + 4.6458}$$

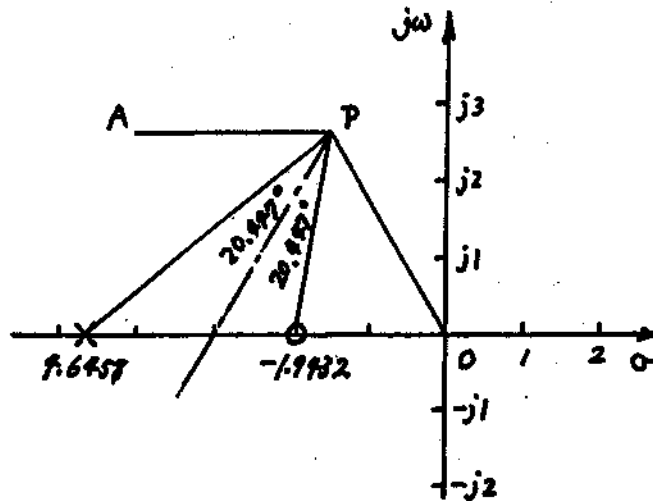

The value of  $K$  can be determined by use of the magnitude condition.

$$\left| 2.391 K \frac{s + 1.9432}{s + 4.6458} \frac{10}{s(s+1)} \right|_{s = -1.5 + j 2.5981} = 1$$

or

$$K = \left| \frac{(s + 4.6458) s (s + 1)}{23.91 (s + 1.9432)} \right|_{s = -1.5 + j 2.5981} = 0.5138$$

Hence, the compensator  $G_c(s)$  is given by

$$G_c(s) = 1.2285 \frac{s + 1.9432}{s + 4.6458} = 0.5138 \frac{0.5146s + 1}{0.2152s + 1}$$

Then, the open-loop transfer function becomes as

$$G_c(s)G(s) = 0.5138 \left( \frac{0.5146s + 1}{0.2152s + 1} \right) \frac{10}{s(s+1)}$$

The closed-loop transfer function is

$$\begin{aligned} \frac{C(s)}{R(s)} &= \frac{5.138 (0.51465s + 1)}{s(s+1)(0.2152s + 1) + 5.138 (0.51465s + 1)} \\ &= \frac{2.644s + 5.138}{0.2152s^3 + 1.2152s^2 + 3.644s + 5.138} \end{aligned}$$

It is interesting to compare the static velocity error constants for the two systems designed above.

For the system designed by Method 1:

$$K_v = \lim_{s \rightarrow 0} s \frac{9}{s(s+3)} = 3$$

For the system designed by Method 2:

$$K_v = \lim_{s \rightarrow 0} s (0.5138) \frac{0.51465s + 1}{0.2152s + 1} \frac{10}{s(s+1)} = 5.138$$

The system designed by Method 2 gives a larger value of the static velocity error constant. This means that the system designed by Method 2 will give smaller steady-state errors in following ramp inputs than the system designed by Method 1.

In what follows, we compare the unit-step responses of the three systems: the original uncompensated system, the system designed by Method 1, and the system designed by Method 2. The MATLAB program used to obtain the unit-step response curves is given below. The resulting unit-step response curves are shown on the next page.

```
% ***** Comparison of unit-step responses for three systems *****
num = [0 0 10];
den = [1 1 10];
num1 = [0 0 9];
den1 = [1 3 9];
num2 = [0 0 2.644 5.138];
den2 = [0.2152 1.2152 3.644 5.138];
t = 0:0.02:8;
c = step(num,den,t);
c1 = step(num1,den1,t);
c2 = step(num2,den2,t);
plot(t,c,'.',t,c1,'-',t,c2,'-');
grid
title('Comparison of Unit-Step Responses for Three Systems')
xlabel('t Sec')
ylabel('Outputs')
text(1.5,1.5,'Uncompensated system')
text(1.1,0.5,'Compensated system with K = 0.5138, T1 = 0.5146, T2 = 0.2152')
text(1.1,0.3,'Compensated system with K = 0.3, T1 = 1, T2 = 0.3333')
```

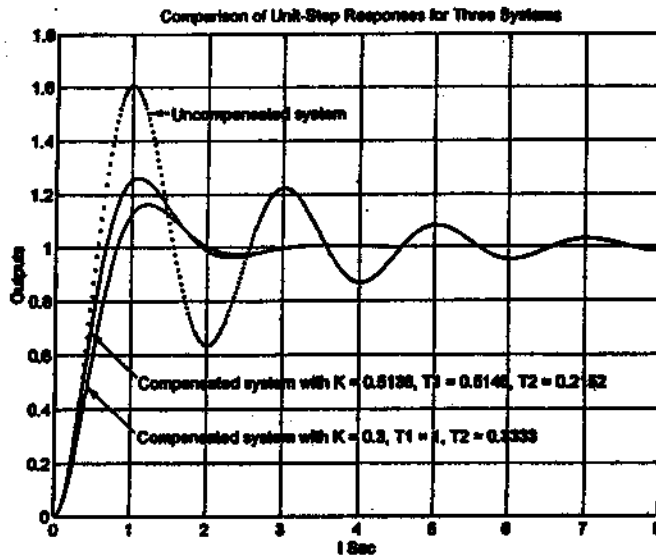

**B-7-8.** The closed-loop transfer function  $C(s)/R(s)$  is given by

$$\frac{C(s)}{R(s)} = \frac{K(Ts+1)}{s(s+2) + K(Ts+1)}$$

Since the closed-loop poles are specified to be

$$s = -2 \pm j^2$$

we obtain

$$s(s+2) + K(Ts+1) = (s+2+j^2)(s+2-j^2)$$

or

$$s^2 + (2+KT)s + K = s^2 + 4s + 8$$

Hence, we require

$$2+KT = 4, \quad K = 8$$

which results in

$$T = 0.25, \quad K = 8$$



**B-7-9.** The angle deficiency at the closed-loop pole  $s = -2 + j2\sqrt{3}$  is

$$180^\circ - 120^\circ - 90^\circ = -30^\circ$$

The lead compensator must contribute  $30^\circ$ .

Let us choose the zero of the lead compensator at  $s = -2$ . Then, the pole of the compensator must be located at  $s = -4$ . Thus,

$$G_c(s) = K \frac{s+2}{s+4}$$

The gain  $K$  is determined from the magnitude condition.

$$\left| K \frac{s+2}{s+4} \frac{s}{s(0.5s+1)} \right|_{s=-2+j2\sqrt{3}} = 1$$

or

$$K = \left| \frac{s(s+4)}{10} \right|_{s=-2+j2\sqrt{3}} = 1.6$$

Hence,

$$G_c(s) = 1.6 \frac{s+2}{s+4}$$

Next, we shall obtain unit-step responses of the original system and the compensated system. The original system has the following closed-loop transfer function:

$$\frac{C(s)}{R(s)} = \frac{10}{s^2 + 2s + 10}$$

The compensated system has the following closed-loop transfer function:

$$\frac{C(s)}{R(s)} = \frac{16}{s^2 + 4s + 16}$$

The unit-step response curves of the original system and compensated system are shown below.

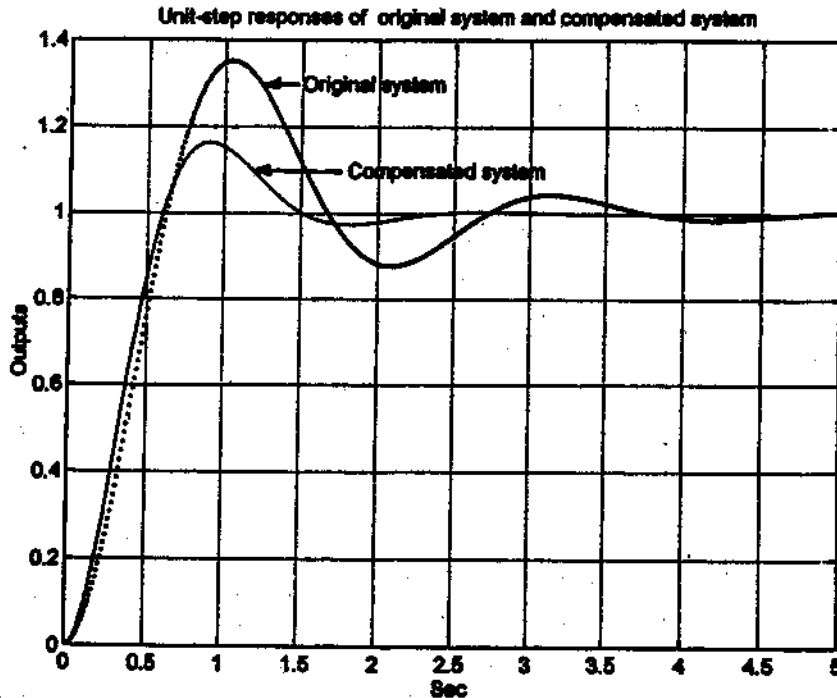

B-7-10. The angle deficiency is

$$180^\circ - 135^\circ - 135^\circ = -90^\circ$$

A lead compensator can contribute  $90^\circ$ . Let us choose the zero of the lead

compensator at  $s = -0.5$ . Then, the pole of the compensator must be at  $s = -3$ . Thus,

$$G_c(s) = K \frac{s+0.5}{s+3}$$

The gain  $K$  can be determined from the magnitude condition.

$$\left| K \frac{s+0.5}{s+3} \frac{1}{s^2} \right|_{s=-1+j} = 1$$

or

$$K = \left| \frac{(s+3) s^2}{s+0.5} \right|_{s=-1+j} = 4$$

Hence the lead compensator becomes as follows:

$$G_c(s) = 4 \frac{s+0.5}{s+3}$$

The feedforward transfer function is

$$G_c(s) G(s) = \frac{4s+2}{s^3+3s^2}$$

A root-locus plot of the system is shown below.

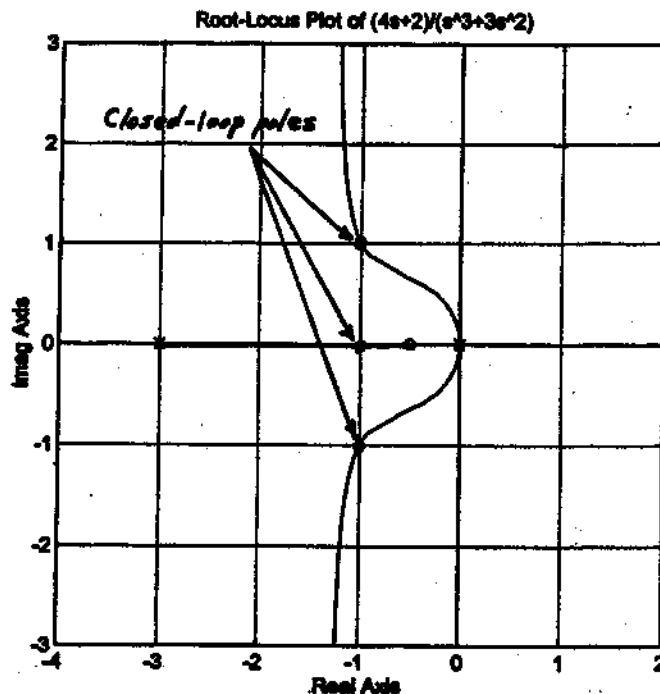

Note that the closed-loop transfer function is

$$\frac{C(s)}{R(s)} = \frac{4s+2}{s^3+3s^2+4s+2}$$

The closed-loop poles are located at  $s = -1 \pm j1$  and  $s = -1$ .

In what follows we shall give the unit-step and unit-ramp responses of the uncompensated system and the compensated system. A MATLAB program to obtain

unit-step response curves is given below. The resulting curves are also shown below.

```

% ***** Unit-step responses of uncompensated and compensated systems *****
num = [0 0 1];
den = [1 0 1];
numc = [0 0 4 2];
denc = [1 3 4 2];
t = 0:0.02:10;
c1 = step(num,den,t);
c2 = step(numc,denc,t);
plot(t,c1,'-',t,c2,'-')
grid
title('Unit-step responses of uncompensated and compensated systems')
xlabel('Sec')
ylabel('Outputs')
text(3,0.9,'Compensated system')
text(3,1.5,'Uncompensated system')

```

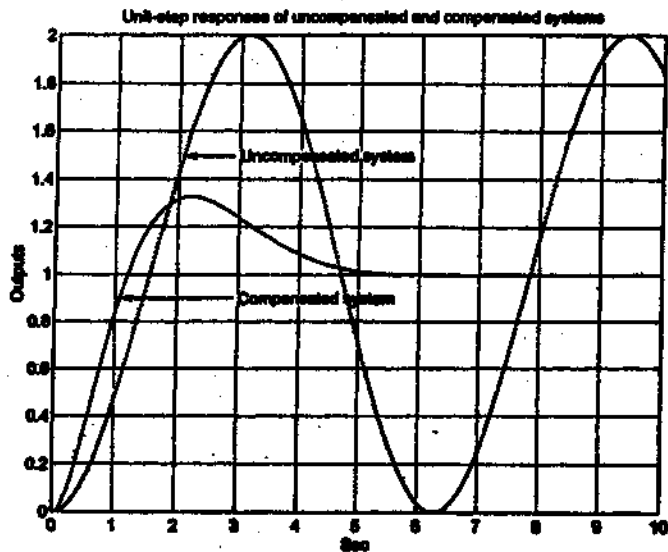

A MATLAB program to obtain unit-ramp response curves is given next. The resulting response curves are shown on the next page.

```

% ***** Unit-ramp responses of uncompensated and compensated systems *****
num = [0 0 0 1];
den = [1 0 1 0];
numc = [0 0 0 4 2];
denc = [1 3 4 2 0];
t = 0:0.02:15;
c1 = step(num,den,t);
c2 = step(numc,denc,t);
plot(t,t,'-',t,c1,'-',t,c2,'-')
grid
title('Unit-ramp responses of uncompensated and compensated systems ')
xlabel('t Sec')
ylabel('Input and Outputs')
text(4,1.5,'Compensated system')
text(8,6,'Uncompensated system')

```

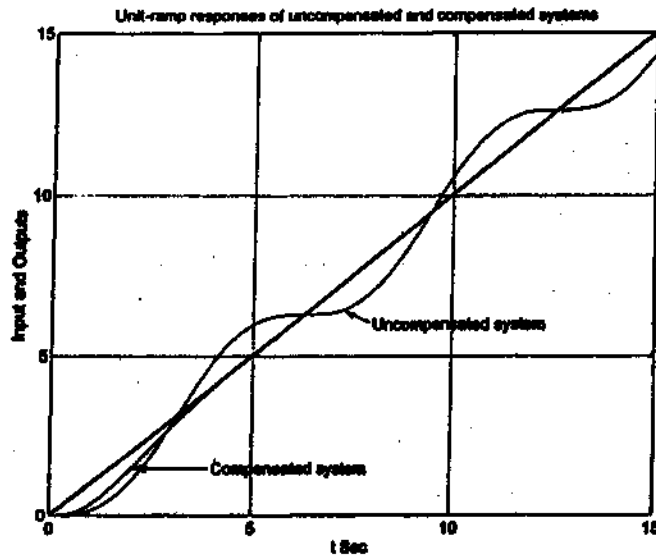

**B-7-11.** The original uncompensated system has the following closed-loop transfer function:

$$\frac{C(s)}{R(s)} = \frac{16}{s^2 + 4s + 16}$$

The two closed-loop poles are located at  $s = -2 \pm j2\sqrt{3}$ . Choose a lag compensator of the following form:

$$G_c(s) = K_c \frac{s + \frac{1}{T}}{s + \frac{1}{\beta T}}, \quad (\beta > 1)$$

Then, the static velocity error constant  $K_v$  can be given by

$$K_v = \lim_{s \rightarrow 0} s G_c(s) G(s) = \lim_{s \rightarrow 0} s K_c \frac{s + \frac{1}{T}}{s + \frac{1}{\beta T}} \frac{16}{s(s+4)} = 9\beta K_c = 20$$

Let us choose  $K_c = 1$ . Then

$$\beta = 5$$

The pole and zero of the lag compensator must be located close to the origin. Let us choose  $T = 20$ . Then, the lag compensator becomes

$$G_c(s) = \frac{s + \frac{1}{20}}{s + \frac{1}{100}} = \frac{s + 0.05}{s + 0.01}$$

Notice that

$$\left| \frac{s + 0.05}{s + 0.01} \right|_{s = -2 + j2\sqrt{3}} = 0.9950$$

$$\angle \frac{s + 0.05}{s + 0.01} \Big|_{s = -2 + j2\sqrt{3}} = \angle [-1.95 + j2\sqrt{3}] - \angle [-1.99 + j2\sqrt{3}]$$

$$= -60.6241^\circ + 60.1242^\circ = -0.4999^\circ$$

The angle contribution of this lag network is very small ( $-0.4999^\circ$ ) and the magnitude of  $G_c(s)$  is approximately unity at the desired closed-loop pole. Hence, the designed lag compensator is satisfactory. Thus

$$G_c(s) = \frac{s+0.05}{s+0.01}$$

Let us compare the unit-step response curves of the uncompensated and compensated systems. The closed-loop transfer function of the uncompensated system is

$$\frac{C(s)}{R(s)} = \frac{16}{s^2 + 4s + 16}$$

For the compensated system the closed-loop transfer function is

$$\begin{aligned} \frac{C(s)}{R(s)} &= \frac{16(s+0.05)}{(s+0.01)s(s+4) + 16(s+0.05)} \\ &= \frac{16s + 0.8}{s^3 + 4.01s^2 + 16.04s + 0.8} \end{aligned}$$

The closed-loop poles can be found by entering the following MATLAB program into the computer.

```
p = [1 4.01 16.04 0.8];
roots(p)

ans =

-1.9797 + 3.4526i
-1.9797 - 3.4526i
-0.0505
```

The dominant closed-loop poles are located at  $s = -1.9797 \pm j3.4526$ . These locations are very close to the original closed-loop poles.

The following MATLAB program produces a plot of unit-step response curves.

```
% ***** Comparison of Unit-Step Responses for Two Systems *****

num = [0 0 16];
den = [1 4 16];
numc = [0 0 16 0.8];
denc = [1 4.01 16.04 0.8];
t = 0:0.02:5;
c1 = step(num,den,t);
c2 = step(numc,denc,t);
plot(t,c1,'-',t,c2,'-')
grid
title('Unit-Step Responses of Uncompensated and Compensated Systems')
xlabel('Sec')
ylabel('Outputs')
text(1.5,1.1,'Compensated system')
text(1.5,0.9,'Uncompensated system')
```

The unit-step response curves obtained are shown below.

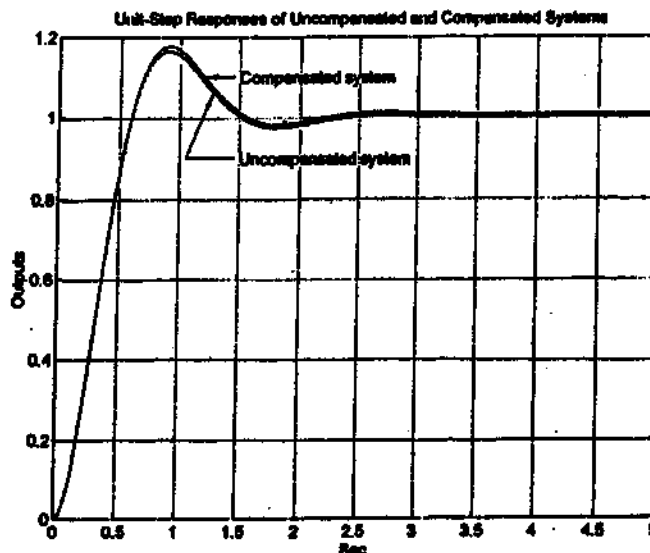

Clearly, the unit-step response curves for the two systems are approximately the same.

For the unit-ramp response, the response curves for the two systems differ, because the original uncompensated system gives the steady-state error of 0.25, while the compensated system exhibits the steady-state error of 0.05. The following MATLAB program gives the unit-ramp response curves in the time range  $95 \text{ sec} \leq t \leq 100 \text{ sec}$ . The resulting unit-ramp response curves are shown on the next page.

```

% ***** Comparison of Unit-Ramp Responses for Two Systems *****
num = [0 0 0 16];
den = [1 4 16 0];
numc = [0 0 0 16 0.8];
denc = [1 4.01 16.04 0.8 0];
t = 0:0.1:100;
c1 = step(num,den,t);
c2 = step(numc,denc,t);
plot(t,t,'-',t,c1,'-.',t,c2,'-')
v = [95 100 95 100]; axis(v)
grid
title('Unit-Ramp Responses of Uncompensated and Compensated Systems')
xlabel('Sec')
ylabel('Input and Outputs')
text(95.5,97.7,'Compensated system')
text(97.5,96.7,'Uncompensated system')

```

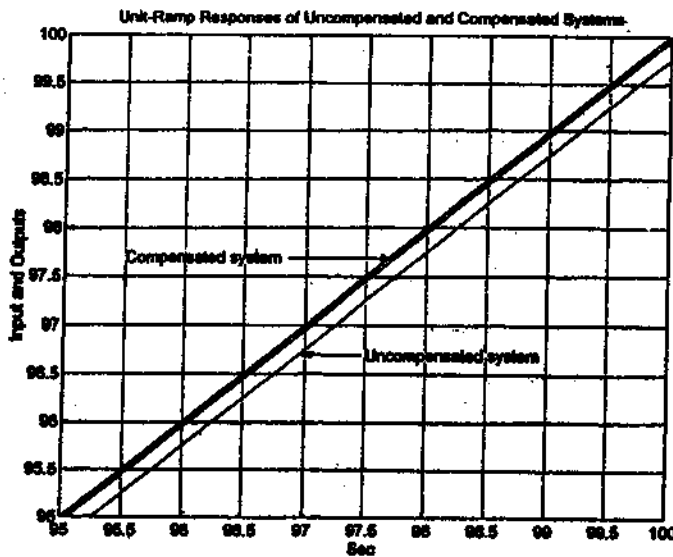

B-7-12. Since the characteristic equation of the uncompensated system is

$$s^3 + 30s^2 + 200s + 820 = 0$$

the uncompensated system has the closed-loop poles at

$$s = -3.60 \pm j 4.80, \quad s = -22.8$$

To increase the static velocity error constant from  $4.1$  to  $41 \text{ sec}^{-1}$  without appreciably changing the location of the dominant closed-loop poles, we need to insert a lag compensator  $G_c(s)$  whose pole and zero are located very close to the origin. For example, we may choose

$$G_c(s) = 10 \frac{Ts + 1}{10Ts + 1}$$

where  $T$  may be chosen to be  $4$ , or  $T = 4$ . Then the lag compensator becomes

$$G_c(s) = 10 \frac{4s + 1}{40s + 1} = \frac{s + 0.25}{s + 0.025} \quad (1)$$

The angle contribution of this lag network at  $s = -3.60 + j 4.80$  is  $-1.77^\circ$ , which is acceptable in the present problem.

The open-loop transfer function of the compensated system becomes

$$G_c(s)G(s) = \frac{820(s + 0.25)}{s(s + 0.025)(s + 10)(s + 20)}$$

Clearly, the velocity error constant  $K_v$  for the compensated system is

$$K_v = \lim_{s \rightarrow 0} s G_c(s)G(s) = 41 \text{ sec}^{-1}$$

Notice that because of the addition of the lag compensator the compensated system becomes of fourth order. The characteristic equation for the compensated system is

$$s^4 + 30.025s^3 + 200.75s^2 + 825s + 205 = 0$$

The roots of this characteristic equation can be easily obtained by use of MATLAB as shown below.

```
p = [1 30.025 200.75 825 205];
roots(p)

ans =

-22.7866
-3.4868 + 4.6697i
-3.4868 - 4.6697i
-0.2649
```

Thus, the dominant closed-loop poles are located at

$$s = -3.4868 \pm j 4.6697$$

The other two closed-loop poles are located at

$$s = -0.2649, \quad s = -22.787$$

The closed-loop pole at  $s = -0.2648$  almost cancels the zero of the lag compensator,  $s = -0.25$ . Also, since the closed-loop pole at  $s = -22.787$  is located very farther to the left compared to the complex-conjugate closed-loop poles, the effect of this pole on the system response is very small. Therefore, the closed-loop poles at  $s = -3.4868 \pm j 4.6697$  are indeed the dominant closed-loop poles.

The undamped natural frequency  $\omega_n$  of the dominant closed-loop poles is

$$\omega_n = \sqrt{3.4868^2 + 4.6697^2} = 5.828 \text{ rad/sec}$$

Since the original uncompensated system has the undamped natural frequency of 6 rad/sec, the compensated system has an approximately 3% smaller value, which would be acceptable. Hence, the lag compensator given by Equation (1) is satisfactory.

B-7-13. Let us choose a lag-lead compensator as given below.

$$G_c(s) = K_c \frac{(s + \frac{1}{T_1})(s + \frac{1}{T_2})}{(s + \frac{\beta}{T_1})(s + \frac{1}{\beta T_2})} \quad (\beta > 1)$$

The desired closed-loop poles are located at

$$s = -2 \pm j 2\sqrt{3}$$

and the static velocity error constant  $K_v$  is specified as

$$K_v = 50 \text{ sec}^{-1}$$

The open-loop transfer function of the compensated system is

$$G_c(s)G(s) = K_c \frac{(s + \frac{1}{T_1})(s + \frac{1}{T_2})}{(s + \frac{\beta}{T_1})(s + \frac{1}{\beta T_2})} \frac{10}{s(s+2)(s+5)}$$

Hence

$$K_v = \lim_{s \rightarrow 0} s G_c(s)G(s) = \lim_{s \rightarrow 0} K_c \frac{10}{2 \times 5} = K_c = 50$$

Thus

$$K_c = 50$$

The time constant  $T_1$  and the value of  $\beta$  are determined from the requirements that

$$\left| \frac{s + \frac{1}{T_1}}{s + \frac{\beta}{T_1}} \right| \left| \frac{50 \times 10}{s(s+2)(s+5)} \right|_{s = -2 + j2\sqrt{3}} = 1$$

$$\left| \frac{s + \frac{1}{T_1}}{s + \frac{\beta}{T_1}} \right|_{s = -2 + j2\sqrt{3}} = 79.1066^\circ$$

The angle  $79.1066^\circ$  comes from the fact that the lead portion must compensate the angle deficiency which is

$$\text{Angle deficiency} = 180^\circ - 120^\circ - 90^\circ - 49.1066^\circ = -79.1066^\circ$$

See the diagram shown below.

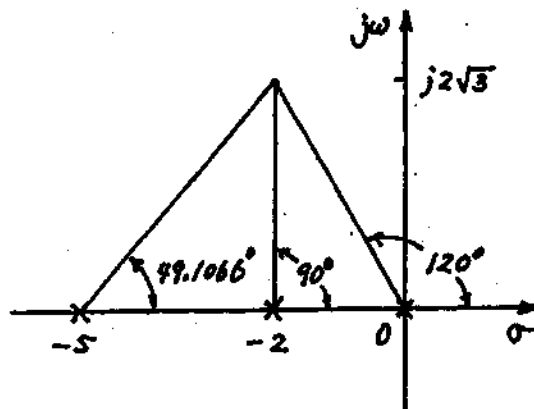

By using trigonometry we find the locations of the zero and pole of the lead portion of the compensator as follows:

$$\frac{s + \frac{1}{T_1}}{s + \frac{\beta}{T_1}} = \frac{s + 2.2187}{s + 27.1111}$$

Hence,

$$T_1 = 0.4507, \quad \beta = 12.2194$$

For the lag portion, we may choose  $T_2 = 10$ . Then, the lag portion may be given by

$$\frac{s + \frac{1}{T_2}}{s + \frac{1}{\beta T_2}} = \frac{s + 0.1}{s + 0.008184}$$

Notice that

$$\left| \frac{s + \frac{1}{T_2}}{s + \frac{1}{\beta T_2}} \right|_{s = -2 + j2\sqrt{3}} = \left| \frac{s + 0.1}{s + 0.008184} \right|_{s = -2 + j2\sqrt{3}}$$

$$= 0.9888$$

$$\angle \frac{s + \frac{1}{T_2}}{s + \frac{1}{\beta T_2}} \Big|_{s = -2 + j2\sqrt{3}} = -1.1544^\circ$$

The changes caused by the lag portion are small and acceptable. Hence the lag-lead compensator can be given by

$$G_c(s) = 50 \frac{s + 2.2187}{s + 27.1111} \frac{s + 0.1}{s + 0.008184}$$

The compensated system will have the open-loop transfer function

$$G_c(s)G(s) = \frac{50(s + 2.2187)(s + 0.1)}{(s + 27.1111)(s + 0.008184)} \cdot \frac{10}{s(s + 2)(s + 5)}$$

$$= \frac{500s^2 + 1159.35s + 110.935}{s^5 + 34.1193s^4 + 200.0570s^3 + 272.7462s^2 + 2.2188s}$$

The closed-loop transfer function becomes as follows:

$$\frac{C(s)}{R(s)} = \frac{500s^2 + 1159.35s + 110.935}{s^5 + 34.1193s^4 + 200.0570s^3 + 272.7462s^2 + 111.5688s + 110.935}$$

The following MATLAB program will give the unit-step response of the compensated system.

```

% ***** Unit-step response *****
num = [0 0 0 500 1159.35 110.935];
den = [1 34.1193 200.0570 772.7462 1161.5688 110.935];
step(num,den)
grid
title('Unit-Step Response of Compensated System')
    
```

The resulting unit-step response curve is shown below.

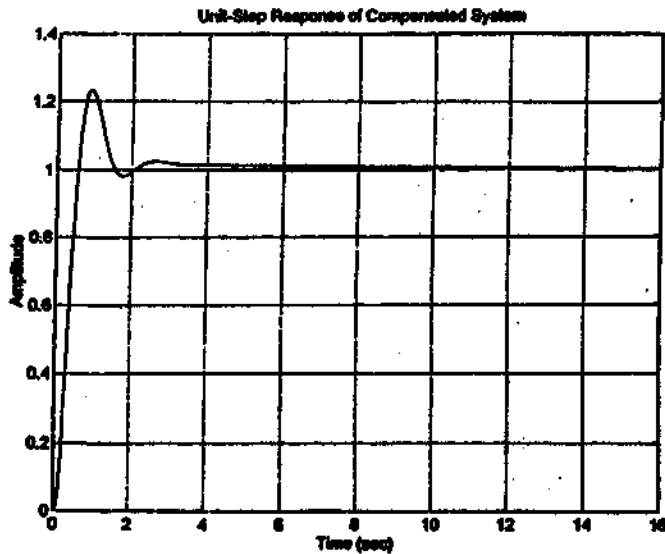

**B-7-14.** The system needs at least one integrator to eliminate offset in the step response. Therefore, the controller should include an open-loop pole at the origin. Suppose that we want to have the dominant closed-loop poles around  $s = -2 \pm j2\sqrt{3}$ . Then, the angle deficiency becomes as follows:

$$\begin{aligned}
 \text{Angle deficiency} &= 180^\circ - 134.29424^\circ - 112.29253^\circ - 120^\circ \\
 &= -186.58677^\circ
 \end{aligned}$$

See the diagram shown to the right.

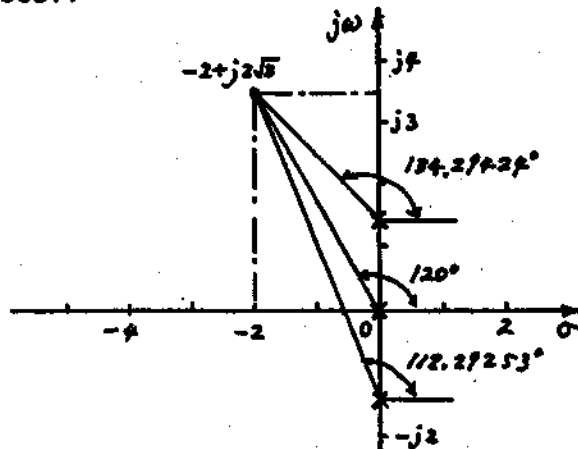

This suggests that the controller should have two zeros near point  $s = -2$ . Therefore, we choose the controller  $G_c(s)$  to have the following form:

$$G_c(s) = \frac{K(s+2)^2}{s}$$

(It is a PID controller.)

Let us plot a root-locus plot for this system. Note that

$$G_c(s)G(s) = \frac{K(s+2)^2}{s} \frac{10}{s^2+2} = \frac{10K(s^2+4s+4)}{s^2+2s}$$

The following MATLAB program will produce the root-locus plot as shown below.

```
% ***** Root-locus plot *****
num = [0 1 4 4];
den = [1 0 2 0];
rlocus(num,den)
v = [-8 2 -5 5]; axis(v); axis('square')
grid
title('Root-Locus Plot of Gc(s)G(s) = 10K(s^2+4s+4)/[s(s^2+2)]')
```

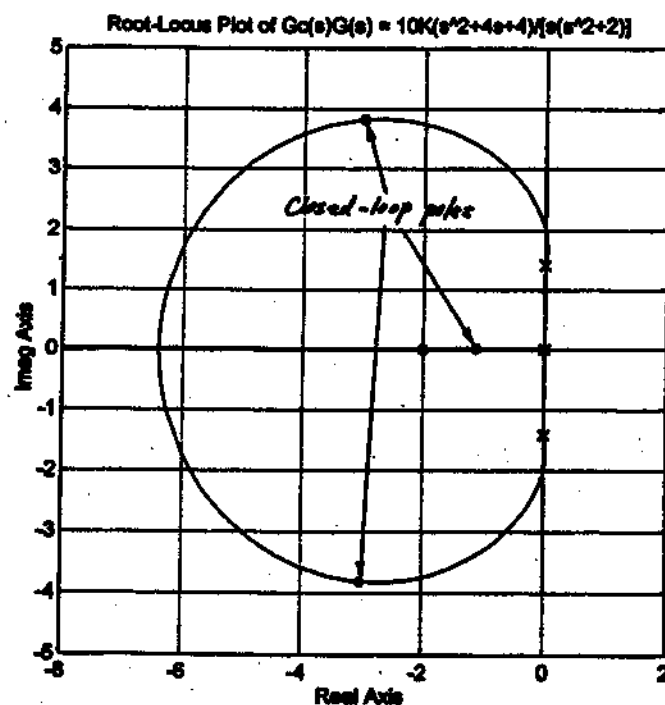

By examining this root-locus plot, it may be a good choice to have the dominant closed-loop poles at

$$s = -3 \pm j 3.8$$

(Of course, other points on the circular root locus may be chosen as potential dominant closed-loop poles.) The characteristic equation for this system is

$$s^3 + 2s + 10K(s^2 + 4s + 4) = 0$$

or

$$s^3 + 10Ks^2 + (2 + 40K)s + 40K = 0$$

By dividing this characteristic equation by the quadratic factor

$$(s + 3 + j 3.8)(s + 3 - j 3.8) = s^2 + 6s + 23.44$$

or

$$\begin{array}{r}
 s^2 + 6s + 23.44 \overline{) s^3 + 10Ks^2 + (2 + 40K)s + 40K} \\
 \underline{s^3 + 6s^2 + 23.44s} \phantom{+ 40K} \\
 (10K - 6)s^2 + (40K - 21.44)s + 40K \\
 \underline{(10K - 6)s^2 + (60K - 36)s + 234.44K - 140.64} \\
 0s \phantom{+} 0
 \end{array}$$

By setting the remainder equal to zero, we require

$$40K - 21.44 - 60K + 36 = 0 \tag{1}$$

$$40K - 234.44K + 140.64 = 0 \tag{2}$$

Equation (1) yields  $K = 0.728$  and Equation (2) gives  $K = 0.723$ . Hence, we may choose

$$K = 0.725$$

Then, the controller can be written as follows:

$$G_c(s) = 0.725 \frac{(s+2)^2}{s}$$

The open-loop transfer function becomes as

$$G_c(s)G(s) = \frac{0.725(s+2)^2}{s} \frac{10}{s^2+2} = \frac{7.25(s+2)^2}{s(s^2+2)}$$

The assumed closed-loop pole locations

$$s = -3 \pm j 3.8$$

will be slightly shifted. By substituting  $K = 0.725$  into the characteristic equation, we obtain

$$s^3 + 10ks^2 + (2 + 40k)s + 40k = s^2 + 7.25s^2 + 31s + 29 = 0$$

The roots of this characteristic equation can be obtained by use of MATLAB as follows:

```
p = [1 7.25 31 29];
roots(p)

ans =

-3.0106 + 3.8128i
-3.0106 - 3.8128i
-1.2287
```

These roots (closed-loop poles) are shown on the root-locus plot shown earlier.

Using the designed controller, the unit-step response and unit-ramp response can be obtained by use of MATLAB. The following MATLAB program will produce the unit-step response curve, as shown below.

```
% ***** Unit-step response *****
numc = [0 7.25 29 29];
denc = [1 7.25 31 29];
step(numc,denc)
grid
title('Unit-Step Response of Compensated System (Problem B-7-12)')
```

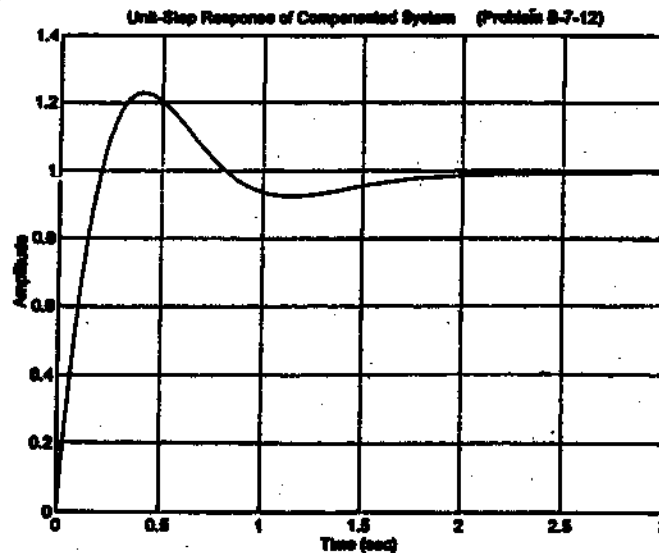

The response curve shows that the maximum overshoot is 23% and the settling time is 3 sec. Therefore, the system satisfies the given specifications.

The MATLAB program shown next produces a unit-ramp response curve.

```

% ***** Unit-ramp response *****
num1 = [0 0 7.25 29 29];
den1 = [1 7.25 31 29 0];
t = 0:0.02:3;
c = step(num1,den1,t);
plot(t,c,'-','t,t','-')
grid
title('Unit-Ramp Response of Compensated System (Problem B-7-12)')
xlabel('t Sec')
ylabel('Input Ramp and Output')

```

The resulting unit-ramp response curve is shown below.

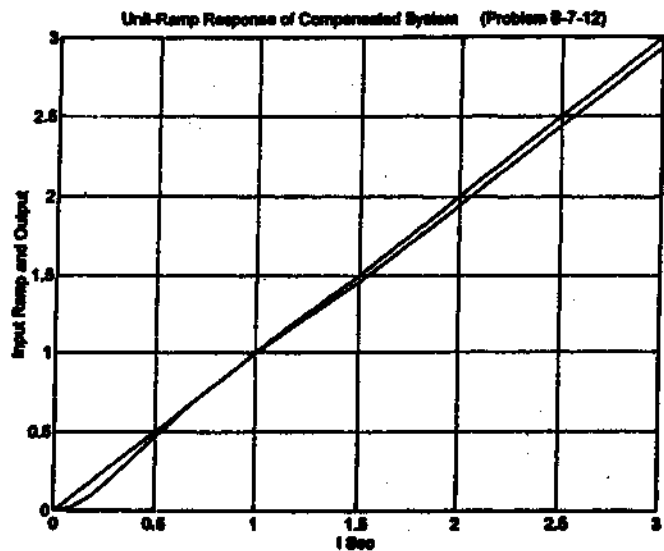

Since  $K_v$  of this system is

$$K_v = \lim_{s \rightarrow 0} s \frac{7.25 (s+2)^2}{s(s^2+2)} = 14.5$$

the steady-state error in the unit-ramp response is

$$e_{ss} = \frac{1}{K_v} = \frac{1}{14.5} = 0.06896$$

The designed controller is acceptable. (Note that infinitely many other controllers can be designed for this system. The present controller is just one of many possible controllers.)

**B-7-15.** Let us choose the dominant closed-loop poles at  $s = -2 \pm j2\sqrt{3}$ . Then, the angle deficiency at a closed-loop pole  $s = -2 + j2\sqrt{3}$  becomes as follows:

$$\begin{aligned}
 \text{Angle deficiency} &= 180^\circ - 120^\circ - 90^\circ - 106.1021^\circ + 113.4132^\circ \\
 &= -22.6889^\circ
 \end{aligned}$$

See the following diagram for the computation of the angle deficiency.

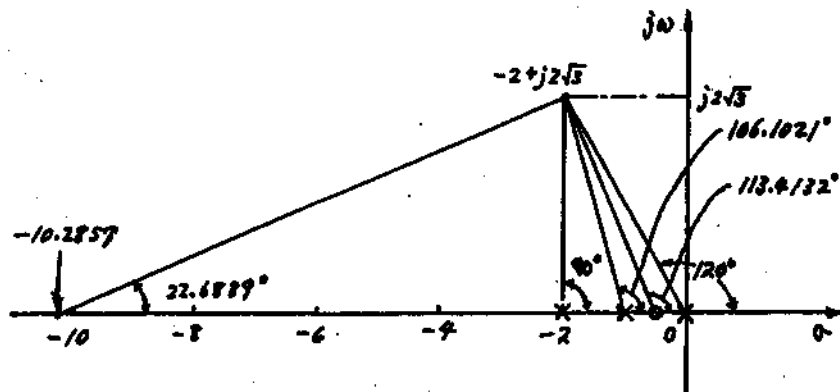

From this diagram we find the zero of the compensator to be at  $s = -10.2857$ . The compensator thus can be written as

$$G_c(s) = K(s + 10.2857)$$

The feedforward transfer function becomes

$$G_c(s)G(s) = \frac{K(s + 10.2857)(2s + 1)}{s(s + 1)(s + 2)}$$

The gain  $K$  can be determined from the magnitude condition:

$$\left| \frac{K(s + 10.2857)(2s + 1)}{s(s + 1)(s + 2)} \right|_{s = -2 + j2\sqrt{3}} = 1$$

or

$$K = \left| \frac{s(s + 1)(s + 2)}{(s + 10.2857)(2s + 1)} \right|_{s = -2 + j2\sqrt{3}}$$

The evaluation of this  $K$  can be made easily by use of MATLAB. The following MATLAB program produces the value of  $K$ .

The following

```

% ***** Determination of gain constant K *****
a = [1 3 2 0];
b = [2 21.5714 10.2857];
s = -2 + j*2*sqrt(3);
format long
K = abs(polyval(a,s))/abs(polyval(b,s))

K =

0.73684318666243
    
```

Hence, the compensator becomes as follows:

$$G_c(s) = 0.73684(s + 10.2857)$$

The closed-loop transfer function becomes as

$$\frac{C(s)}{R(s)} = \frac{1.47368s^2 + 15.89467s + 7.578915}{s^2 + 4.47368s^2 + 17.8947s + 7.578915}$$

The following MATLAB program will produce the unit-step response curve.

```
% ***** Unit-step response *****
numc = [0 1.47368 15.89467 7.578915];
denc = [1 4.47368 17.8947 7.578915];
t = 0:0.01:5;
c = step(numc,denc,t);
plot(t,c)
grid
title('Unit-Step Response of Compensated System (Problem B-7-13)')
xlabel('t Sec')
ylabel('Output')
```

The resulting unit-step response curve is shown below.

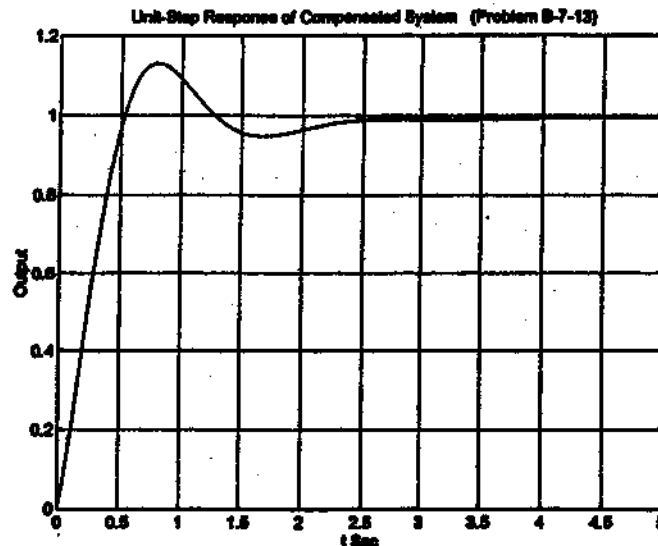

The response curve shows the maximum overshoot of 13% and the settling time of approximately 3 sec. Thus, the designed system satisfies the requirements of the problem.

**B-7-16.** The first step in the design of the compensator is to choose the desired closed-loop pole locations. Considering the open-loop poles of the plant and the given specifications, we may choose the dominant closed-loop poles to be

$$s = -4 \pm j4$$

(Of course, other choices can be made.) With the present choice of the dominant closed-loop poles, we may choose the compensator to have a zero at  $s = -4$

so that the plant pole at  $s = -4$  can be canceled. We may also include a zero at  $s = -1$ . Thus, we may choose the transfer function of the compensator to be

$$G_c(s) = K \frac{(s+4)(s+1)}{s+b}$$

where the compensator pole at  $s = -b$  need be determined based on the angle deficiency. The angle deficiency is

$$\text{Angle deficiency} = 180^\circ - 135^\circ - 135^\circ + 126.8699^\circ = 36.8699^\circ$$

The compensator pole must provide an angle of  $-36.8699^\circ$ . From the diagram given below we find  $b$  to be  $-9.3333$ .

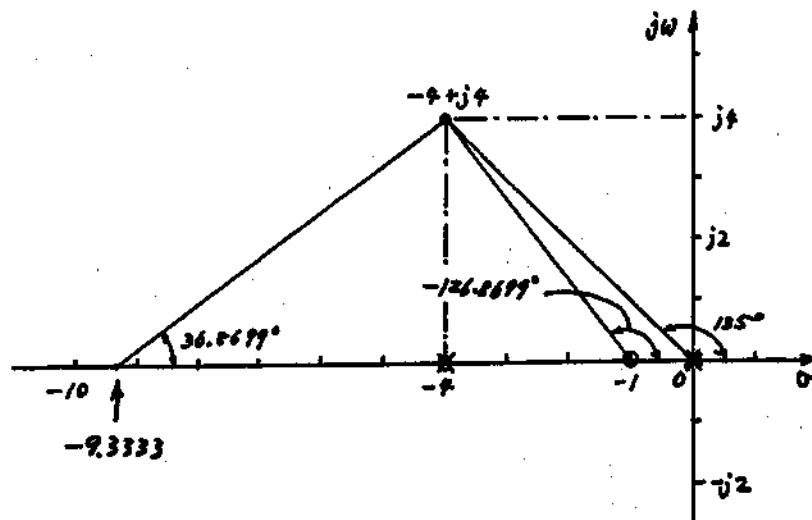

Then, the compensator  $G_c(s)$  can be given by

$$G_c(s) = K \frac{(s+4)(s+1)}{s+9.3333}$$

The open-loop transfer function becomes as follows:

$$G_c(s)G(s) = \frac{K(s+4)(s+1)}{(s+9.3333)s^2(s+4)} = \frac{K(s+1)}{s^2(s+9.3333)}$$

The value of gain  $K$  can be determined from the magnitude condition:

$$\left| \frac{K(s+1)}{s^2(s+9.3333)} \right|_{s=-4+j4} = 1$$

or

$$K = \left| \frac{s^2 + 9.3333s^2}{s+1} \right|_{s=-4+j4}$$

The value of gain  $K$  can be determined easily by use of MATLAB. See the following MATLAB program:

```

% ***** Determination of gain K *****
a = [1 9.3333 0 0];
b = [1 1];
s = -4+j*4;
K = abs(polyval(a,s))/abs(polyval(b,s))

K =
42.6665

```

Hence, the compensator becomes as follows:

$$G_c(s) = 42.6665 \frac{(s+4)(s+1)}{s+9.3333}$$

The closed-loop transfer function of the designed system becomes as

$$\frac{C(s)}{R(s)} = \frac{42.6665s + 22.6665}{s^3 + 9.3333s^2 + 42.6665s + 42.6665}$$

The following MATLAB program produces the unit-step response curve, which is shown below.

```

% ***** Unit-step response *****
numc = [0 0 42.6665 42.6665];
denc = [1 9.3333 42.6665 42.6665];
step(numc,denc)
grid
title('Unit-Step Response of Compensated System (Problem B-7-16)')

```

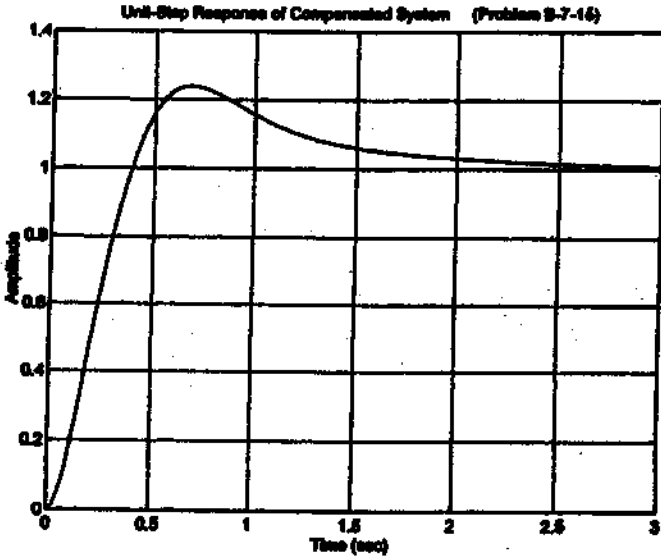

The closed-loop poles are located at  $s = -4 \pm j4$  and  $s = -1.3333$  as seen from the following MATLAB output.

```

roots(denc)
ans =
-4.0000 + 4.0000i
-4.0000 - 4.0000i
-1.3333
    
```

The unit-step response curve shows that the maximum overshoot is approximately 25% and the settling time is approximately 3 sec. Hence, the given specifications are met and the designed system is acceptable.

**B-7-17.** The closed-loop transfer function for the system is

$$\frac{C(s)}{R(s)} = \frac{K}{2s^2 + s + KK_h s + K} = \frac{\frac{K}{2}}{s^2 + \frac{1+KK_h}{2}s + \frac{K}{2}}$$

From this equation, we obtain

$$\omega_n = \sqrt{\frac{K}{2}}, \quad 2\zeta\omega_n = \frac{1+KK_h}{2}$$

Since the damping ratio  $\zeta$  is specified as 0.5, we get

$$\omega_n = \frac{1+KK_h}{2}$$

Therefore, we have

$$\frac{1+KK_h}{2} = \sqrt{\frac{K}{2}}$$

The settling time is specified as

$$t_s = \frac{4}{\zeta\omega_n} = \frac{4}{(1+KK_h)/4} = \frac{16}{1+KK_h} \leq 2$$

Since the feedforward transfer function  $G(s)$  is

$$G(s) = \frac{\frac{K}{2s+1}}{1 + \frac{KK_h}{2s+1}} \cdot \frac{1}{s} = \frac{K}{2s+1+KK_h} \cdot \frac{1}{s}$$

the static velocity error constant  $K_v$  is

$$K_v = \lim_{s \rightarrow 0} s G(s) = \lim_{s \rightarrow 0} s \frac{K}{2s+1+KK_h} \cdot \frac{1}{s} = \frac{K}{1+KK_h}$$

This value must be equal to or greater than 50. Hence,

$$\frac{K}{1+KK_h} \geq 50$$

Thus, the conditions to be satisfied can be summarized as follows:

$$\frac{1+KK_h}{2} = \sqrt{\frac{K}{2}} \quad (1)$$

$$\frac{16}{1+KK_h} \leq 2 \quad (2)$$

$$\frac{K}{1+KK_h} \geq 50 \quad (3)$$

$$0 < K_h < 1$$

From Equations (1) and (2), we get

$$8 \leq 1+KK_h = \sqrt{2K}$$

or

$$32 < K$$

From Equation (3) we obtain

$$\frac{K}{50} \geq 1+KK_h = \sqrt{2K}$$

or

$$K \geq 5000$$

If we choose  $K = 5000$ , then we get

$$1+KK_h = \sqrt{2K} = 100$$

or

$$K_h = \frac{99}{5000} = 0.0198$$

Thus, we determined a set of values of  $K$  and  $K_h$  as follows:

$$K = 5000, \quad K_h = 0.0198$$

With these values of  $K$  and  $K_h$ , all specifications are satisfied.

---

B-7-18.

$$\frac{C(s)}{R(s)} = \frac{K}{s^2 + KK_h s + K}$$

Noting that

$$s^2 + KK_h s + K = (s + 1 + j\sqrt{3})(s + 1 - j\sqrt{3}) = s^2 + 2s + 4$$

we obtain  $KK_h = 2$  and  $K = 4$ . Hence,  $K_h = 0.5$ .

To plot a root-locus diagram for the system with  $K_h = 0.5$ , we need to rewrite the open-loop transfer function such that it contains a multiplying factor  $K$ . Since the characteristic equation for  $K_h = 0.5$  is

$$s^2 + 0.5Ks + K = 0$$

we rewrite this equation as

$$1 + \frac{K(0.5s+1)}{s^2} = 0$$

and consider  $K(0.5s + 1)/s^2$  as the open-loop transfer function, or

$$G(s) = \frac{K(0.5s+1)}{s^2}$$

Thus, the system will have an open-loop zero. (This zero is not a closed-loop zero.) A MATLAB program to obtain the root-locus plot is shown below. The resulting root-locus plot is also shown below.

```
% ***** Root-locus plot *****
```

```
num = [0 0.5 1];
den = [1 0 0];
rlocus(num,den)
v = [-5 1 -3 3]; axis(v); axis('square')
grid
title('Root-Locus Plot')
```

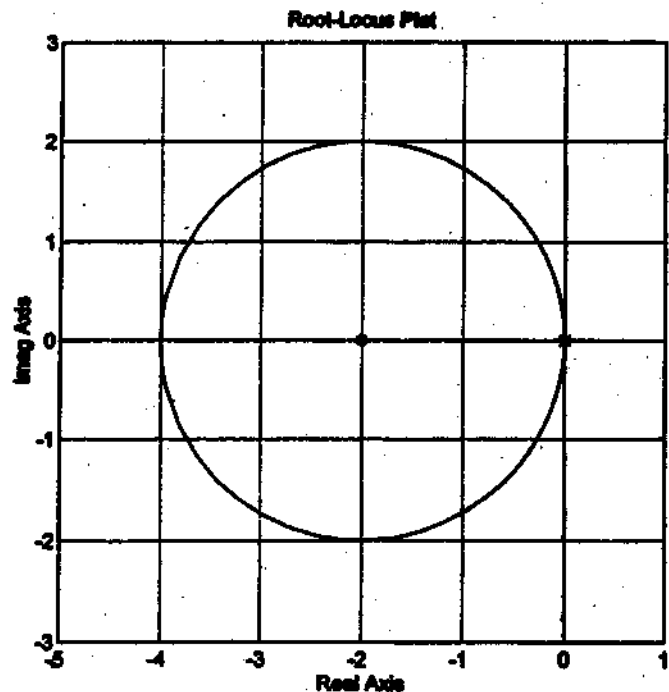

**B-7-19.** The closed-loop transfer function is

$$\frac{C(s)}{R(s)} = \frac{K}{s[(s+1)(s+2) + 0.2K] + K} = \frac{K}{s^3 + 3s^2 + 2s + 0.2Ks + K}$$

The dominant closed-loop poles may be written as

$$s = x \pm j\sqrt{3}x$$

Substituting  $s = x + j\sqrt{3}x$  into the characteristic equation, we obtain

$$(x+j\sqrt{3}x)^3 + 3(x+j\sqrt{3}x)^2 + 2(x+j\sqrt{3}x) + 0.2K(x+j\sqrt{3}x) + K = 0$$

or

$$-8x^3 - 6x^2 + 2x + 0.2Kx + K + 2\sqrt{3}j(3x^2 + x + 0.1Kx) = 0$$

By equating the real part and imaginary part to zero, respectively, we obtain

$$-8x^3 - 6x^2 + 2x + 0.2Kx + K = 0 \quad (1)$$

$$3x^2 + x + 0.1Kx = 0 \quad (2)$$

From equation (2), noting that  $x \neq 0$ , we get

$$3x + 1 + 0.1K = 0$$

or

$$K = -10(3x + 1)$$

By substituting this equation into Equation (1), we obtain

$$8x^3 + 12x^2 + 30x + 10 = 0$$

To find the roots of this cubic equation, we may enter the following MATLAB program into the computer:

```
p = [8 12 30 10];
roots(p)

ans =

-0.5622 + 1.7354i
-0.5622 - 1.7354i
-0.3756
```

The value of  $x$  must be real. Hence, we take  $x = -0.3756$ . Thus, the dominant closed-loop poles are located at

$$s = -0.3756 \pm j0.6506$$

The value of  $K$  for the dominant closed-loop poles is obtained as

$$\begin{aligned} K &= -10(3x + 1) \\ &= -10(-3 \times 0.3756 + 1) = 1.268 \end{aligned}$$

To obtain the unit-step response of this system, we first substitute  $K = 1.268$  into the closed-loop transfer function and then enter the following MATLAB program into the computer:

```
% ***** Unit-step response *****
```

```
num = [0 0 0 1.268];
```

```
den = [1 3 2.2536 1.268];
```

```
t = 0:0.05:20;
```

```
c = step(num,den,t);
```

```
plot(t,c)
```

```
grid
```

```
title('Unit-Step Response (Problem B-7-19)')
```

```
xlabel('t Sec')
```

```
ylabel('Output c(t)')
```

The resulting unit-step response curve is shown below.

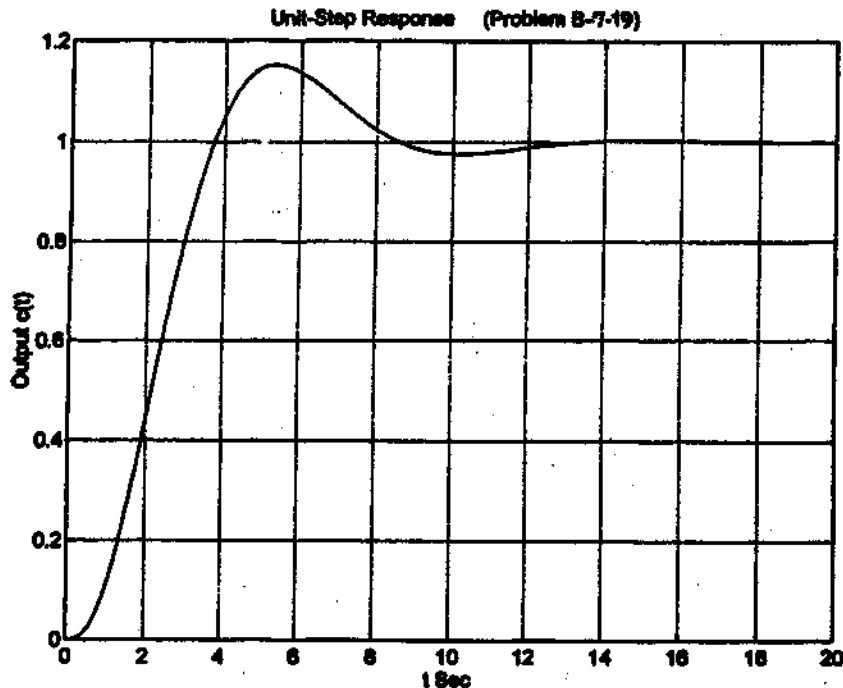

B-7-20. The characteristic equation is

$$(s+\alpha) \frac{2}{s^2(s+2)} + 1 = 0$$

In this case the variable  $\alpha$  is not a multiplying factor. Hence, we need to rewrite the characteristic equation such that  $\alpha$  becomes a multiplying factor. Since the characteristic equation is

$$s^3 + 2s^2 + 2s + 2\alpha = 0$$

we rewrite it as follows:

$$1 + \frac{2\alpha}{s^3 + 2s^2 + 2s} = 0$$

Define  $K = \alpha$ . Then, the characteristic equation becomes

$$1 + \frac{2K}{s(s^2 + 2s + 2)} = 0$$

A root-locus plot of this system may be obtained by entering the following MATLAB program into the computer. The resulting root-locus plot is shown below.

```

% ***** Root-locus plot *****

num = [0 0 0 2];
den = [1 2 2 0];
K1 = 0:0.1:10; K2 = 10:0.5:200;
K = [K1 K2];
r = rlocus(num,den,K);
plot(r,'-')
hold
Current plot held
x = [0 -2]; y = [0 3.464]; line(x,y)
v = [-3 1 -2 2]; axis(v); axis('square')
grid
title('Root-Locus Plot')
xlabel('Real Axis');
ylabel('Imag Axis')

```

From the root-locus plot, the dominant closed-loop poles that correspond to the damping ratio  $\zeta$  of 0.5 are found to be

$$s = -0.5 \pm j0.866$$

The value of K corresponding to the dominant closed-loop poles is obtained as

$$K = \left| \frac{s(s^2 + 2s + 2)}{2} \right|_{s = -0.5 + j0.866} = 0.5$$

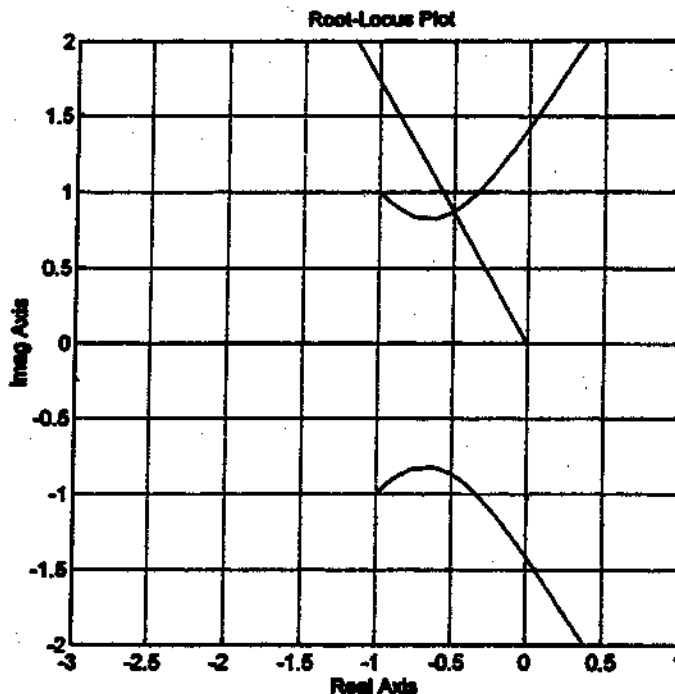

**B-7-21.** The closed-loop transfer function is

$$\frac{C(s)}{R(s)} = \frac{\left(\frac{s+1.4}{s+5}\right) \frac{10(s+10)}{s(s+1)(s+10)+10ks}}{1 + \left(\frac{s+1.4}{s+5}\right) \frac{10(s+10)}{s(s+1)(s+10)+10ks}}$$

Thus, the characteristic equation is

$$1 + \left(\frac{s+1.4}{s+5}\right) \frac{10(s+10)}{s(s+1)(s+10)+10ks} = 0$$

Since the variable  $k$  is not a multiplying factor, we rewrite the characteristic equation as

$$(s+5)s(s+1)(s+10) + (s+5)10ks + (s+1.4)10(s+10) = 0$$

which may be rewritten as

$$1 + \frac{10(s+5)ks}{(s+10)(s^3+6s^2+15s+14)} = 0$$

or

$$1 + \frac{10(s+5)ks}{(s+2)(s+10)(s+2+j1.732)(s+2-j1.732)} = 0$$

Notice that the open-loop poles are at  $s = -2$ ,  $s = -10$ , and  $s = -2 \pm j1.732$ . A root locus plot for the system may be obtained by entering the following **MATLAB** program into the computer. The resulting root-locus plot is shown on the next page.

```
% ***** Root-locus plot *****
num = [0 0 10 50 0];
den = [1 18 75 164 140];
numa = [0 0 10];
dena = [1 11 20];
rlocus(num,den)
hold
Current plot held
s = rlocus(numa,dena);
plot(s, '-')
v = [-15 5 -10 10]; axis(v); axis('square')
x = [0 -5.5]; y = [0 9.5263]; line(x,y)
grid
title('Root-Locus Plot')
text(-12,3,'Asymptote')
```

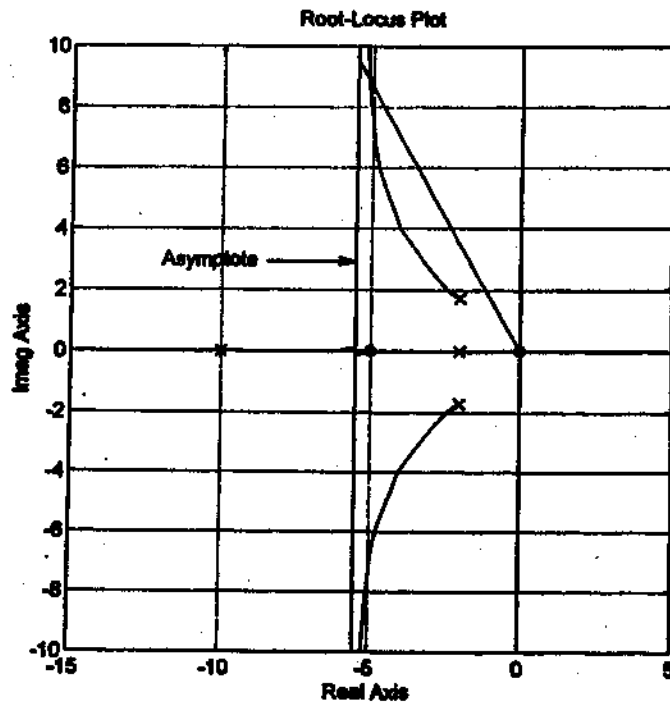

The dominant closed-loop poles having the damping ratio equal to 0.5 can be determined as the intersections of the root-locus branches and the straight lines from the origin having an angle of  $60^\circ$  or  $-60^\circ$  with the negative real axis. The intersections are located at  $s = -5.14 \pm j8.90$ . The gain value  $k$  is obtained from

$$k = \left| \frac{(s+2)(s+10)(s+2+j1.732)(s+2-j1.732)}{10(s+5)s} \right|_{s=-5.14 \pm j8.90}$$

$$= 9.08$$

With  $k = 9.08$ ,  $G(s)H(s)$  can be given as

$$G(s)H(s) = \left( \frac{s+1.4}{s+5} \right) \frac{10(s+10)}{s(s+1)(s+10) + 90.8s}$$

The static velocity error constant  $K_v$  is

$$K_v = \lim_{s \rightarrow 0} s G(s)H(s)$$

$$= \lim_{s \rightarrow 0} s \left( \frac{s+1.4}{s+5} \right) \frac{10(s+10)}{s[(s+1)(s+10) + 90.8]}$$

$$= 0.2778$$

**B-7-22.** The closed-loop transfer function of the system is

$$\frac{C(s)}{R(s)} = \frac{K}{s^2 + (1 + KK_h)s + K}$$

The characteristic equation for the system is

$$s^2 + s + K(K_h s + 1) = 0$$

Divide this characteristic equation by  $s^2 + s$  and define

$$G(s) = \frac{K(K_h s + 1)}{s^2 + s}$$

Note that  $G(s)$  is in the form suitable for plotting the root loci.

Root-locus plots for  $G(s)$  when  $K_h = 0.1$ ,  $K_h = 0.3$ , and  $K_h = 0.5$  are shown in Figures (a), (b), and (c), respectively.

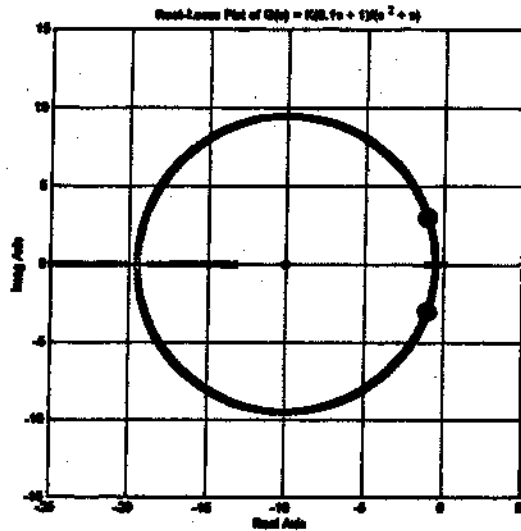

(a)

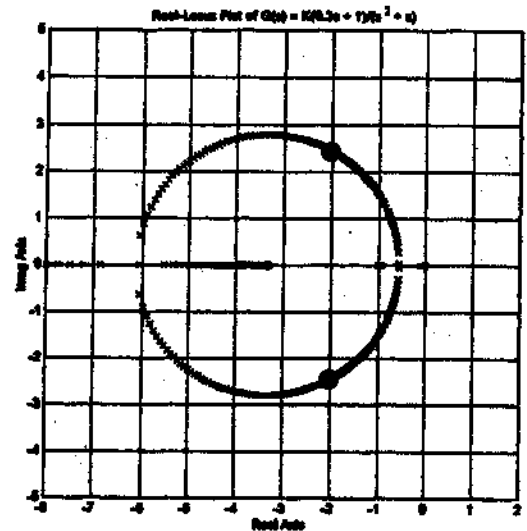

(b)

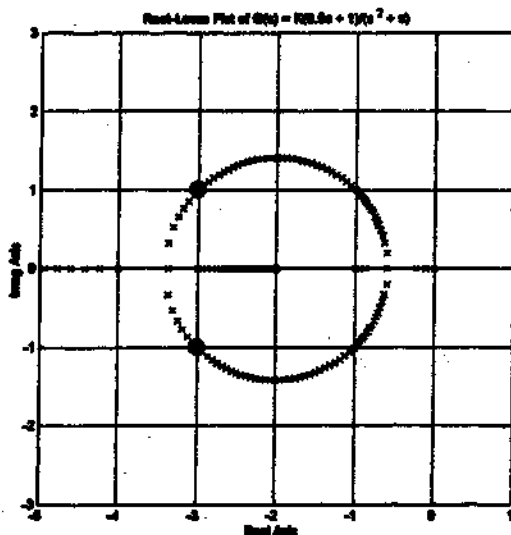

(c)

The closed-loop poles when  $K = 10$ ,  $K_h = 0.1$ ;  $K = 10$ ,  $K_h = 0.3$ ;  $K = 10$ ,  $K_h = 0.5$  are shown by ● in Figures (a), (b), (c), respectively.

The closed-loop transfer function when  $K = 10$  and  $K_h = 0.1$  becomes as follows:

$$\frac{C(s)}{R(s)} = \frac{10}{s^2 + 2s + 10}$$

The two closed-loop poles are

$$s = -1 \pm j3$$

The closed-loop transfer function  $K = 10$  and  $K_h = 0.3$  is

$$\frac{C(s)}{R(s)} = \frac{10}{s^2 + 4s + 10}$$

The closed-loop poles are located at

$$s = -2 \pm j\sqrt{6}$$

Similarly, the closed-loop transfer function when  $K = 10$  and  $K_h = 0.5$  is

$$\frac{C(s)}{R(s)} = \frac{10}{s^2 + 6s + 10}$$

The closed-loop poles are located at

$$s = -3 \pm j$$

The unit-step response curves for the above three systems are shown in the figure shown below.

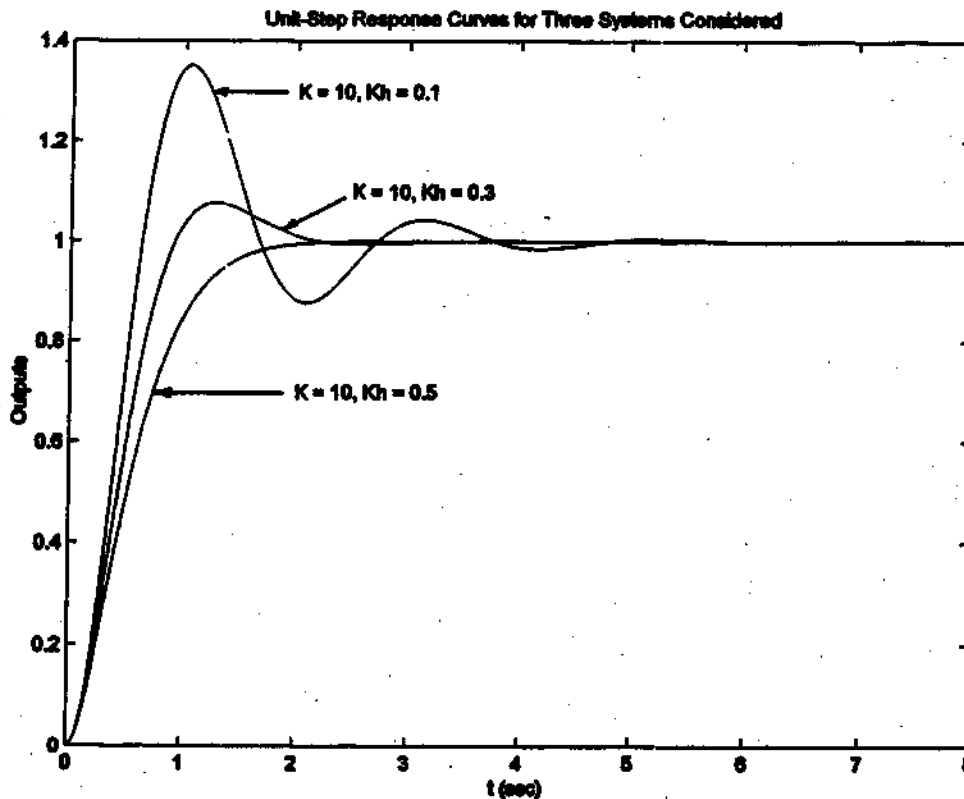

# CHAPTER 8

**B-8-1.** The closed-loop transfer function is

$$\frac{C(s)}{R(s)} = \frac{10}{s+11}$$

The steady-state outputs of the system when it is subjected to the given inputs are

(a)  $C_{ss}(t) = 0.905 \sin(t + 24.8^\circ)$

(b)  $C_{ss}(t) = 1.79 \cos(2t - 55.3^\circ)$

(c)  $C_{ss}(t) = 0.905 \sin(t + 24.8^\circ) - 1.79 \cos(2t - 55.3^\circ)$

**B-8-2.** The steady-state output  $c_{ss}(t)$  is

$$c_{ss}(t) = RK \sqrt{\frac{1+T_2^2\omega^2}{1+T_1^2\omega^2}} \sin(\omega t + \tan^{-1} T_2\omega - \tan^{-1} T_1\omega)$$

**B-8-3.**

Bode Diagram of  $G(s) = (1+s)/(1+2s)$

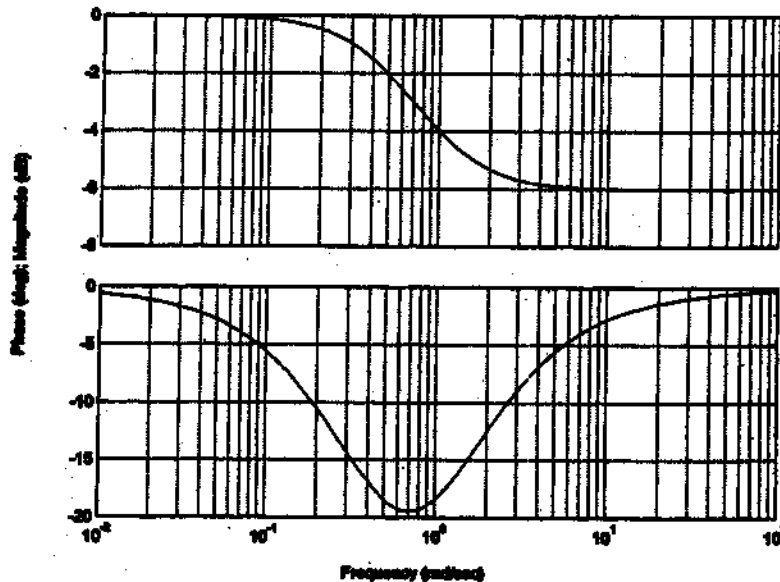

Bode Diagram of  $G_2(s) = (1 - s)/(1 + 2s)$

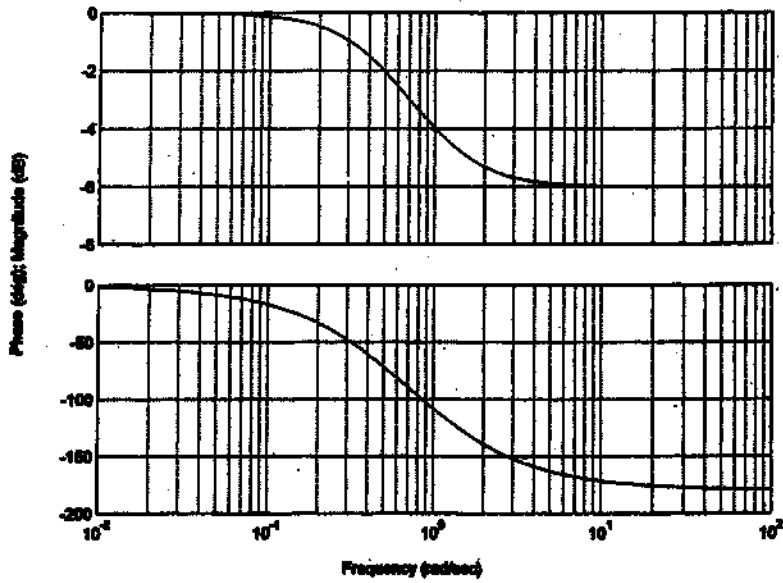

B-8-4.

$$G(s) = \frac{T_1 s + 1}{T_2 s + 1}$$

$(T_1 > T_2 > 0)$

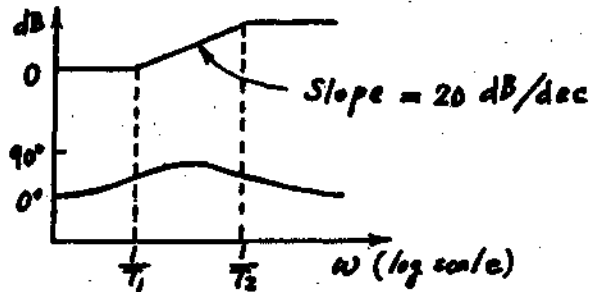

$$G(s) = \frac{T_1 s - 1}{T_2 s + 1}$$

$(T_1 > T_2 > 0)$

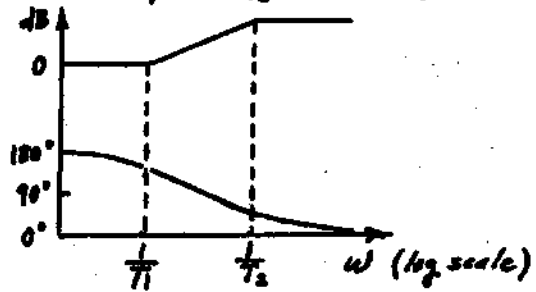

$$G(s) = \frac{-T_1 s + 1}{T_2 s + 1}$$

$(T_1 > T_2 > 0)$

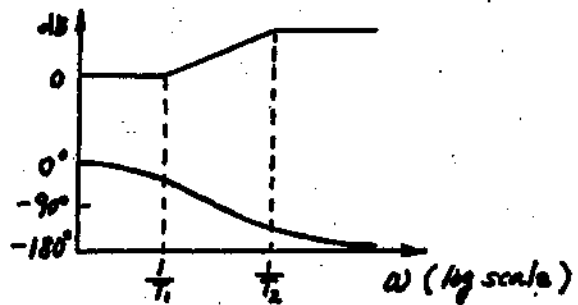

B-8-5. The following MATLAB program produces the Bode diagram shown below.

```

% ***** Bode diagram *****

num = [0 10 4 10];
den = [1 0.8 9 0];
bode(num,den)
title('Bode Diagram of G(s) = 10(s^2+0.4s+1)/(s^2+0.8s+9)')
    
```

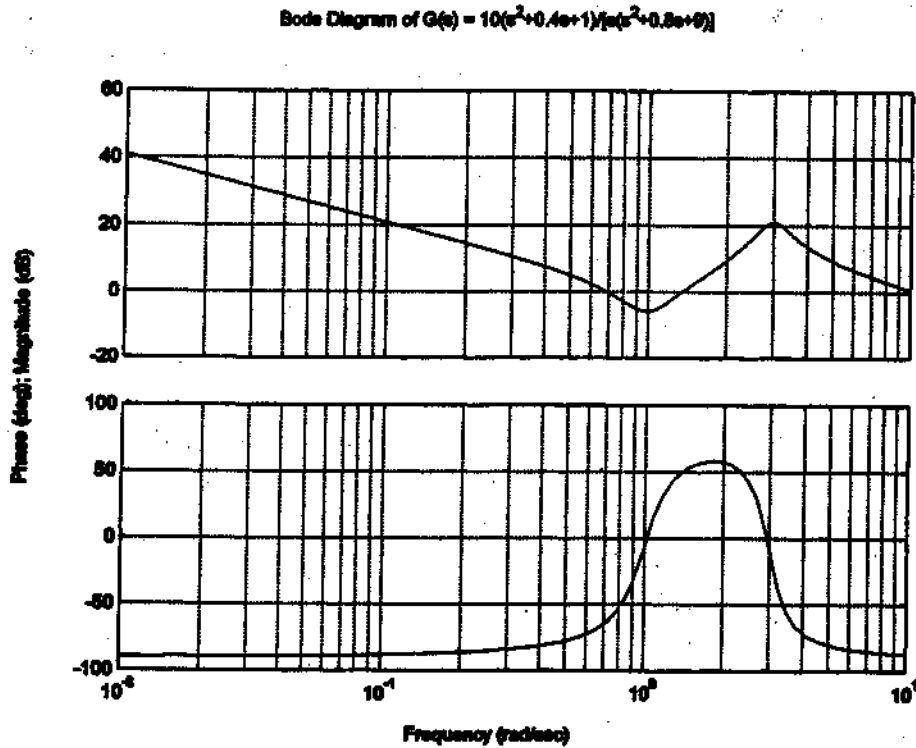

B-8-6. Noting that

$$G(j\omega) = \frac{\omega_n^2}{(j\omega)^2 + 2\zeta\omega_n(j\omega) + \omega_n^2} = \frac{1}{\left(j\frac{\omega}{\omega_n}\right)^2 + 2\zeta\left(j\frac{\omega}{\omega_n}\right) + 1}$$

we have

$$|G(j\omega_n)| = \left| \frac{1}{-1 + 2\zeta j + 1} \right| = \frac{1}{2\zeta}$$

B-8-7.

$$G(s) = \frac{s+0.5}{s^3+s^2+1}$$

The following MATLAB program produces the Bode diagram of  $G(s)$  shown below. Notice that the phase curve starts from  $0^\circ$  and ends at  $180^\circ$ .

```
% ***** Bode Diagram *****  
num = [0 0 1 0.5];  
den = [1 1 0 1];  
bode(num,den)  
title('Bode Diagram of G(s) = (s+0.5)/(s^3+s^2+1)')
```

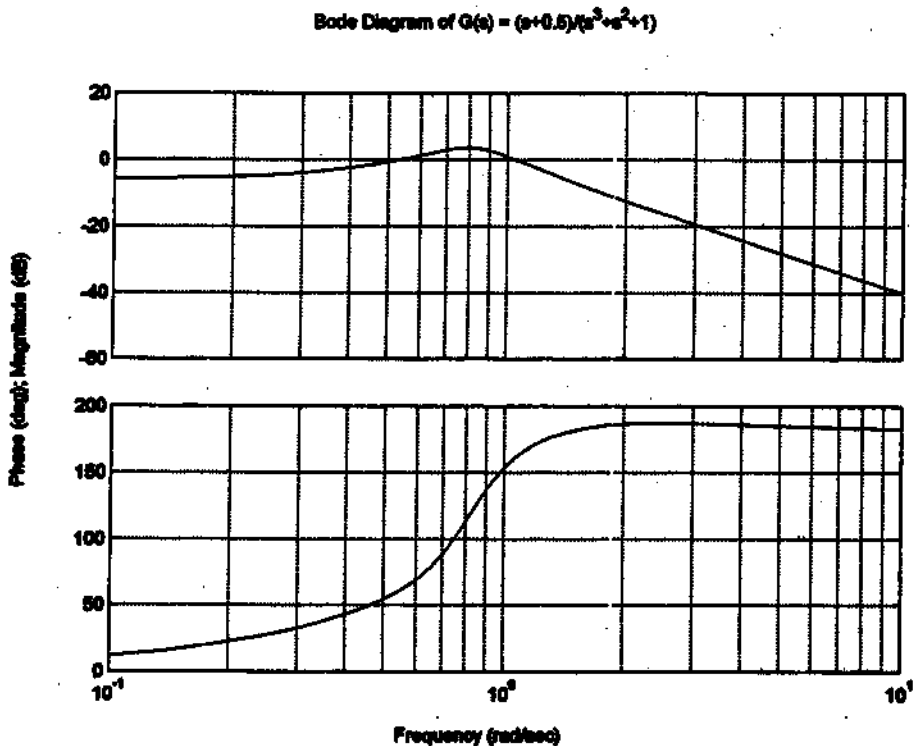

To verify why the phase angle starts from  $0^\circ$  and ends at  $180^\circ$ , we may compute angles  $\angle G(j0)$  and  $\angle G(j\infty)$ . Since

$$G(s) = \frac{s+0.5}{(s+1.4656)(s-0.2328-j0.7926)(s-0.2328+j0.7926)}$$

we have

$$\begin{aligned} \angle G(j0) &= \angle 0.5 - \angle 1.4656 - \angle -0.2328 - j0.7926 - \angle -0.2328 + j0.7926 \\ &= 0^\circ - 0^\circ - \tan^{-1} \frac{0.7926}{0.2328} + \tan^{-1} \frac{0.7926}{0.2328} = 0^\circ \end{aligned}$$

and

$$\begin{aligned} \angle G(j\omega) &= 90^\circ - 90^\circ - \tan^{-1} \frac{\infty}{-0.2328} - \tan^{-1} \frac{\infty}{-0.2328} \\ &= 90^\circ - 90^\circ + 90^\circ + 90^\circ = 180^\circ \end{aligned}$$

B-8-8. Typical Nyquist curves for the cases (a) and (b) are shown below.

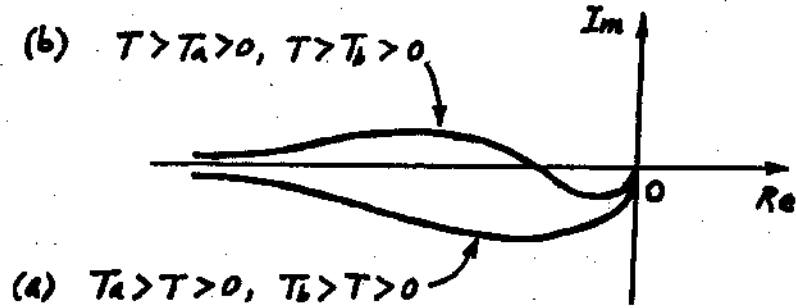

Nyquist plots of example systems that belong to case (a) and case (b) are shown below.

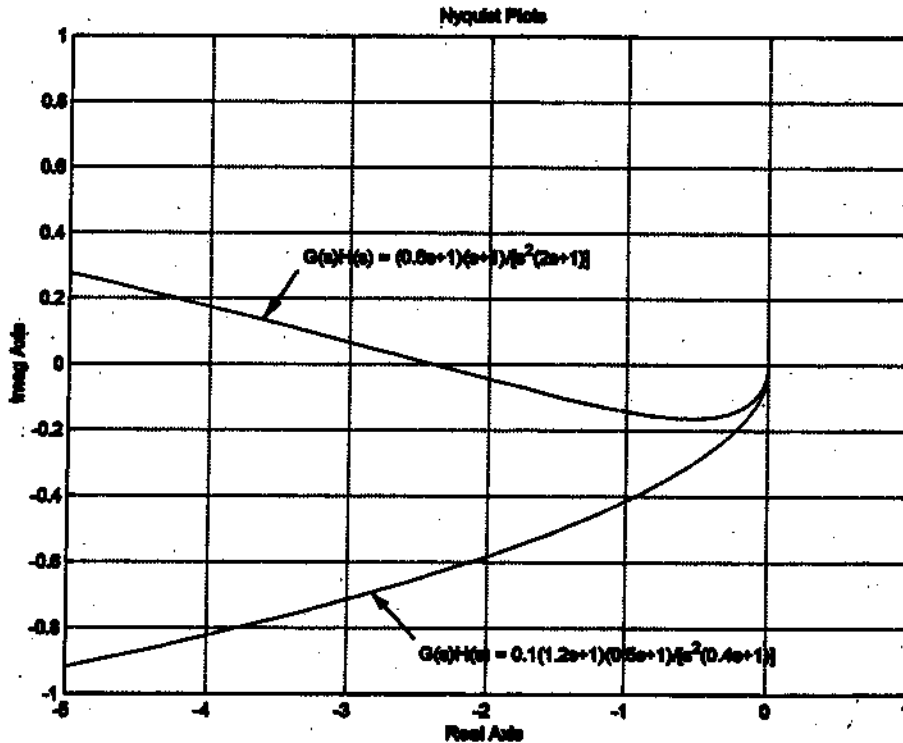

B-8-9.

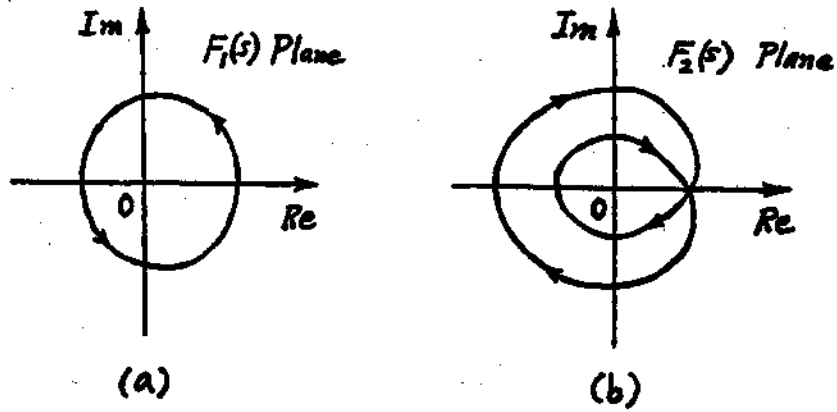

B-8-10.

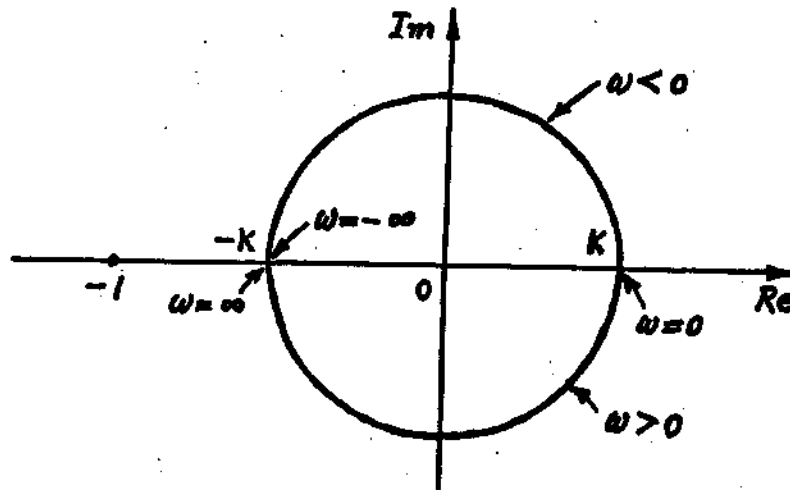

The stability requirement of the unity feedback control system with

$$G(j\omega) = \frac{K(1-j\omega)}{j\omega + 1}$$

is that  $-K$  be greater than  $-1$ , or

$$K < 1$$

Since we assume that  $K > 0$ , the condition for stability is

$$1 > K > 0$$

B-8-11. A closed-loop system with the following open-loop transfer function

$$G(s)H(s) = \frac{K}{s^2(T_1s + 1)} \quad (T_1 > 0)$$

is unstable, while a closed-loop system with the following open-loop transfer function is stable.

$$G(s)H(s) = \frac{K(T_2s+1)}{s^2(T_1s+1)} \quad (T_2 > T_1 > 0)$$

Nyquist plots of these two systems are shown below.

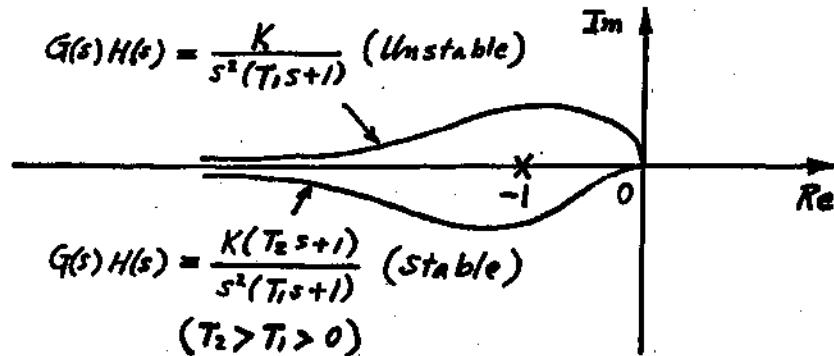

B-8-12.

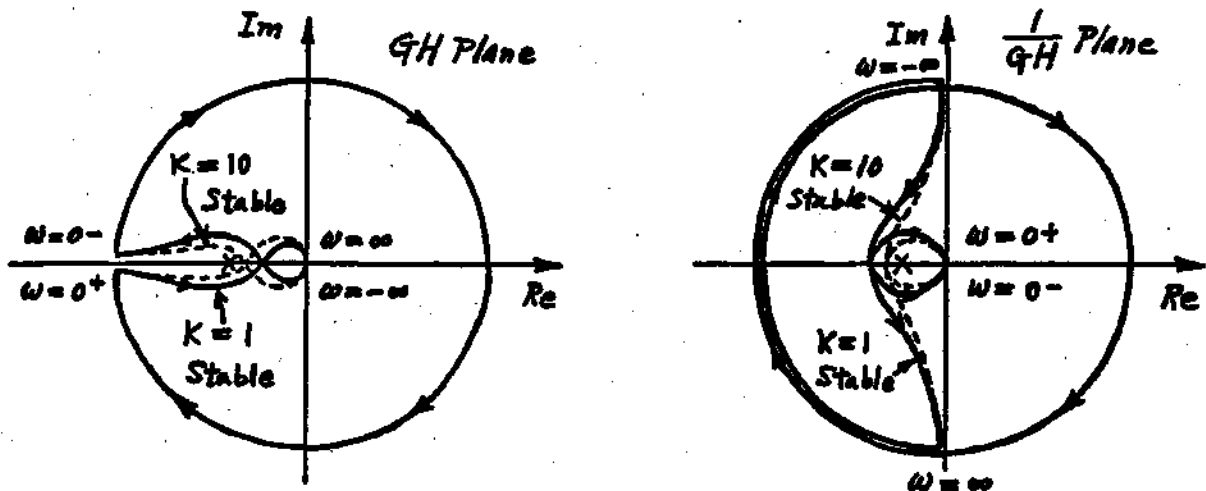

The system is stable for  $0 < K < 16.8$ .

B-8-13.

$$G(j\omega)H(j\omega) = \frac{K e^{-2j\omega}}{j\omega}$$

$$\begin{aligned} \angle G(j\omega)H(j\omega) &= \angle \cos 2\omega - j \sin 2\omega - 90^\circ \\ &= -2\omega - 90^\circ \end{aligned}$$

The phase angle becomes equal to  $-180^\circ$  at  $2\omega = \pi/2$  rad/sec. For stability, the magnitude  $|G(j\omega)H(j\omega)|$  at  $\omega = \pi/4$  must be less than unity. Hence, noting that

$$|G(j\omega)H(j\omega)| = \frac{K}{\omega}$$

we require that  $K < \pi/4$  for stability.

**B-8-14.** The following MATLAB program will produce the Nyquist plot shown below.

```

% ***** Nyquist plot *****
num = [0 0 0 1];
den = [1 0.8 1 0];
nyquist(num,den)
v = [-4 4 -4 4]; axis(v); axis('square')
grid
title('Nyquist Plot of G(s) = 1/[s(s^2+0.8s+1)]')

```

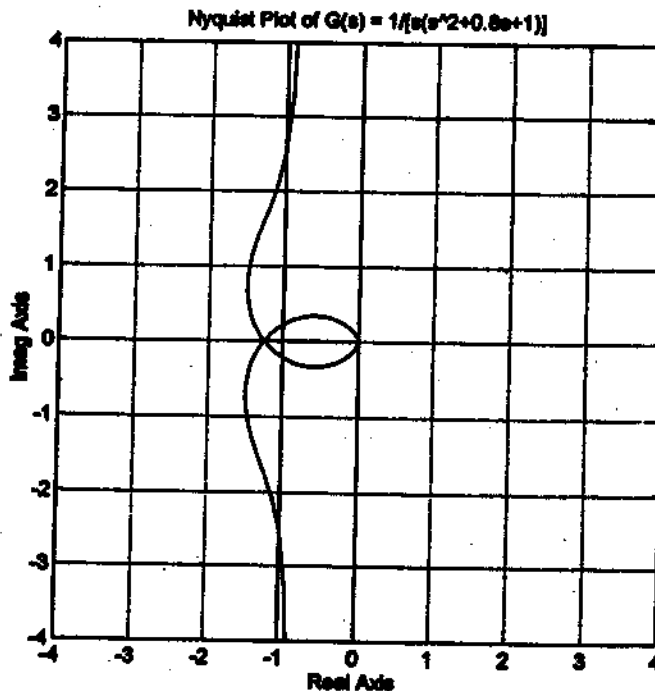

**B-8-15.** Note that  $G(s)$  has two open-loop poles in the right-half  $s$  plane, as seen from the following MATLAB output.

```

p = [1 0.2 1 1];
roots(p)

ans =

    0.2623 + 1.1451i
    0.2623 - 1.1451i
   -0.7246

```

The following MATLAB program produces the Nyquist plot shown below.

```
% ***** Nyquist plot *****
num = [0 0 0 1];
den = [1 0.2 1 1];
nyquist(num,den)
v = [-1.5 1.5 -1.5 1.5]; axis(v); axis('square')
grid
title('Nyquist Plot of G(s) = 1/[s^3+0.2s^2+s+1]')
```

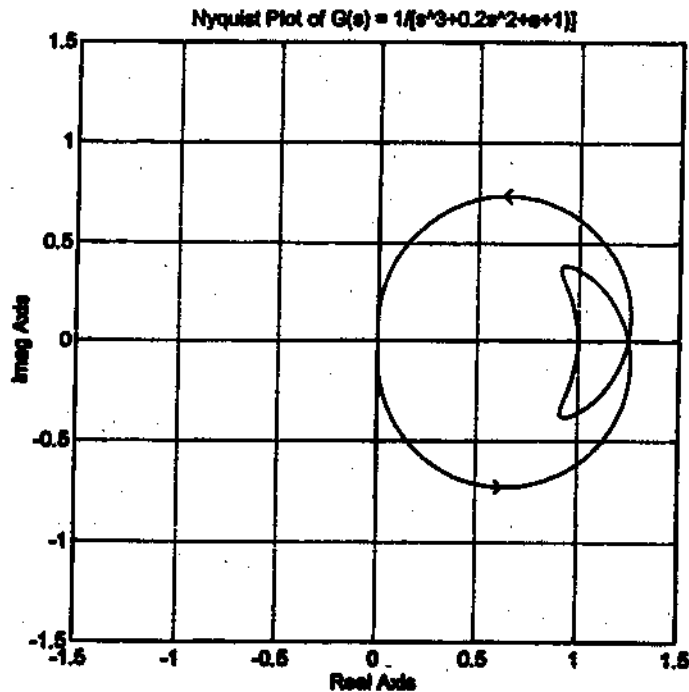

From the plot notice that the critical point  $(-1+j0)$  is not encircled. Because there are two open-loop poles in the right-half  $s$  plane and no encirclement of the critical point, the closed-loop system is unstable.

**B-8-16.** The following MATLAB program produces the Nyquist plot shown on the next page.

```
% ***** Nyquist plot *****
num = [0 1 2 1];
den = [1 0.2 1 1];
nyquist(num,den)
grid
title('Nyquist Plot of G(s) = (s^2+2s+1)/(s^3+0.2s^2+s+1)')
```

Since  $G(s)$  has two open-loop poles in the right-half  $s$  plane (see the solution to Problem B-8-15) and the Nyquist plot encircles the critical point  $(-1+j0)$

twice counterclockwise, the system is stable.

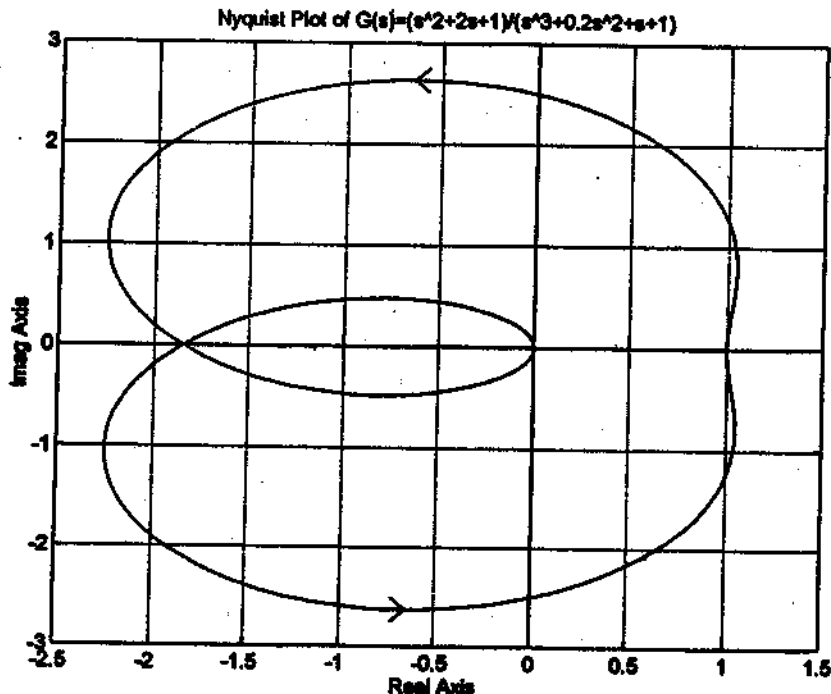

**B-8-17.** The open-loop transfer function is

$$G(s) = \frac{1}{s(s-1)}$$

The points corresponding to  $s = j0+$  and  $s = j0-$  on the locus of  $G(s)$  in the  $G(s)$  plane are  $j\infty$  and  $-j\infty$ , respectively. On the semicircular path with radius  $\epsilon$  (where  $\epsilon \ll 1$ ), the complex variable  $s$  can be written as

$$s = \epsilon e^{j\theta}$$

where  $\theta$  varies from  $-90^\circ$  to  $+90^\circ$ . Then  $G(s)$  becomes

$$G(\epsilon e^{j\theta}) = -\frac{1}{\epsilon e^{j\theta}} = \frac{1}{\epsilon} e^{-j(\theta + 180^\circ)}$$

The value  $1/\epsilon$  approaches infinity as  $\epsilon$  approaches zero, and  $-\theta$  varies from  $-90^\circ$  to  $-270^\circ$  as a representative point  $s$  moves along the semicircle in the  $s$  plane. Thus the points  $G(j0-) = -j\infty$  and  $G(j0+) = +j\infty$  are joined by a semicircle of infinite radius in the left-half  $G$  plane. The infinitesimal semicircular detour around the origin in the  $s$  plane maps into the  $G$  plane as a semicircle of infinite radius. Figure (a) shows the  $G(s)$  locus in the  $G$  plane. [Figure (a) is shown on the next page.]

Since  $G(s)$  has one pole in the right-half  $s$  plane ( $P = 1$ ) and  $G(s)$  locus encircles the  $-1 + j0$  point once clockwise ( $N = 1$ ), we have

$$Z = N + P = 2$$

There are two zeros of  $1 + G(s)$  in the right-half  $s$  plane. Therefore, the system is unstable.

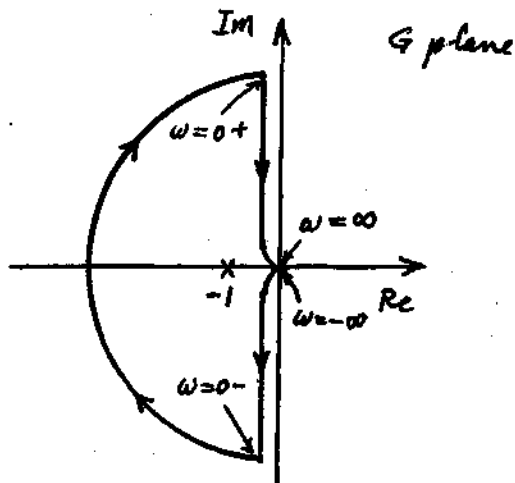
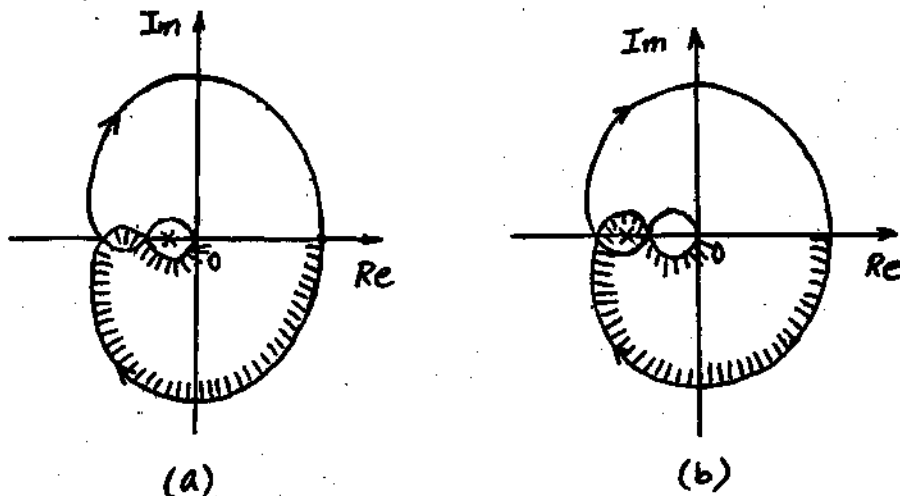

Figure (a)

**B-8-18.** Since  $G(s)$  has no poles in the right-half  $s$  plane, the stability of the system can be studied by checking the enclosure of the  $-1 + j0$  point by the Nyquist locus for  $0 < \omega < \infty$ .

If the Nyquist plot of  $G(s)$  is as shown in Figure 8-119(a), then there is no enclosure of the  $-1 + j0$  point. [See Figure (a) below.] Hence, the system is stable.

For the case of the Nyquist plot shown in Figure 8-119(b), the  $-1 + j0$  point is enclosed by the Nyquist plot of  $G(j\omega)$  for  $0 < \omega < \infty$ . [See Figure (b) below.] Hence, the system is unstable.



**B-8-19.** Consider the case where  $G(s)$  has one pole in the right-half  $s$  plane. From the Nyquist plot of  $G(j\omega)$  shown on the next page, the  $-1 + j0$  point is encircled by the  $G(j\omega)$  locus once clockwise and once counterclockwise. Hence  $N = 0$ . Since  $G(s)$  has one pole in the right-half  $s$  plane, we have  $P = 1$ . Since

$$Z = N + P = 0 + 1 = 1$$

the system is unstable.

Next, consider the case where  $G(s)$  has no pole in the right-half  $s$  plane, but has one zero in the right-half  $s$  plane. The  $-1 + j0$  point is encircled by the  $G(j\omega)$  locus once clockwise and once counterclockwise. Hence,  $N = 0$ . Since  $G(s)$  has no poles in the right-half  $s$  plane, we have  $P = 0$ . Therefore,

$$Z = N + P = 0 + 0 = 0$$

The system is stable. (Note that the presence of a zero of  $G(s)$  in the right-half  $s$  plane does not affect the stability of the system.)

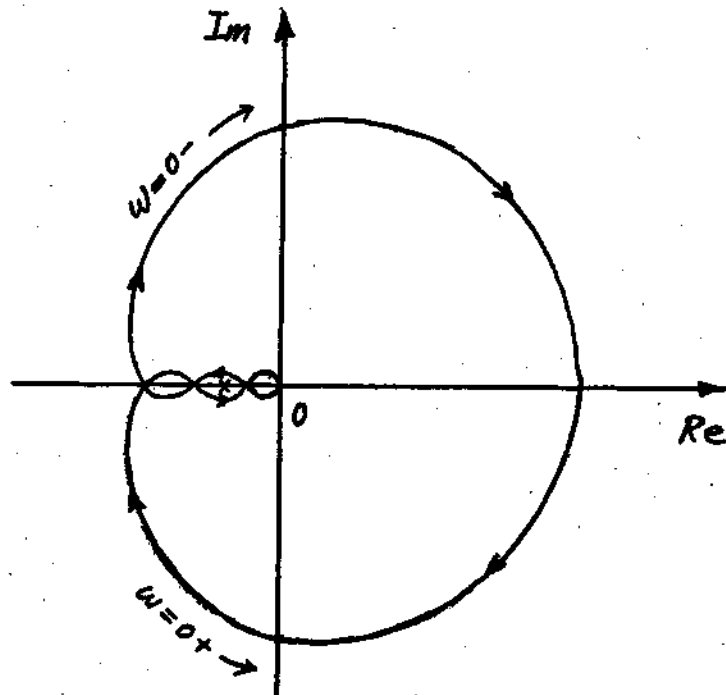

**B-8-20.**

$$G(s) = \frac{K(s+2)}{s(s+1)(s+10)}$$

A MATLAB program to plot Nyquist diagrams of  $G(s)$  for  $K = 1$ ,  $K = 10$ , and  $K = 100$  is shown below. The resulting Nyquist diagrams are shown on the next page.

```
%*****Nyquist Diagrams*****
num = [1 2];
den = [1 11 10 0];
w = 0.1:0.1:100;
[re1,im1,w] = nyquist(num,den,w);
[re2,im2,w] = nyquist(10*num,den,w);
[re3,im3,w] = nyquist(100*num,den,w);
plot(re1,im1,re2,im2,re3,im3)
v = [-2 2 -2 2]; axis(v)
grid
title('Nyquist Diagrams')
xlabel('Real Axis')
ylabel('Imag Axis')
text(0.1,-0.75,'K = 1')
text(0.1,-1.25,'K = 10')
text(-1.6,-1.25,'K = 100')
```

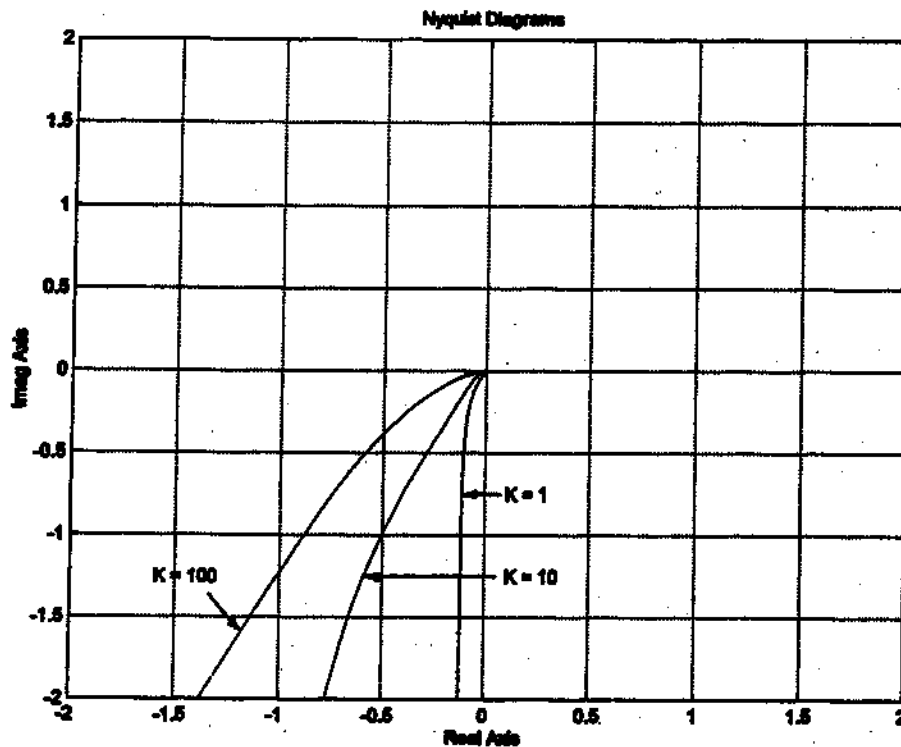

B-8-21.

$$G(s) = \frac{2}{s(s+1)(s+2)}$$

The Nyquist diagrams for  $G(s)$  and  $-G(s)$  are symmetric about the imaginary axis. A MATLAB program for plotting the Nyquist diagrams for the two cases is shown below. The resulting Nyquist diagrams are shown on the next page.

```

% ***** Nyquist Diagrams of G(s) and -G(s) *****
num1 = [0 0 0 2];
den1 = [1 3 2 0];
num2 = [0 0 0 -2];
den2 = [1 3 2 0];
nyquist(num1,den1)
hold
Current plot hold
nyquist(num2,den2)
v = [-4 4 -4 4]; axis(v)
grid
text(-2.6,-1.5,'G(s)')
text(2.2,-1.5,'-G(s)')

```

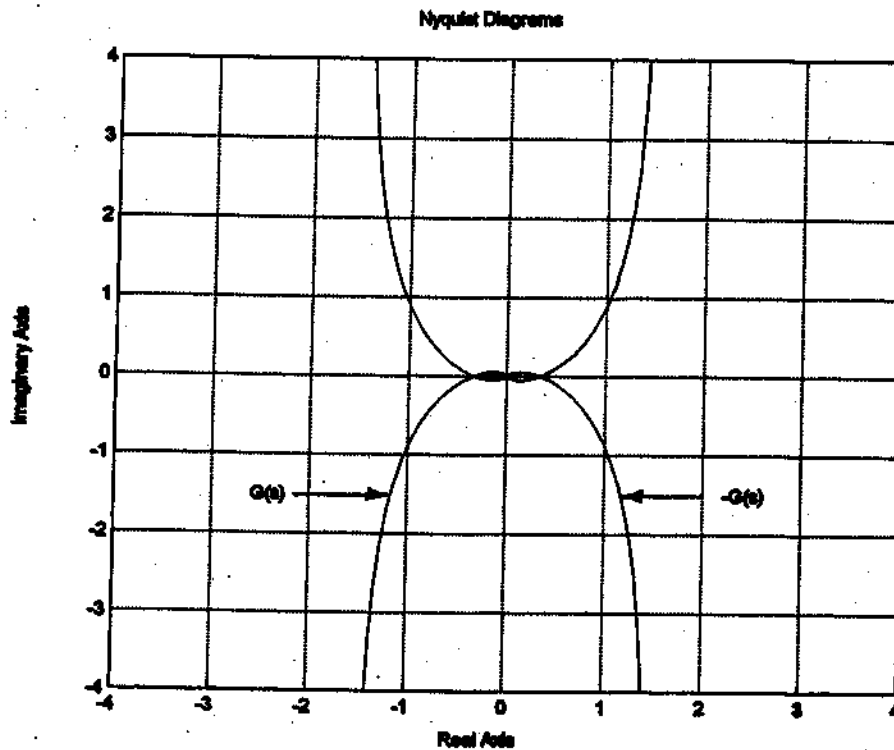

B-8-22.

$$G(s) = \frac{10}{s^3 + 6s^2 + (5 + 10k)s}$$

A MATLAB program for plotting Nyquist diagrams of  $G(s)$  for  $k = 0.3$ ,  $k = 0.5$ , and  $k = 0.7$  is shown below. The resulting Nyquist diagrams are shown on the next page.

```

%*****Nyquist Diagrams*****

num = [0 0 0 10];
den1 = [1 6 8 0]; % k=0.3
den2 = [1 6 10 0]; % k=0.5
den3 = [1 6 12 0]; % k=0.7
w = 0.1:0.1:100;
[re1,im1,w] = nyquist(num,den1,w);
[re2,im2,w] = nyquist(num,den2,w);
[re3,im3,w] = nyquist(num,den3,w);
plot(re1,im1,re2,im2,re3,im3)
v = [-1.5 0.5 -4 4]; axis(v)
grid
title('Nyquist Diagrams')
xlabel('Real Axis')
ylabel('Imag Axis')
text(-0.25,-1.5,'k = 0.3')
text(-0.25,-2.5,'k = 0.5')
text(-1.25,-1.5,'k = 0.7')

```

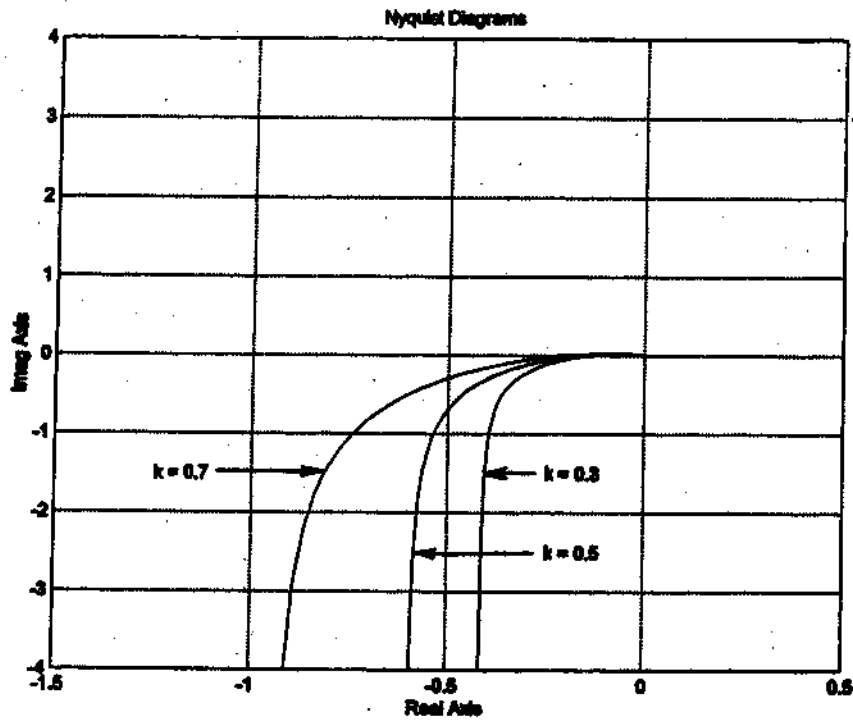

B-8-23.

$$G(s) = \frac{K(s+1)}{s^2 - 0.25}$$

A MATLAB program to plot Bode diagrams of  $G(s)$  for  $K = 0.2, 0.5,$  and  $2$  is shown below. The resulting Bode diagrams are shown on the next page.

```

% **** Bode Diagrams ****
num = [0 1 1];
den = [1 0 -0.25];
w = logspace(-1,2,100);
bode(0.2*num,den,w)
hold
Current plot held
bode(0.5*num,den,w)
bode(2*num,den,w)
gtext('K = 0.2')
gtext('K = 0.5')
gtext('K = 2')
gtext('Phase curve is the same for all K values.')

```

### Bode Diagrams

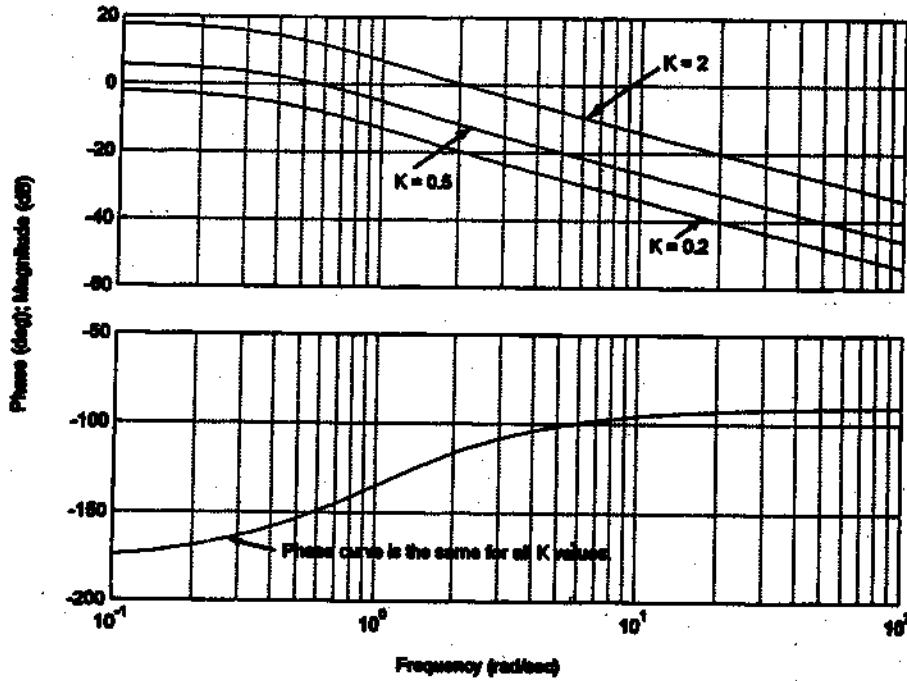

A MATLAB program to plot Nyquist diagrams of  $G(s)$  for  $K = 0.2, 0.5,$  and  $2$  is shown below. The resulting Nyquist diagrams are shown on the next page.

```

% ***** Nyquist Diagrams *****
num = [0 1 1];
den = [1 0 -0.25];
w = 0.01:0.01:20;
[re1,im1,w] = nyquist(0.2*num,den,w);
[re2,im2,w] = nyquist(0.5*num,den,w);
[re3,im3,w] = nyquist(2*num,den,w);
plot(re1,im1,re2,im2,re3,im3)
v = [-9 1 -3 3]; axis(v)
grid
gtext('K = 0.2')
gtext('K = 0.5')
gtext('K = 2')
title('Nyquist Diagrams')
xlabel('Real Axis')
ylabel('Imag Axis')

```

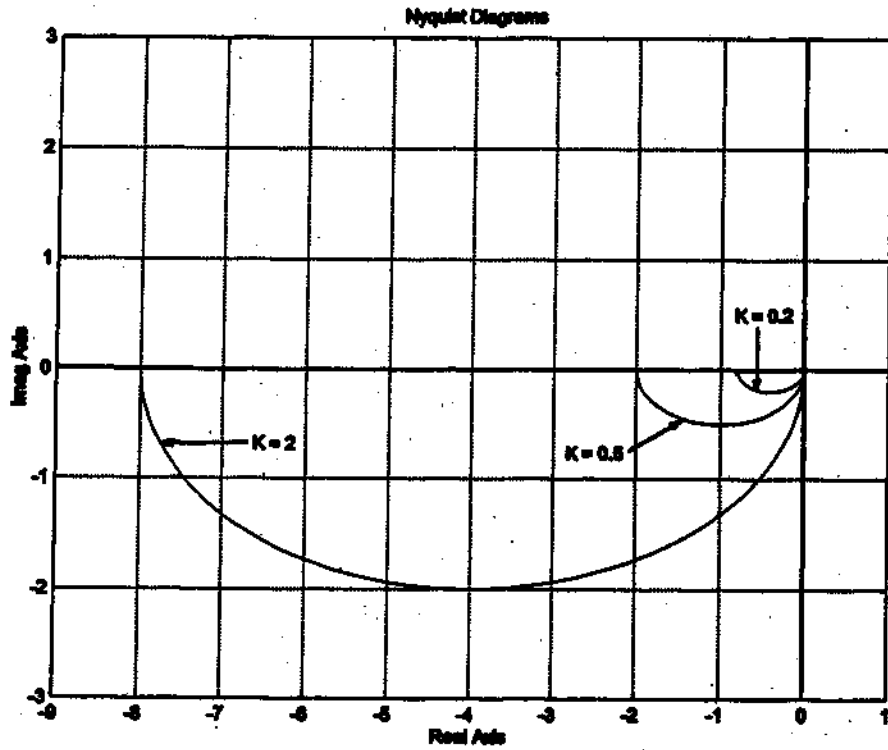

A root-locus diagram for the given  $G(s)$  is shown below. The MATLAB program that produced this root-locus diagram is shown on the next page.

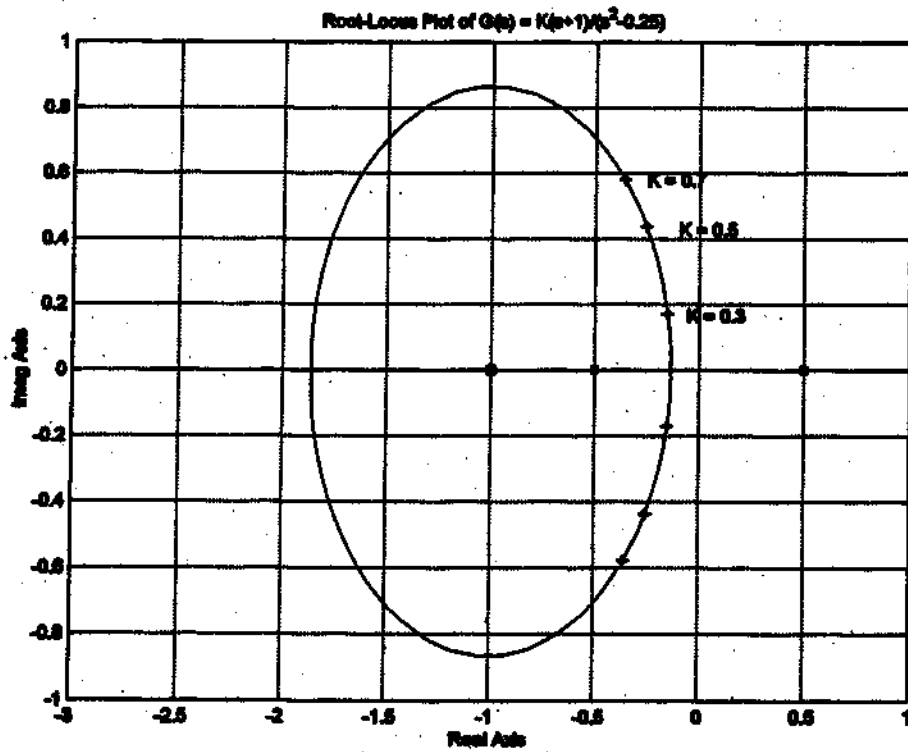

```

% ***** Root-Locus Plot *****

num = [0 1 1];
den = [1 0.0000001 -0.25];
rlocus(num,den)
grid
title('Root-Locus Plot of G(s) = K(s+1)/(s^2-0.25)')
text(-0.06,0.166,'K = 0.3')
text(-0.1,0.43,'K = 0.5')
text(-0.25,0.58,'K = 0.7')

% To locate a point where K assumes a given value, we may use the
% rlocfind command. For example, to locate a point where K = 0.3,
% enter the command [K,r] = rlocfind(num,den) and select a probable
% point on a root locus.

[K,r] = rlocfind(num,den)
Select a point in the graphics window

selected_point =

-0.1594+ 0.1642i

K =

0.3000

r =

-0.1500+ 0.1658i
-0.1500- 0.1658i

% At point -0.1500 + j0.1658, the K value is 0.30000.

```

**B-8-24.** The following MATLAB program produces two Nyquist plots for the input  $u_1$  in one diagram and two Nyquist plots for the input  $u_2$  in another diagram.

```

% ***** Nyquist plots *****

% ***** We shall first obtain Nyquist plots when the input is
% u1. Then we shall obtain Nyquist plots when the input is
% u2 *****

% ***** Enter matrices A, B, C, and D *****

A = [-1 -1;6.5 0];
B = [1 1;1 0];
C = [1 0;0 1];
D = [0 0;0 0];

```

```
% ***** To obtain Nyquist plots when the input is u1, enter  
% the command 'nyquist(A,B,C,D,1)' *****
```

```
nyquist(A,B,C,D,1)  
grid  
title('Nyquist Plots : Input = u1 (u2 = 0)')  
text(0.1,0.7,'Y1')  
text(0.1,2.5,'Y2')
```

```
% ***** Next, we shall obtain Nyquist plots when the input is  
% u2. Enter the command 'nyquist(A,B,C,D,2)' *****
```

```
nyquist(A,B,C,D,2)  
grid  
title('Nyquist Plots : Input = u2 (u1 = 0)')  
text(0.1,0.5,'Y1')  
text(0.1,2.2,'Y2')
```

The Nyquist plots obtained by this MATLAB program are shown below.

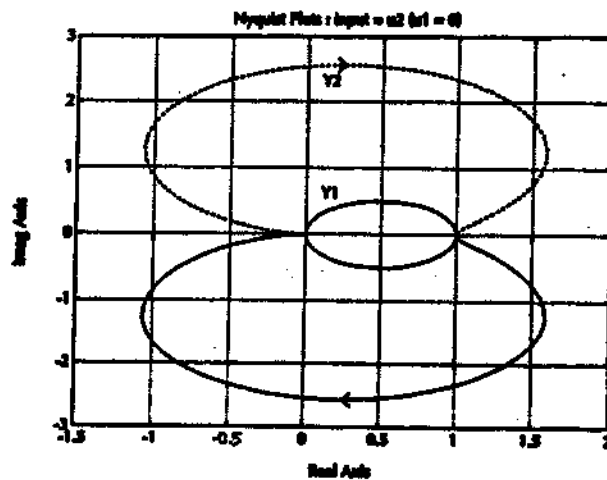
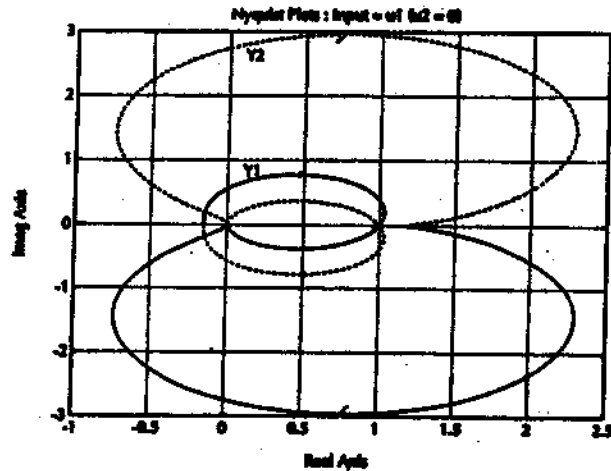

B-8-25. The following MATLAB program produces the Nyquist plot for  $Y_1(j\omega)/U_1(j\omega)$  for  $\omega > 0$ . The plot obtained is shown below.

```

% ***** Nyquist plot *****
A = [-1 -1;6.5 0];
B = [1 1;1 0];
C = [1 0;0 1];
D = [0 0;0 0];
[re,im,w] = nyquist(A,B,C,D,1);
re1 = re*[1;0];
im1 = im*[1;0];
plot(re1,im1)
grid
title('Nyquist Plot for Y1(jw)/U1(jw)')
xlabel('Real Axis')
ylabel('Imag Axis')

```

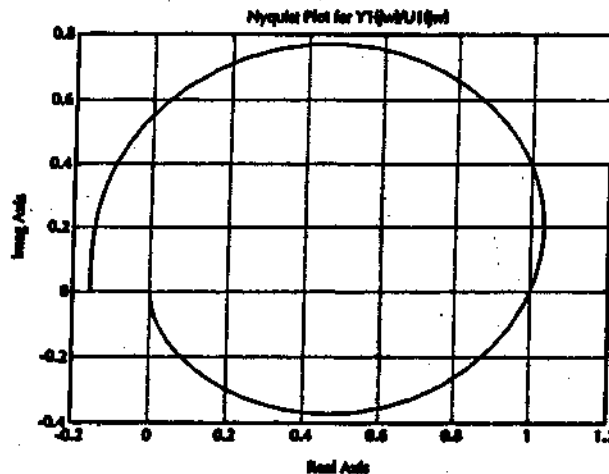

To plot the Nyquist locus for  $-\infty < \omega < \infty$ , replace the plot command `plot(re1,im1)` in the above MATLAB program by `plot(re1,im1,rel,-im1)`.

B-8-26.

$$|G(j\omega)| = \frac{\sqrt{a^2\omega^2 + 1}}{\omega^2}, \quad \angle G(j\omega) = \tan^{-1} a\omega - 180^\circ$$

The phase margin of  $45^\circ$  at  $\omega = \omega_1$  requires that

$$\frac{\sqrt{a^2\omega_1^2 + 1}}{\omega_1^2} = 1$$

$$\tan^{-1} a\omega_1 - 180^\circ = 45^\circ - 180^\circ$$

Thus, we have

$$a^2 \omega_1^2 + 1 = \omega_1^2, \quad a \omega_1 = 1$$

Solving for a, we obtain

$$a = \left( \frac{1}{\sqrt{2}} \right)^{\frac{1}{2}} = 0.841$$

**B-8-27.** A Bode diagram of the system is shown below.

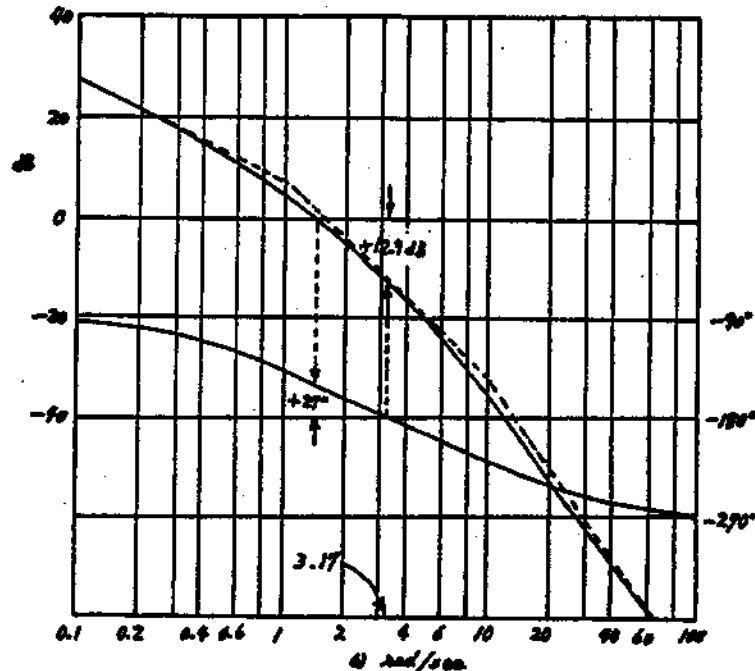

From this Bode diagram, we find the phase margin and gain margin to be 27° and 13 dB, respectively.

The phase margin, gain margin, phase crossover frequency, and gain crossover frequency can be obtained easily with MATLAB. Use the command

$$[Gm, pm, wcp, wcg] = \text{margin}(\text{sys})$$

See Problem B-8-28.

**B-8-28.**

$$G(s) = \frac{20(s+1)}{s(s^2+2s+10)(s+5)}$$

The phase margin, gain margin, phase crossover frequency, and gain crossover frequency are obtained by use of the command

$$[Gm, pm, wcp, wcg] = \text{margin}(\text{sys})$$

A MATLAB program to solve this problem is given below. The Bode diagram shown below verifies the phase margin, gain margin, phase crossover frequency, and gain crossover frequency obtained with MATLAB.

```

% ***** Bode Diagram *****

num = [0 0 0 20 20];
den = conv([1 2 10 0],[1 5]);
sys = tf(num,den);
w = logspace(-1,2,100);
bode(sys,w)
title('Bode Diagram of G(s) = 20(s+1)/(s^2+2s+10)(s+5)')
[Gm,pm,wcp,wcg] = margin(sys);
Gm dB = 20*log10(Gm);
[Gm dB pm wcp wcg]

ans =

9.9293 103.6573 4.0131 0.4426
    
```

Bode Diagram of  $G(s) = 20(s+1)/(s^2+2s+10)(s+5)$

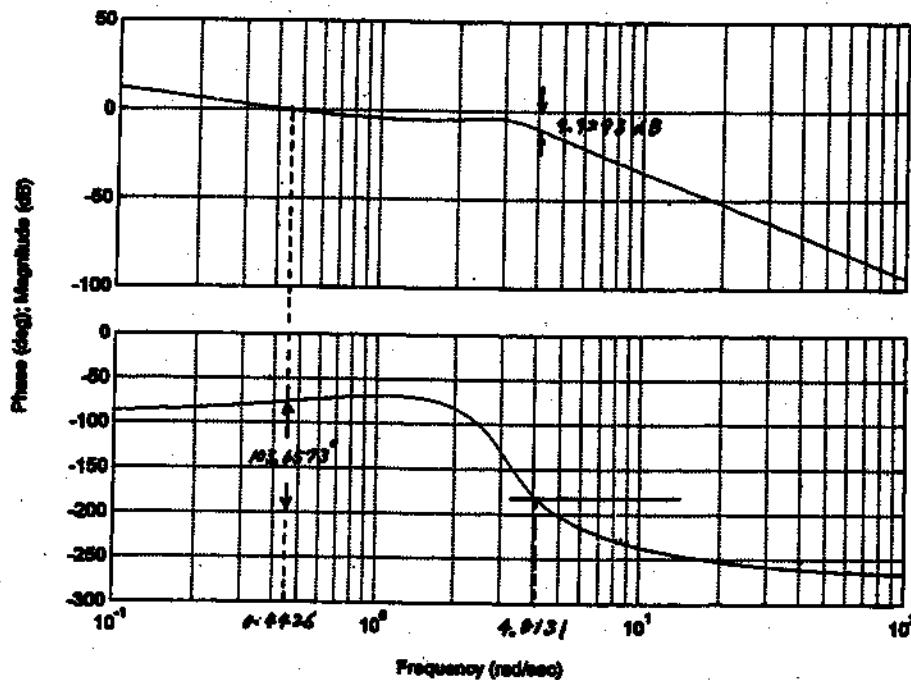

B-8-29.

$$G(s) = \frac{K}{s(s^2 + s + 4)} = \frac{0.25K}{s(0.25s^2 + 0.25s + 1)}$$

The quadratic term in the denominator has the undamped natural frequency of 2 rad/sec and the damping ratio of 0.25. Define the frequency corresponding to the angle of  $-130^\circ$  to be  $\omega_1$ .

$$\begin{aligned} |G(j\omega_1)| &= -\angle j\omega_1 - \angle \frac{1 - 0.25\omega_1^2 + j0.25\omega_1}{1 - 0.25\omega_1^2} \\ &= -90^\circ - \tan^{-1} \frac{0.25\omega_1}{1 - 0.25\omega_1^2} = -130^\circ \end{aligned}$$

Solving this last equation for  $\omega_1$ , we find  $\omega_1 = 1.491$ . Thus, the phase angle becomes equal to  $-130^\circ$  at  $\omega = 1.491$  rad/sec. At this frequency, the magnitude must be unity, or  $|G(j\omega_1)| = 1$ . The required gain  $K$  can be determined from

$$|G(j1.491)| = \left| \frac{0.25K}{(j1.491)(-0.555 + j0.3725 + 1)} \right| = 0.2890K$$

Setting  $|G(j1.491)| = 0.2890K = 1$ , we find

$$K = 3.46$$

Note that the phase crossover frequency is at  $\omega = 2$  rad/sec, since

$$\angle G(j2) = -\angle j2 - \angle \frac{-0.25 \times 2^2 + 0.25 \times j2 + 1}{-0.25 \times 2^2 + 0.25 \times j2 + 1} = -90^\circ - 90^\circ = -180^\circ$$

The magnitude  $|G(j2)|$  with  $K = 3.46$  becomes

$$|G(j2)| = \left| \frac{0.865}{(j2)(-1 + 0.5j + 1)} \right| = 0.865 = -1.26 \text{ dB}$$

Thus, the gain margin is 1.26 dB. The Bode diagram of  $G(j\omega)$  with  $K = 3.46$  is shown below.

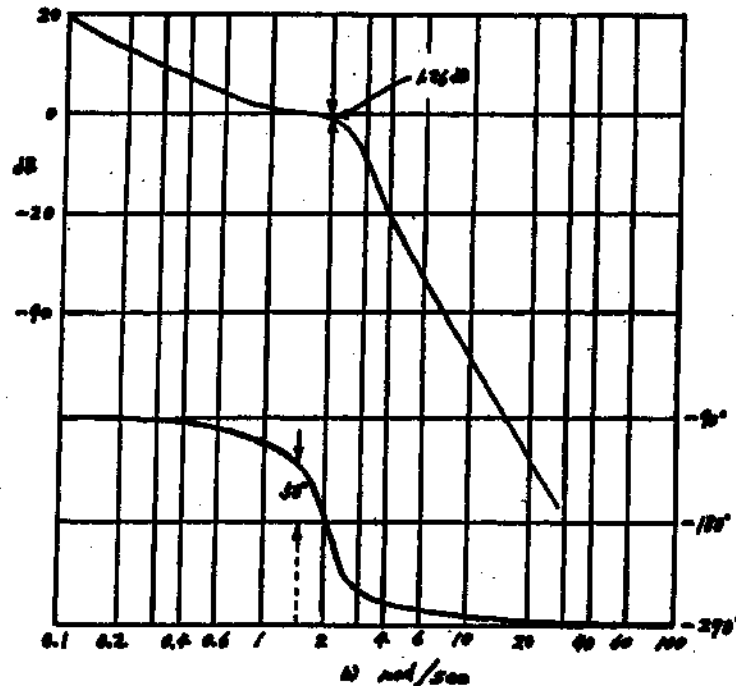

B-8-30. Note that

$$K \frac{j\omega + 0.1}{j\omega + 0.5} \frac{10}{j\omega(j\omega + 1)} = \frac{2K(10j\omega + 1)}{j\omega(2j\omega + 1)(j\omega + 1)}$$

We shall plot the Bode diagram when  $2K = 1$ . That is, we plot the Bode diagram of

$$G(j\omega) = \frac{10j\omega + 1}{j\omega(2j\omega + 1)(j\omega + 1)}$$

The diagram is shown below. The phase curve shows that the phase angle is  $-130^\circ$  at  $\omega = 1.438$  rad/sec. Since we require the phase margin to be  $50^\circ$ , the magnitude of  $G(1.438)$  must be equal to 1 or 0 dB. Since the Bode diagram indicates that  $G(1.438)$  is 5.48 dB, we need to choose  $2K = -5.48$  dB, or

$$K = 0.266$$

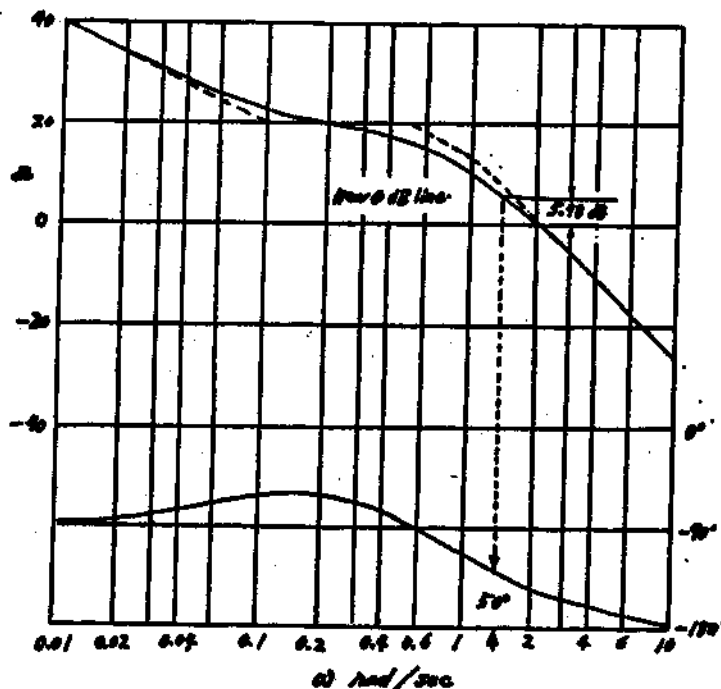

Since the phase curve lies above the  $-180^\circ$  line for all  $\omega$ , the gain margin is  $+\infty$  dB.

B-8-31. Note that

$$G(s) = \frac{K}{s(s^2 + s + 0.5)} = \frac{2K}{s(2s^2 + 2s + 1)}$$

We shall first plot a Bode diagram of  $G(j\omega)$  when  $K = 0.5$ . That is, we plot a Bode diagram for

$$G(j\omega) = \frac{1}{j\omega[2(j\omega)^2 + 2j\omega + 1]}$$

It is shown below. By reading the magnitude and phase angle values at each frequency point considered, the log-magnitude versus phase curve can be plotted as shown below the Bode diagram. By moving the curve vertically, we can shift the curve to be tangent to the  $M = 2$  dB locus. The vertical shift needed is 9.3 dB. That is, if we lower the curve by 9.3 dB, then it is tangent to the  $M = 2$  dB locus. Therefore, we set

$$2K = -9.3 \text{ dB}$$

Solving this equation for  $K$  determines the desired value of  $K$  as

$$K = 0.1714$$

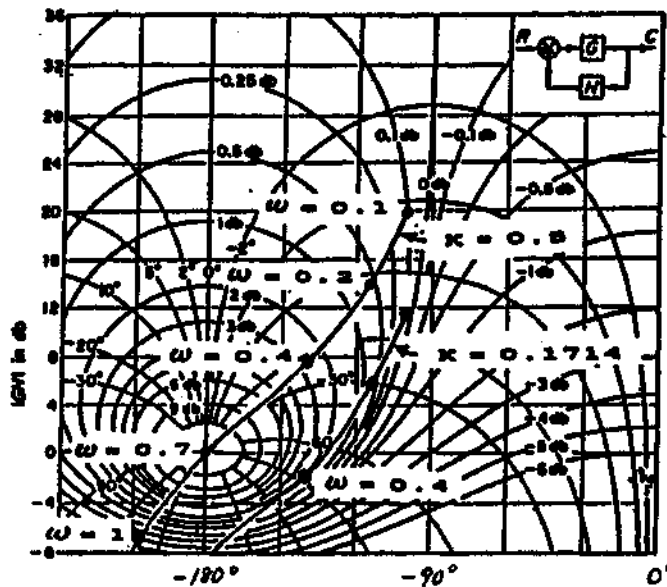
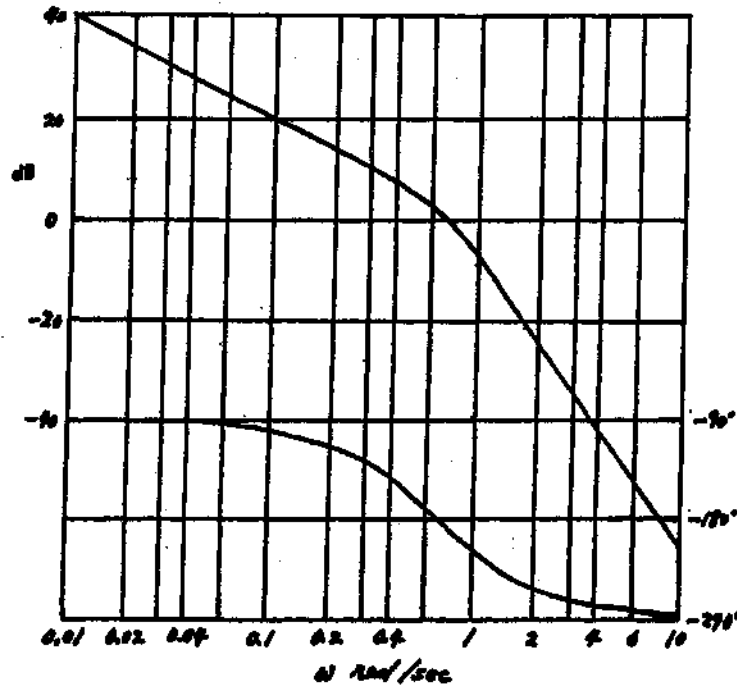

B-8-32. For this system

$$G(j\omega) = K \frac{e^{-j\omega}}{j\omega + 1}$$

By setting  $K = 1$ , we draw a Nyquist diagram as shown below, Note that

$$\angle e^{-j\omega} = -\omega \text{ (rad)} = -57.3^\circ \omega$$

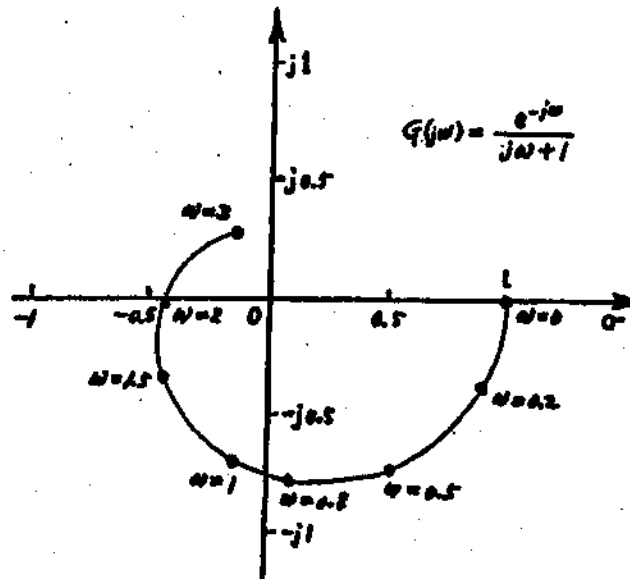

The Nyquist locus crosses the negative real axis at  $\sigma = -0.442$ . Hence, for stability, we require

$$\frac{1}{0.442} > K > 0$$

or

$$2.262 > K > 0$$

The same result can also be obtained analytically. Since

$$\begin{aligned} G(j\omega) &= \frac{K e^{-j\omega}}{j\omega + 1} = \frac{K (\cos \omega - j \sin \omega)(1 - j\omega)}{(1 + j\omega)(1 - j\omega)} \\ &= \frac{K}{1 + \omega^2} \left[ (\cos \omega - \omega \sin \omega) + j (\sin \omega + \omega \cos \omega) \right] \end{aligned}$$

by setting the imaginary part of  $G(j\omega)$  equal to zero, we obtain

$$\sin \omega + \omega \cos \omega = 0$$

or

$$\omega = -\tan \omega$$

Solving this equation for the smallest positive value of  $\omega$ , we obtain

$$\omega = 2.029$$

Substituting  $\omega = 2.029$  into  $G(j\omega)$  yields

$$\begin{aligned} G(j2.029) &= \frac{K}{1+2.029^2} (\cos 2.029 - 2.029 \times \sin 2.029) \\ &= -0.4421 K \end{aligned}$$

The critical value of  $K$  for stability can be obtained by letting  $G(j2.029) = -1$ , or

$$0.4421 K = 1$$

Thus, the range of gain  $K$  for stability is

$$2.262 > K > 0$$

B-8-33. The magnitude of  $G(j\omega)H(j\omega)$  is

$$|G(j\omega)H(j\omega)| = \frac{K}{\omega\sqrt{\omega^2+1}}$$

The phase angle of  $G(j\omega)H(j\omega)$  is

$$\angle G(j\omega)H(j\omega) = -T\omega - 90^\circ - \tan^{-1}\omega$$

The maximum value of  $K$  for stability can be determined from the following two equations:

$$\frac{K}{\omega\sqrt{\omega^2+1}} = 1, \quad -T\omega - 90^\circ - \tan^{-1}\omega = -180^\circ$$

By eliminating  $\omega$  from these two equations, we can obtain the maximum value of  $K$  for stability as a function of dead time  $T$ . A graphical solution is given in the figure shown below.

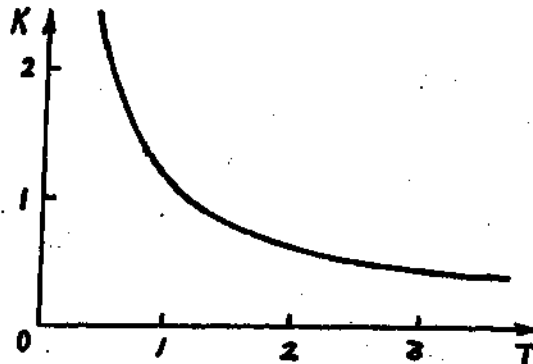

**B-8-34.** Polar plots of  $G(j\omega)$  and  $e^{-jT\omega}$  are shown on next page. From the plots, we see that  $G(j\omega)$  gives a good approximation to the transport lag  $e^{-jT\omega}$  for the frequency range  $0 < \omega T < 2\sqrt{3}$ .

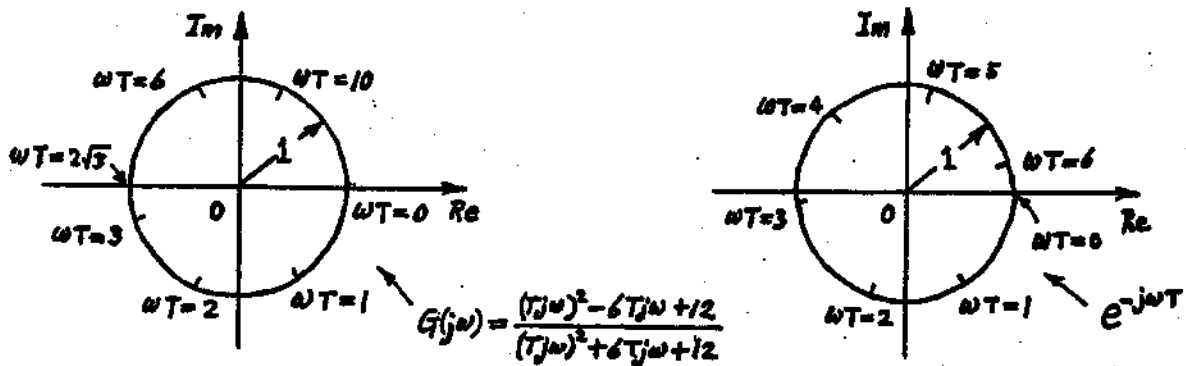

**B-8-35.**

$$G(s) = \frac{10}{s(0.175s + 1)}$$

**B-8-36.** From the magnitude curve the transfer function for  $G(j\omega)$  may be approximated by

$$\hat{G}(s) = \frac{1}{0.459s + 1}$$

The phase curve of  $\hat{G}(j\omega)$  differs from the given phase curve. Therefore, we expect the presence of the transport lag and/or minimum-phase transfer function of the form

$$e^{-Ls}, \quad \frac{1-Ts}{1+Ts}, \quad \frac{1+Ts}{1-Ts}$$

Hence, we may assume  $G(j\omega)$  to be

$$G(j\omega) = \frac{1}{0.459j\omega + 1} e^{-Lj\omega} \left( \frac{1-T_1j\omega}{1+T_1j\omega} \right) \left( \frac{1+T_2j\omega}{1-T_2j\omega} \right)$$

By use of a curve fitting process, we find

$$G(j\omega) = \frac{1}{0.459j\omega + 1} e^{-j\frac{\omega}{6.75}} \left( \frac{1-0.95j\omega}{1+0.45j\omega} \right) \left( \frac{1+0.14j\omega}{1-0.14j\omega} \right)$$

Thus, the transfer function  $G(s)$  is

$$G(s) = \frac{1}{0.459s + 1} e^{-\frac{s}{6.75}} \left( \frac{1-0.45s}{1+0.45s} \right) \left( \frac{1+0.14s}{1-0.14s} \right)$$

# CHAPTER 9

B-9-1.

(a)

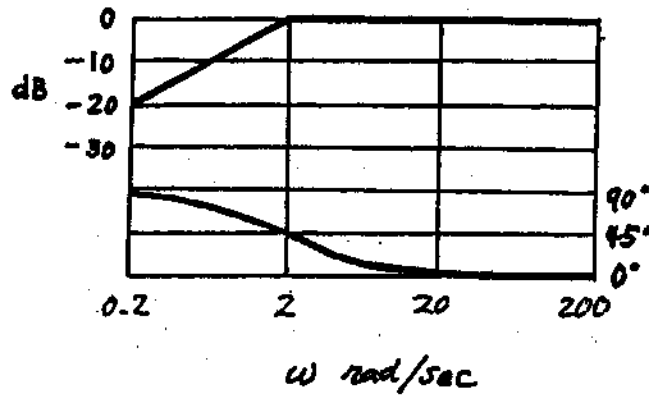

(b)

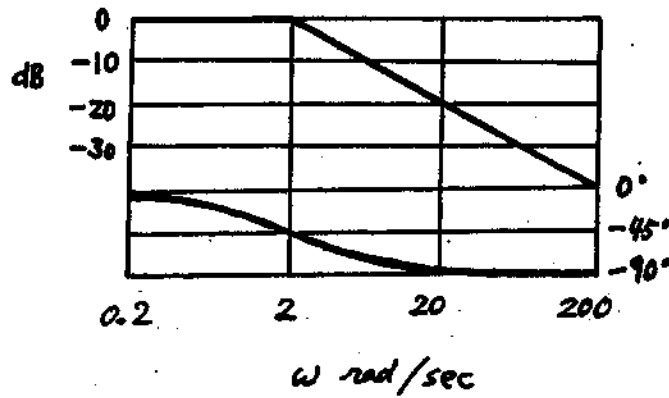

B-9-2.

$$G_C(s) = 5 \left( 1 + \frac{1}{2s} \right)$$

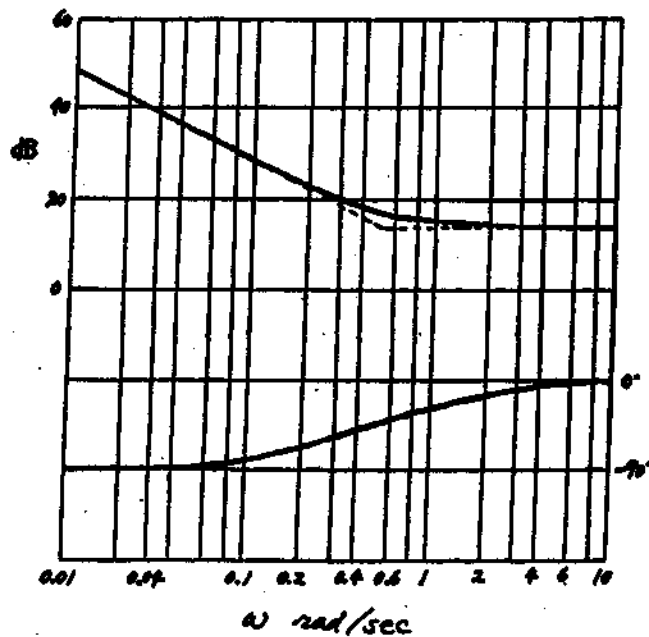

$$G_C(s) = 5(1 + 0.5s)$$

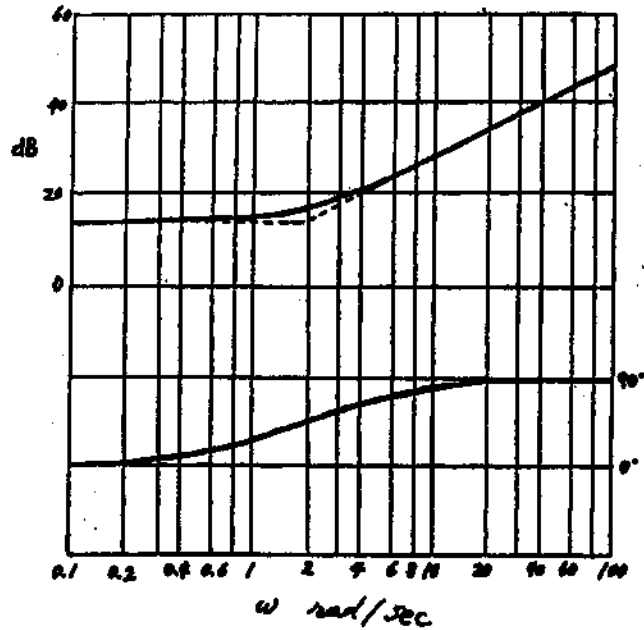

**B-9-3.** The following MATLAB program produces the Bode diagram of the given  $G_C(s)$ .

```

% ***** Bode diagram *****

num = [30.3215 39.41795 12.810834];
den = [0 1 0];
bode(num,den)
title('Bode Diagram of G(s) = 30.3215(s+0.65)^2/s')

```

Bode Diagram of  $G(s) = 30.3215(s+0.65)^2/s$

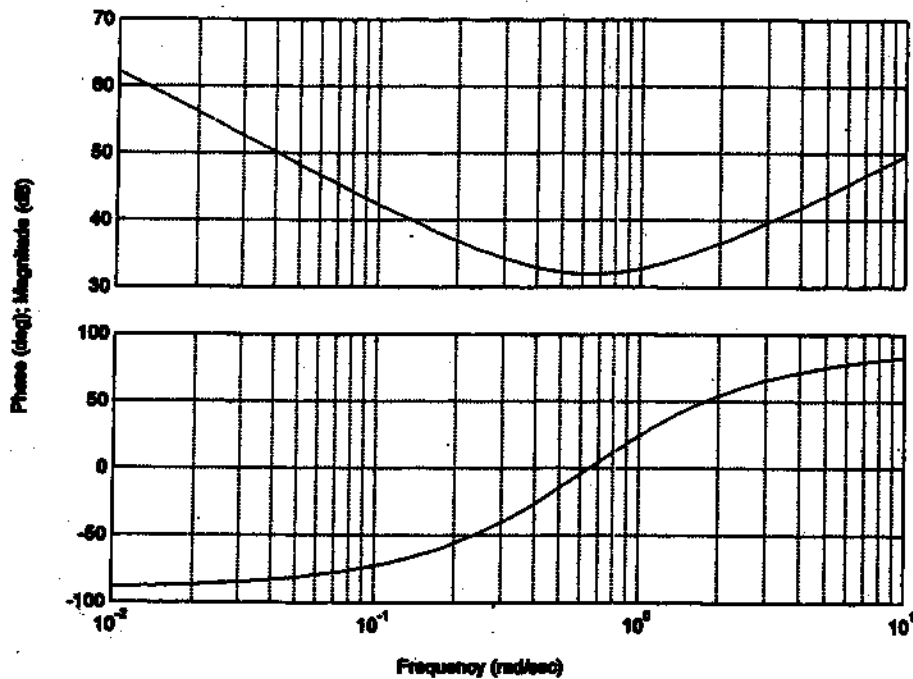

**B-9-4.** Choose the gain crossover frequency to be approximately 0.4 rad/sec and the phase margin to be approximately 60°. Draw the high frequency asymptote having the slope of -20 dB/dec to cross the 0 dB line at about  $\omega = 0.35$  rad/sec. Choose the corner frequency to be 0.25 rad/sec. Then the low-frequency asymptote can be drawn on Bode diagram. See the Bode diagram shown below.

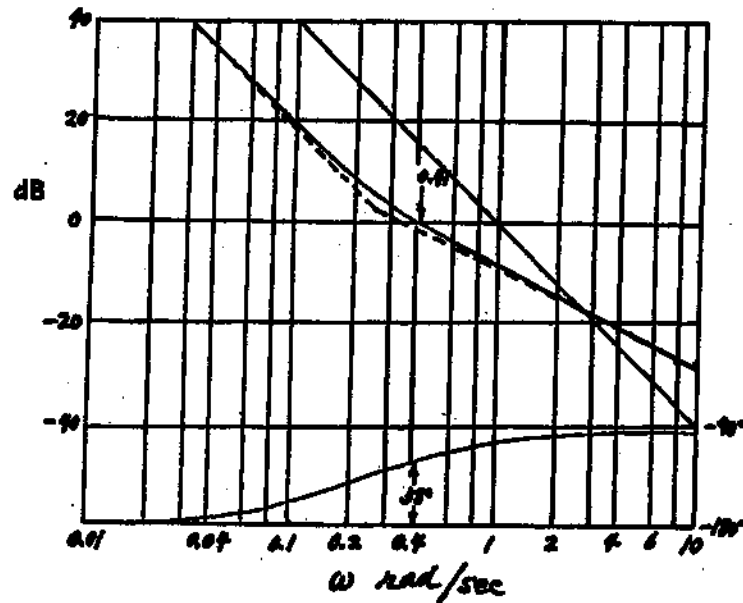

The actual magnitude curve crosses the 0 dB line at about  $\omega = 0.41$  rad/sec and the phase margin is approximately 58°.

Since we have chosen the corner frequency to be 0.25 rad/sec, we get

$$T_d = 4$$

From the Bode diagram,  $K_d$  must be chosen to be -21.4 dB, or

$$K_d = -21.4 \text{ dB} = 0.0851$$

Thus

$$K_d(1 + T_d s) = 0.0851(1 + 4s)$$

Then, the open-loop transfer function becomes

$$G(s) = \frac{0.0851(1 + 4s)}{s^2}$$

The closed-loop transfer function is

$$\frac{C(s)}{R(s)} = \frac{0.0851(1 + 4s)}{s^2 + 0.0851(1 + 4s)} = \frac{4s + 1}{11.751s^2 + 4s + 1}$$

A Bode diagram of

$$\frac{C(j\omega)}{R(j\omega)} = \frac{4j\omega + 1}{11.751(j\omega)^2 + 4j\omega + 1}$$

is shown on the next page. From this diagram we see that the bandwidth is approximately 0.5 rad/sec.

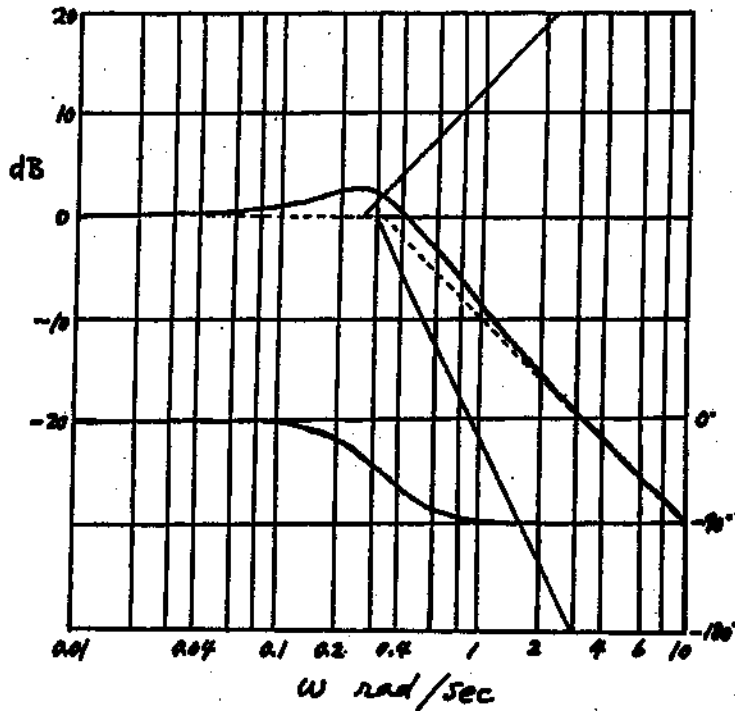

**B-9-5.** Let us use the following lead compensator:

$$G_c(s) = K_c \alpha \frac{Ts+1}{\alpha Ts+1} = K_c \frac{s + \frac{1}{T}}{s + \frac{1}{\alpha T}}$$

Since  $K_v$  is specified as  $4.0 \text{ sec}^{-1}$ , we have

$$K_v = \lim_{s \rightarrow 0} s K_c \alpha \frac{Ts+1}{\alpha Ts+1} \frac{K}{s(\alpha s+1)(s+1)} = K_c \alpha K = 4$$

Let us set  $K = 1$  and define  $K_c \alpha = \hat{K}$ . Then

$$\hat{K} = 4$$

Next, plot a Bode diagram of

$$\frac{4}{s(0.1s+1)(s+1)} = \frac{4}{0.1s^3 + 1.1s^2 + s}$$

The following MATLAB program produces the Bode diagram shown on the next page.

```
% ***** Bode diagram *****
num = [0 0 0 4];
den = [0.1 1.1 1 0];
bode(num,den)
title('Bode Diagram of G(s) = 4/[s(0.1s+1)(s+1)]')
```

Bode Diagram of  $G(s) = 4/[s(0.1s+1)(s+1)]$

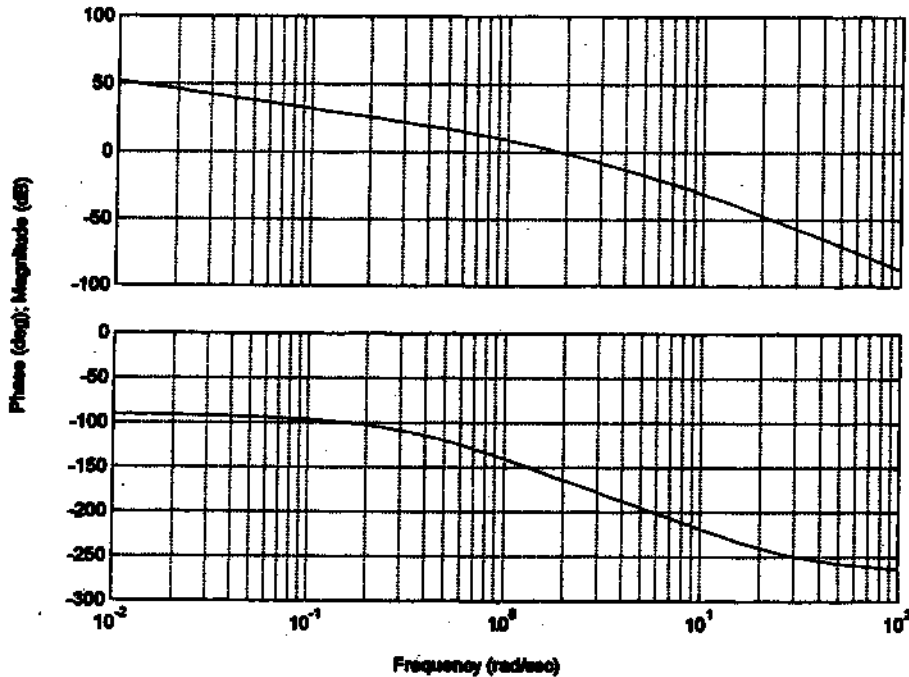

From this plot, the phase and gain margins are  $17^\circ$  and 8.7 dB, respectively.

Since the specifications call for a phase margin of  $45^\circ$ , let us choose

$$\phi_m = 45^\circ - 17^\circ + 12^\circ = 40^\circ$$

(This means that  $12^\circ$  has been added to compensate for the shift in the gain crossover frequency.) The maximum phase lead is  $40^\circ$ . Since

$$\sin \phi_m = \frac{1-\alpha}{1+\alpha} \quad (\phi_m = 40^\circ)$$

$\alpha$  is determined as 0.2174. Let us choose, instead of 0.2174,  $\alpha$  to be 0.21, or

$$\alpha = 0.21$$

Next step is to determine the corner frequencies  $\omega = 1/T$  and  $\omega = 1/(\alpha T)$  of the lead compensator. Note that the maximum phase-lead angle  $\phi_m$  occurs at the geometric mean of the two corner frequencies, or  $\omega = 1/(\sqrt{\alpha} T)$ . The amount of the modification in the magnitude curve at  $\omega = 1/(\sqrt{\alpha} T)$  due to the inclusion of the term  $(Ts + 1)/(\alpha Ts + 1)$  is

$$\left| \frac{1+j\omega T}{1+j\omega\alpha T} \right|_{\omega = \frac{1}{\sqrt{\alpha} T}} = \frac{1}{\sqrt{\alpha}}$$

Note that

$$\frac{1}{\sqrt{\alpha}} = \frac{1}{\sqrt{0.21}} = 2.1822 = 6.7778 \text{ dB}$$

We need to find the frequency point where, when the lead compensator is added, the total magnitude becomes 0 dB. The magnitude  $G(j\omega)$  is -6.7778 dB corres-

ponds to  $\omega = 2.81$  rad/sec. We select this frequency to be the new gain cross-over frequency  $\omega_c$ . Then we obtain

$$\frac{1}{T} = \sqrt{\alpha} \omega_c = \sqrt{0.21} \times 2.81 = 1.2877$$

$$\frac{1}{\alpha T} = \frac{\omega_c}{\sqrt{\alpha}} = \frac{2.81}{\sqrt{0.21}} = 6.1319$$

Hence

$$G_c(s) = K_c \frac{s + 1.2877}{s + 6.1319}$$

and

$$K_c = \frac{\hat{K}}{\alpha} = \frac{4}{0.21}$$

Thus

$$G_d(s) = \frac{4}{0.21} \frac{s + 1.2877}{s + 6.1319} = 4 \frac{0.7766s + 1}{0.16308s + 1}$$

The open-loop transfer function becomes as

$$\begin{aligned} G_c(s) G(s) &= 4 \frac{0.7766s + 1}{0.16308s + 1} \frac{1}{s(0.1s + 1)(s + 1)} \\ &= \frac{3.1064s + 4}{0.01631s^4 + 0.2794s^3 + 1.2631s^2 + 4.1064s + 4} \end{aligned}$$

The closed-loop transfer function is

$$\frac{C(s)}{R(s)} = \frac{3.1064s + 4}{0.01631s^4 + 0.2794s^3 + 1.2631s^2 + 4.1064s + 4}$$

The following MATLAB program produces the unit-step response curve as shown on the next page.

```

% ***** Unit-step response *****

numc = [0 0 0 3.1064 4];
denc = [0.01631 0.2794 1.2631 4.1064 4];
step(numc,denc)
grid
title('Unit-Step Response of Compensated System (Problem B-9-5)')
```

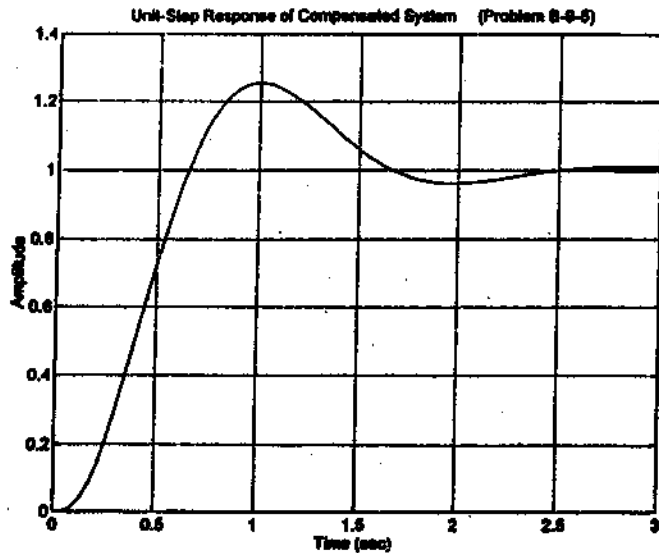

Similarly, the following MATLAB program produces the unit-ramp response curve as shown below.

```

% ***** Unit-ramp response *****
numc = [0 0 0 0 3.1064 4];
denc = [0.01631 0.2794 1.2631 4.1064 4 0];
t = 0:0.01:5;
c = step(numc,denc,t);
plot(t,c,t)
grid
title('Unit-Ramp Response of Compensated System (Problem B-9-5)')
xlabel('t Sec')
ylabel('Unit-Ramp Input and System Output')

```

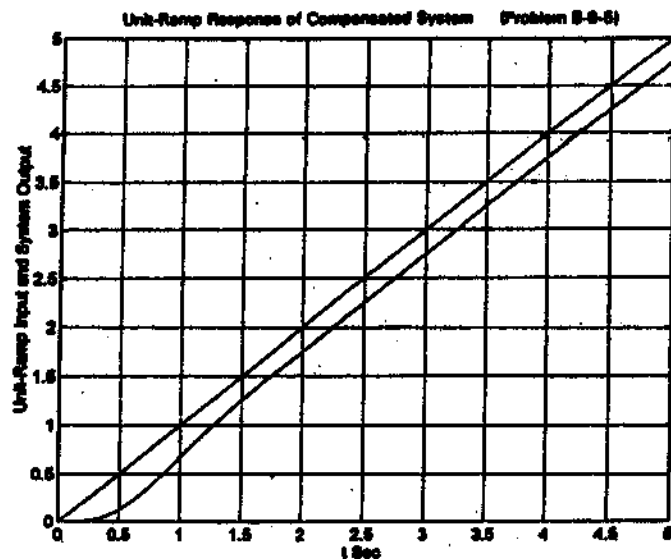

**B-9-6.** To satisfy the requirements, try a lead compensator  $G_c(s)$  of the form

$$G_c(s) = K_c \alpha \frac{Ts+1}{\alpha Ts+1} = K_c \frac{s + \frac{1}{T}}{s + \frac{1}{\alpha T}}$$

Define

$$G_1(s) = K G(s) = \frac{K}{s(s+1)}$$

where  $K = K_c \alpha$ . Since the static velocity error constant  $K_v$  is given as  $50 \text{ sec}^{-1}$ , we have

$$K_v = \lim_{s \rightarrow 0} s G_c(s) G(s) = \lim_{s \rightarrow 0} s \frac{Ts+1}{\alpha Ts+1} \frac{K}{s(s+1)} = K = 50$$

We shall now plot a Bode diagram of

$$G_1(s) = \frac{50}{s(s+1)}$$

The following MATLAB program produces the Bode diagram shown below.

```

% ***** Bode diagram *****
num = [0 0 50];
den = [1 1 0];
w = logspace(-1,2,100);
bode(num,den,w);
title('Bode Diagram of G1(s) = 50/[s(s+1)]')
    
```

Bode Diagram of  $G_1(s) = 50/[s(s+1)]$

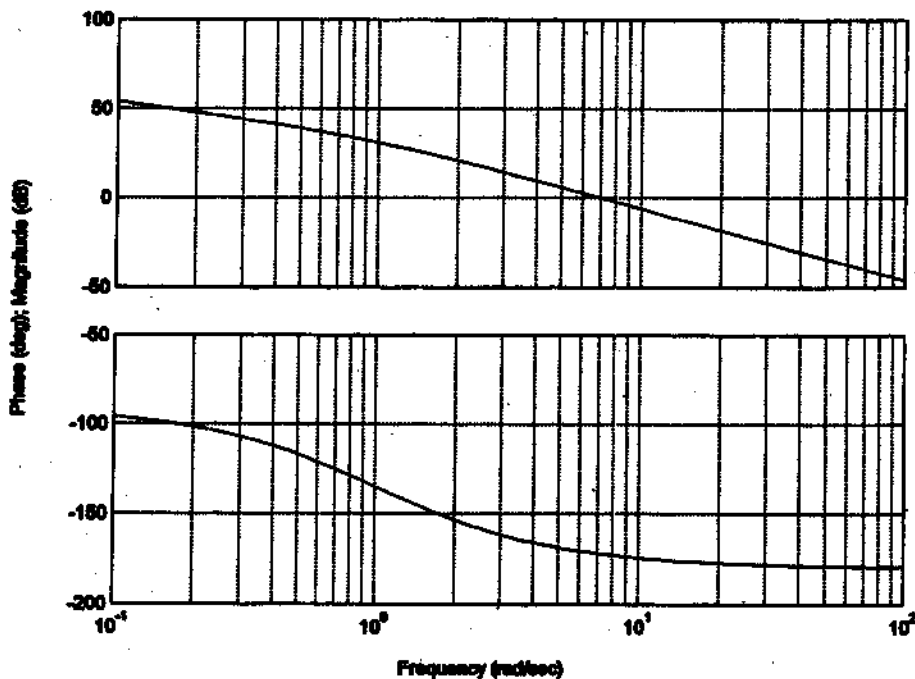

From this plot, the phase margin is found to be  $7.8^\circ$ . The gain margin is  $+\infty$  dB. Since the specifications call for a phase margin of  $50^\circ$ , the additional phase lead angle necessary to satisfy the phase margin requirement is  $42.2^\circ$ . We may assume the maximum phase lead required to be  $48^\circ$ . This means that  $5.8^\circ$  has been added to compensate for the shift in the gain crossover frequency. Since

$$\sin \phi_m = \frac{1-\alpha}{1+\alpha}$$

$\phi_m = 48^\circ$  corresponds to  $\alpha = 0.14735$ . (Note that  $\alpha = 0.15$  corresponds to  $\phi_m = 47.657^\circ$ .) Whether we choose  $\phi_m = 48^\circ$  or  $\phi_m = 47.657^\circ$  does not make much difference in the final solution. Hence, we choose  $\alpha = 0.15$ .

The next step is to determine the corner frequencies  $\omega = 1/T$  and  $\omega = 1/(\alpha T)$  of the lead compensator. Note that the maximum phase-lead angle  $\phi_m$  occurs at the geometric mean of the two corner frequencies, or  $\omega = 1/(\sqrt{\alpha}T)$ . The amount of the modification in the magnitude curve at  $\omega = 1/(\sqrt{\alpha}T)$  due to the inclusion of the term  $(Ts + 1)/(\alpha Ts + 1)$  is

$$\left| \frac{1+j\omega T}{1+j\omega\alpha T} \right|_{\omega=\frac{1}{\sqrt{\alpha}T}} = \left| \frac{1+j\frac{1}{\sqrt{\alpha}}}{1+j\alpha\frac{1}{\sqrt{\alpha}}} \right| = \frac{1}{\sqrt{\alpha}}$$

Note that

$$\frac{1}{\sqrt{\alpha}} = \frac{1}{\sqrt{0.15}} = 2.5820 = 8.239 \text{ dB}$$

We need to find the frequency point where, when the lead compensator is added, the total magnitude becomes 0 dB. The frequency at which the magnitude of  $G_1(j\omega)$  is equal to  $-8.239$  dB occurs between  $\omega = 10$  and  $100$  rad/sec. From the Bode diagram we find the frequency point where  $|G_1(j\omega)| = -8.239$  dB occurs at  $\omega = 11.4$  rad/sec. Noting that this frequency corresponds to  $1/(\sqrt{\alpha}T)$ , or

$$\omega_c = \frac{1}{\sqrt{\alpha}T}$$

we obtain

$$\frac{1}{T} = \omega_c \sqrt{\alpha} = 11.4 \sqrt{0.15} = 4.4152$$

$$\frac{1}{\alpha T} = \frac{\omega_c}{\sqrt{\alpha}} = \frac{11.4}{\sqrt{0.15}} = 29.4347$$

The lead compensator thus determined is

$$G_c(s) = K_c \frac{s + \frac{1}{T}}{s + \frac{1}{\alpha T}} = K_c \frac{s + 4.4152}{s + 29.4347}$$

where  $K_c$  is determined as

$$K_c = \frac{K}{\alpha} = \frac{50}{0.15} = \frac{1000}{3}$$

Thus,

$$G_c(s) = \frac{1000}{3} \frac{s + 4.4152}{s + 29.4347} = 50 \frac{0.2265s + 1}{0.03397s + 1}$$

The following MATLAB program produces the Bode diagram of the lead compensator just designed, as shown below.

```
% ***** Bode diagram *****
num1 = [11.325 50];
den1 = [0.03397 1];
w = logspace(-1,3,100);
bode(num1,den1,w);
title('Bode Diagram of Gc(s) = 50(0.2265s+1)/(0.03397s+1)')
```

Bode Diagram of Gc(s) = 50(0.2265s+1)/(0.03397s+1)

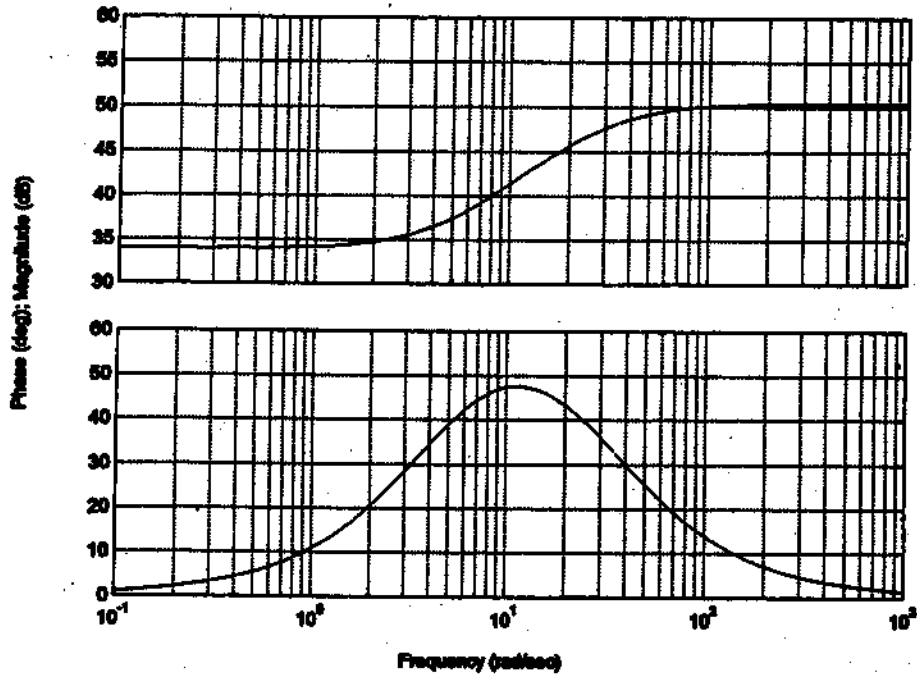

The open-loop transfer function of the designed system is

$$G_c(s)G(s) = \frac{1000}{3} \left( \frac{s + 4.4152}{s + 29.4347} \right) \frac{1}{s(s+1)}$$

The following MATLAB program produces the Bode diagram of  $G_c(s)G(s)$ , which is shown on the next page.

```
% ***** Bode diagram *****
num = [0 0 1000 4415.2];
den = [3 91.3041 88.3041 0];
w = logspace(-1,3,100);
bode(num,den,w);
title('Bode Diagram of Gc(s)G(s) = 1000(s+4.4152)/[3(s+29.4347)s(s+1)]')
```

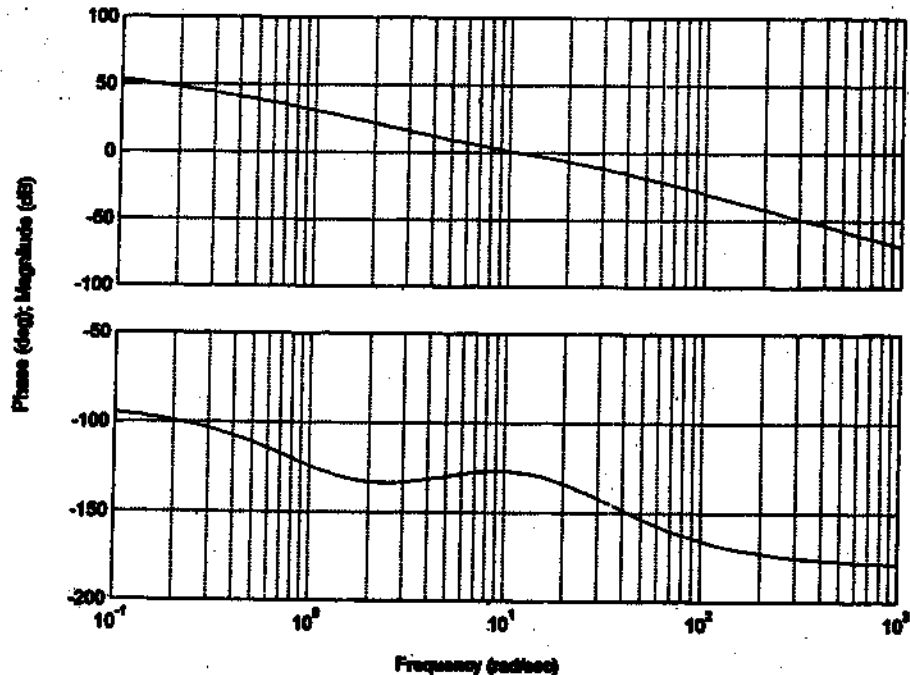

From this diagram, it is clearly seen that the phase margin is approximately  $52^\circ$ , the gain margin is  $+\infty$  dB, and  $K_v = 50 \text{ sec}^{-1}$ ; all specifications are met. Thus, the designed system is satisfactory.

Next, we shall obtain the unit-step and unit-ramp responses of the original uncompensated system and the compensated system. The original uncompensated system has the following closed-loop transfer function:

$$\frac{C(s)}{R(s)} = \frac{1}{s^2 + s + 1}$$

The closed-loop transfer function of the compensated system is

$$\begin{aligned} \frac{C(s)}{R(s)} &= \frac{1000(s + 4.4152)}{3(s + 29.4347)s(s + 1) + 1000(s + 4.4152)} \\ &= \frac{1000s + 4415.2}{3s^3 + 91.304s^2 + 1088.304s + 4415.2} \end{aligned}$$

The closed-loop poles of the compensated system are as follows:

$$s = -11.1772 + j7.5636$$

$$s = -11.1772 - j7.5636$$

$$s = -8.0804$$

The MATLAB program given at the top of next page produces the unit-step responses of the uncompensated and compensated systems. The resulting response curves are shown on the next page.

```

% ***** Unit-step response *****

num = [0 0 1];
den = [1 1 1];
numc = [0 0 1000 4415.2];
denc = [3 91.3041 1088.3041 4415.2];
t = 0:0.01:8;
c1 = step(num,den,t);
c2 = step(numc,denc,t);
plot(t,c1,t,c2)
title('Unit-Step Responses of Uncompensated and Compensated Systems')
xlabel('t Sec')
ylabel('Outputs')
text(1,1.25,'Compensated system')
text(2,0.5,'Uncompensated system')

```

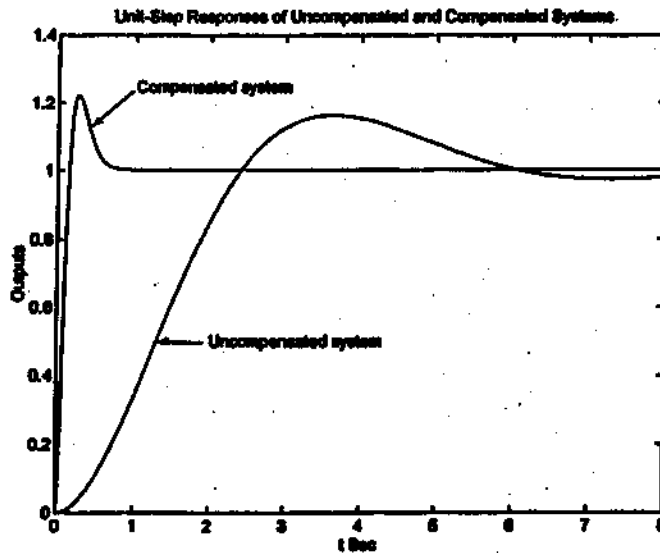

The MATLAB program given below produces the unit-ramp responses of the uncompensated system and compensated system. The response curves obtained are shown on the next page.

```

% ***** Unit-Ramp Response *****

num = [0 0 0 1];
den = [1 1 1 0];
numc = [0 0 0 1000 4415.2];
denc = [3 91.3041 1088.3041 4415.2 0];
t = 0:0.01:8;
c1 = step(num,den,t);
c2 = step(numc,denc,t);
plot(t,c1,t,c2,t)
title('Unit-Ramp Responses of Uncompensated and Compensated Systems')
xlabel('t Sec')
ylabel('Unit-Ramp Input and Outputs')
text(1,5,'Compensated system')
text(4,1.5,'Uncompensated system')

```

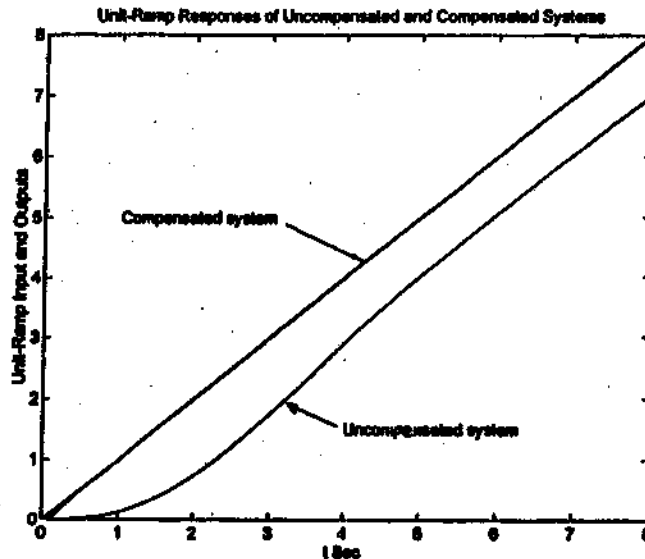

**B-9-7.** Since the plant does not have an integrator, it is necessary to add an integrator in the compensator. Let us choose the compensator to be

$$G_c(s) = \frac{K}{s} \hat{G}_c(s), \quad \lim_{s \rightarrow 0} \hat{G}_c(s) = 1$$

where  $\hat{G}_c(s)$  is to be determined later. Since the static velocity error constant is specified as  $4 \text{ sec}^{-1}$ , we have

$$K_v = \lim_{s \rightarrow 0} s G_c(s) \frac{s+0.1}{s^2+1} = \lim_{s \rightarrow 0} s \frac{K}{s} \hat{G}_c(s) \frac{s+0.1}{s^2+1} = 0.1 K = 4$$

Thus,  $K = 40$ . Hence

$$G_c(s) = \frac{40}{s} \hat{G}_c(s)$$

Next, we plot a Bode diagram of

$$G(s) = \frac{40(s+0.1)}{s(s^2+1)}$$

The following MATLAB program produces a Bode diagram of  $G(s)$ . See the Bode diagram shown on the next page.

```

% ***** Bode Diagram *****
num = [0 0 40 4];
den = [1 0.000000001 1 0];
bode(num,den)
title('Bode Diagram of 40(s+0.1)/[s(s^2+1)]')

```

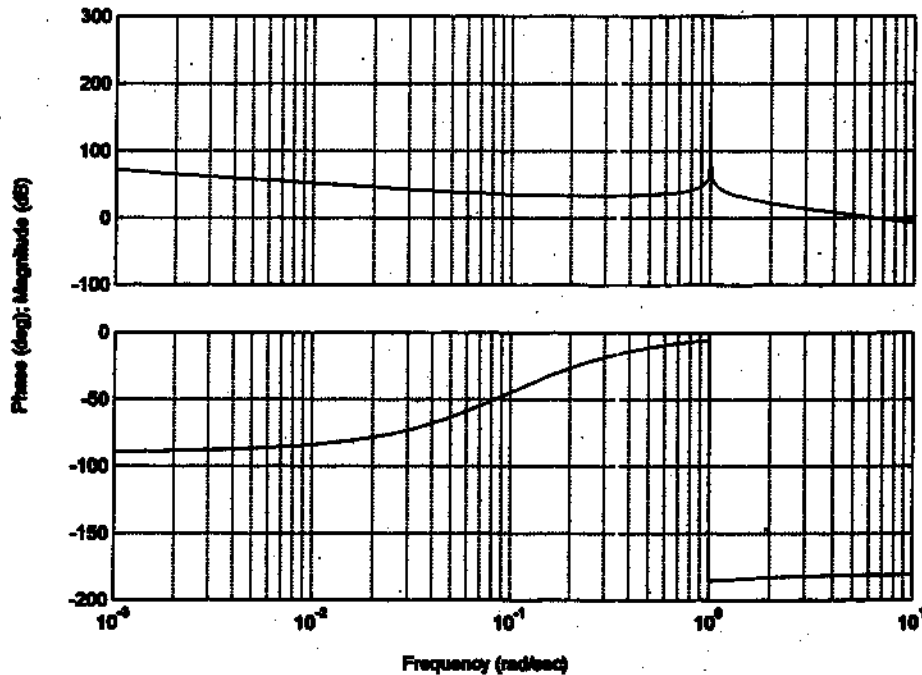
Bode Diagram of  $40(s+0.1)/(s^2+1)$ 

We need the phase margin of  $50^\circ$  and gain margin of 10 dB or more. Let us choose  $\hat{G}_c(s)$  to be

$$\hat{G}_c(s) = as + 1 \quad (a > 0)$$

Then  $G_c(s)$  will contribute up to  $90^\circ$  phase lead in the high frequency region.

By simple MATLAB trials, we find that  $a = 0.1526$  gives the phase margin of  $50^\circ$  and gain margin of  $+\infty$  dB. See the MATLAB program shown below and the resulting Bode diagram shown on the next page. From this Bode diagram we see that the static velocity error constant is  $4 \text{ sec}^{-1}$ , phase margin is  $50^\circ$  and gain margin is  $+\infty$  dB. Therefore, the designed system satisfies all the requirements.

```
% ***** Bode Diagram *****
num = conv([40 4],[0.1526 1]);
den = [1 0.000000001 1 0];
sys = tf(num,den);
w = logspace(-2,2,100);
bode(sys,w)
[Gm,pm,wcp,wcg] = margin(sys);
Gm dB = 20*log10(Gm);
[Gm dB, pm, wcp,wcg]

ans =

    Inf 50.0026    NaN  8.0114

title('Bode Diagram of G(s) = 40(s+0.1)(0.1526s+1)/(s^2+1)')
```

Bode Diagram of  $G(s) = 40(s+0.1)(0.1526s+1)/(s^2+1)$

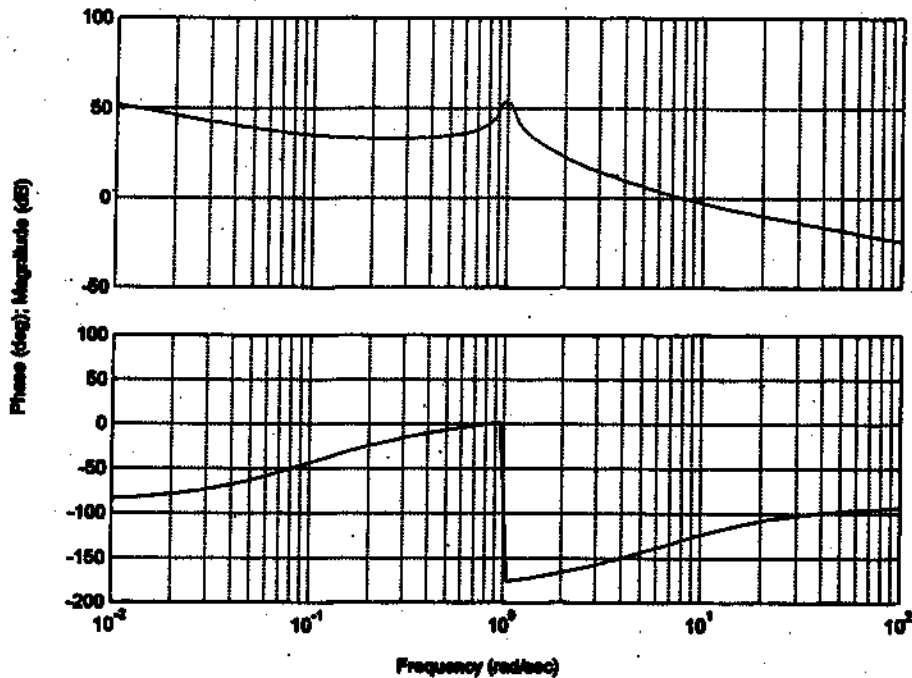

The designed compensator has the following transfer function:

$$G_c(s) = \frac{40}{s} \hat{G}_c(s) = \frac{40(0.1526s+1)}{s}$$

The open-loop transfer function of the designed system is

$$\begin{aligned} \text{Open-loop transfer function} &= \frac{40(0.1526s+1)}{s} \frac{s+0.1}{s^2+1} \\ &= \frac{6.104s^2 + 40.6104s + 4}{s(s^2+1)} \end{aligned}$$

We shall next check the unit-step response and the unit-ramp response of the designed system. The closed-loop transfer function is

$$\frac{C(s)}{R(s)} = \frac{6.104s^2 + 40.6104s + 4}{s^2 + 6.104s + 41.6104s + 4}$$

The closed-loop poles are located at

$$s = -3.0032 + j5.6573$$

$$s = -3.0032 - j5.6573$$

$$s = -0.0975$$

The following MATLAB program (shown on the next page) will produce the unit-step curve of the designed system. The resulting unit-step response curve is shown on the next page. Notice that the closed-loop pole at  $s = -0.0975$  and the plant zero at  $s = -0.1$  produce a long tail of small amplitude.

```
% ***** Unit-Step Response *****
```

```
num = [0 6.104 40.6104 4];  
den = [1 6.104 41.6104 4];  
t = 0:0.01:10;  
step(num,den,t)  
grid
```

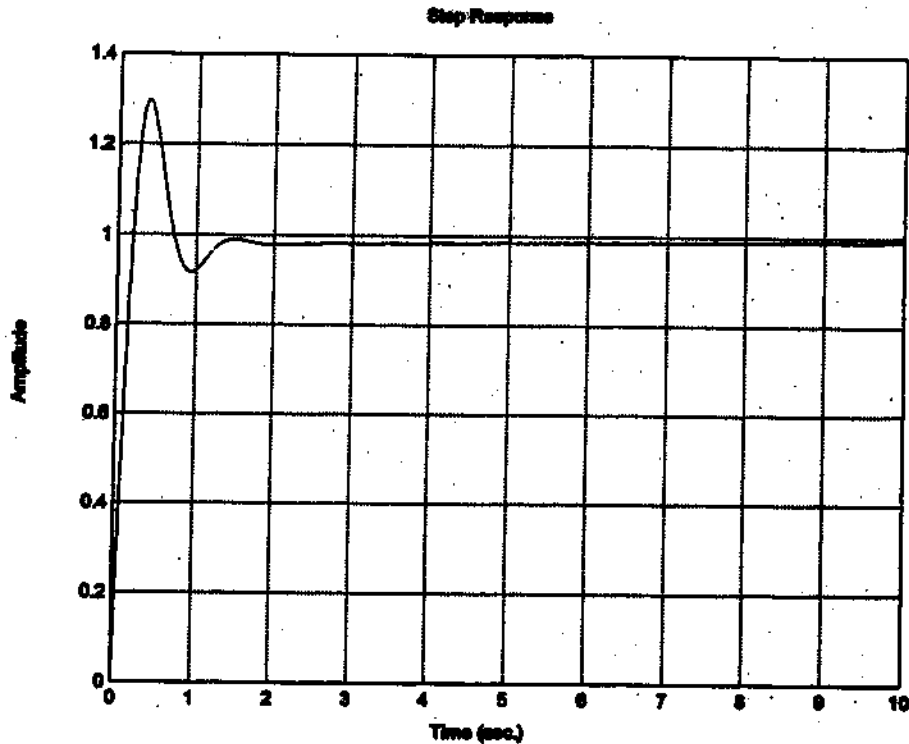

The following MATLAB program produces the unit-ramp response curve of the designed system. The resulting response curve is shown on the next page.

```
% ***** Unit-Ramp Response *****
```

```
num = [0 0 6.104 40.6104 4];  
den = [1 6.104 41.6104 4 0];  
t = 0:0.01:20;  
c = step(num,den,t);  
plot(t,c,'-','t','-')  
title('Unit-Ramp Response')  
xlabel('t (sec)')  
ylabel('Input Ramp Function and Output')  
text(3,14,'Input Ramp Function')  
text(13,10,'Output')
```

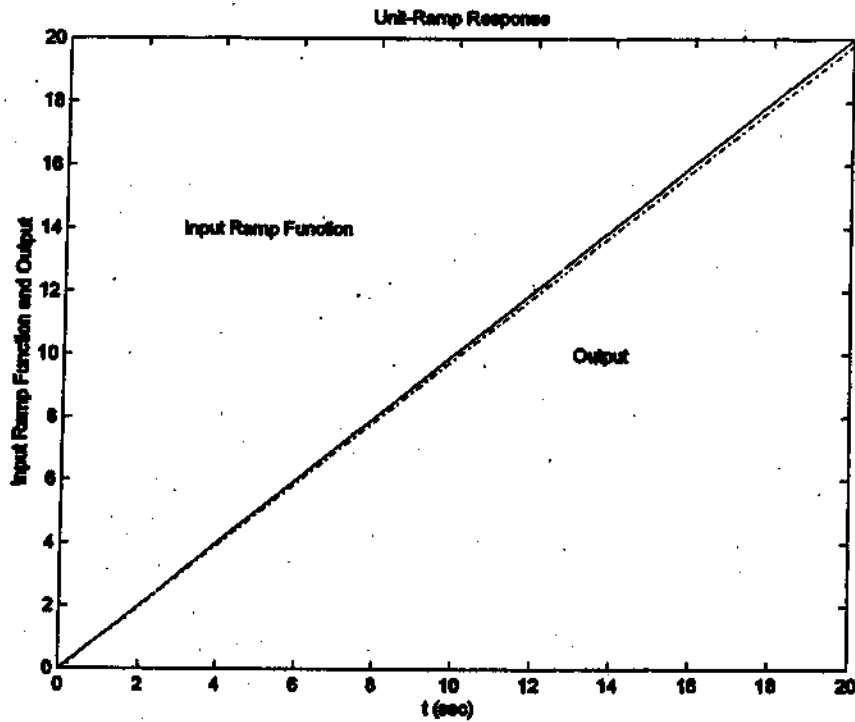

Nyquist plot: Define the open-loop transfer function as  $G(s)$ . Then

$$G(s) = G_c(s) \frac{s+0.1}{s^2+1} = \frac{6.104s^2 + 40.6104s + 4}{s(s^2+1)}$$

Let us choose a modified Nyquist path in the  $s$  plane as shown in Figure (a) below. The modified path encloses three open-loop poles ( $s = 0$ ,  $s = j1$ ,  $s = -j1$ ). Then the Nyquist path becomes as shown in Figure (b) below. In the  $s_1$  plane, the open-loop transfer function has three poles in the right-half  $s_1$  plane.

Let us choose  $\sigma_0 = 0.01$ . Since  $s = s_1 - \sigma_0$ , we have

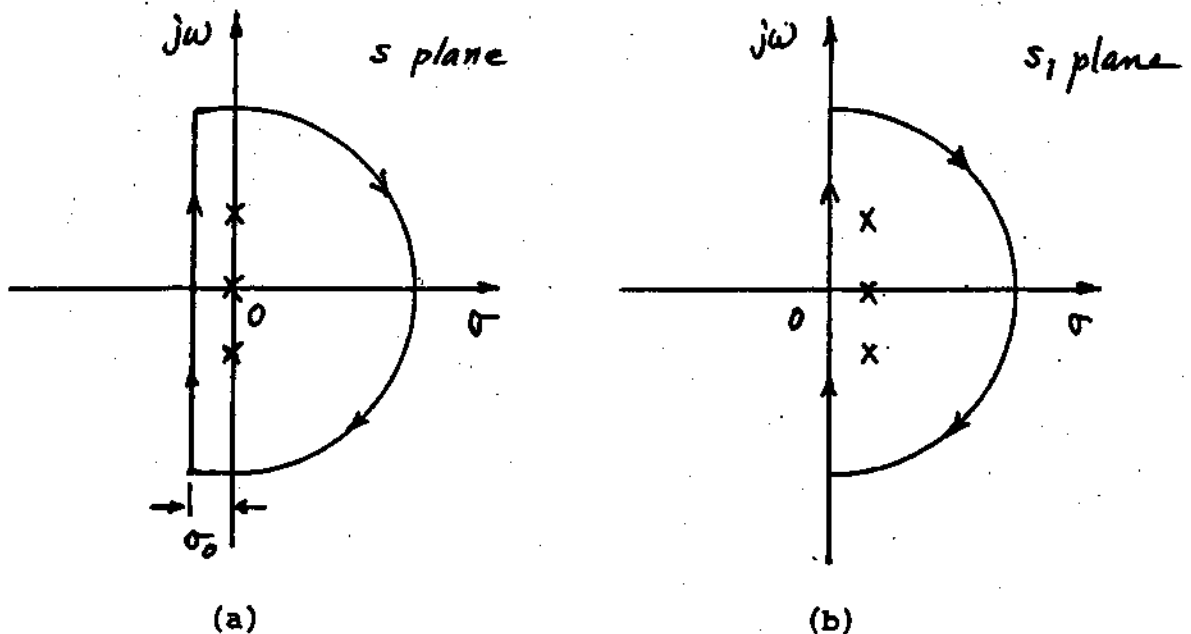

$$G(s) = G(s_1 - 0.01)$$

Open-loop transfer function in the  $s_1$  plane

$$= \frac{6.104 (s_1^2 - 0.02 s_1 + 0.0001) + 40.6104 (s_1 - 0.01) + 4}{(s_1 - 0.01) (s_1^2 - 0.02 s_1 + 1.0001)}$$

$$= \frac{6.104 s_1^2 + 40.48832 s_1 + 3.5945064}{s_1^3 - 0.03 s_1^2 + 1.0003 s_1 - 0.010001}$$

A MATLAB program to obtain the Nyquist plot is shown below. The resulting Nyquist plot is shown below.

```
% ***** Nyquist Plot *****
num = [0 6.104 40.48832 3.5945064];
den = [1 -0.03 1.0003 -0.010001];
nyquist(num,den)
v = [-1500 1500 -2500 2500]; axis(v)
```

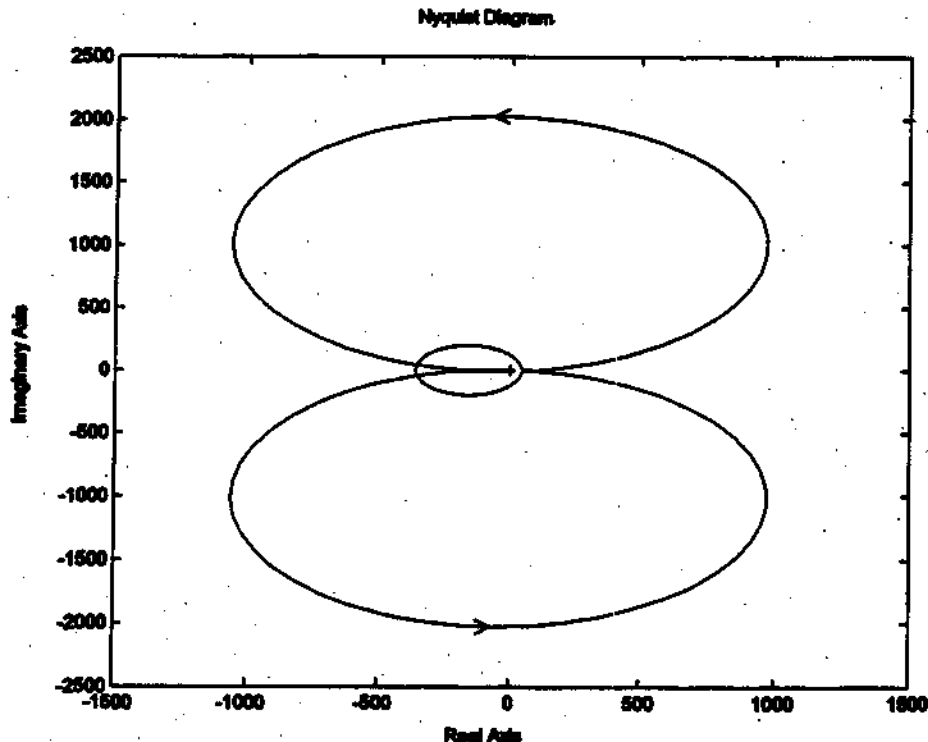

The Nyquist plot obtained here is not easy to determine the encirclement of the  $-1 + j0$  point by the Nyquist locus. Therefore, we need to redraw this Nyquist plot qualitatively to show the details near the  $-1 + j0$  point. Such a redrawn Nyquist diagram is shown on the next page.

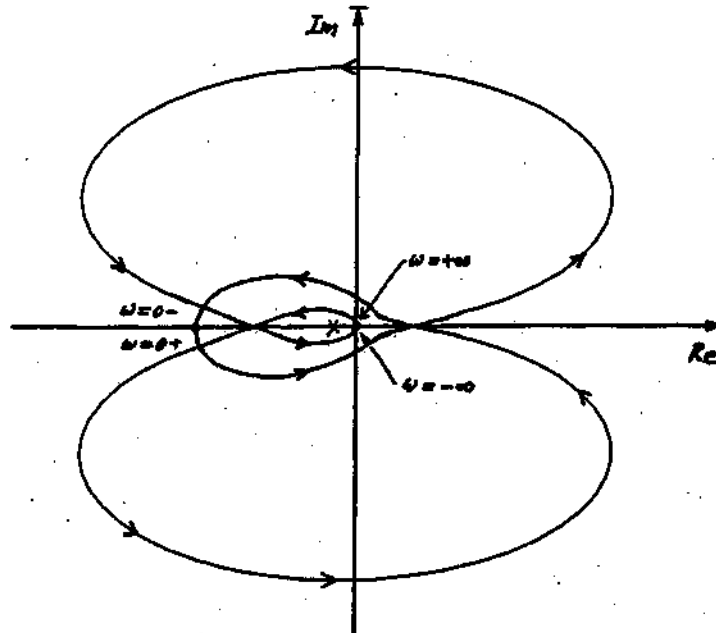

From this diagram we find that the  $-1 + j0$  point is encircled counterclockwise three times. Hence,  $N = -3$ . Since the open-loop transfer function has three poles in the right-half  $s_1$  plane, we have  $P = 3$ . Then, we have  $Z = N + P = 0$ . This means that there are no closed-loop poles in the right-half  $s_1$  plane. The system is therefore stable.

B-9-8. The plant transfer function is

$$G(s) = \frac{2s + 0.1}{s(s^2 + 0.1s + 4)}$$

The plant involves a quadratic term with  $\zeta = 0.025$ . This term is quite oscillatory. MATLAB program shown below produces the Bode diagram of  $G(s)$  as shown on the next page.

```

% **** Bode diagram ****
num = [0 0 2 0.1];
den = [1 0.1 4 0];
w = logspace(-3,2,100);
bode(num,den,w);
title('Bode Diagram of G(s) = (2s+0.1)/(s^2+0.1s+4)')

```

The closed-loop transfer function of the original uncompensated system is

$$\frac{C(s)}{R(s)} = \frac{2s + 0.1}{s^3 + 0.1s^2 + 6s + 0.1}$$

The closed-loop poles of the uncompensated system are

$$\begin{aligned}
 s &= -0.0417 + j2.4489 \\
 s &= -0.0417 - j2.4489 \\
 s &= -0.0167
 \end{aligned}$$

Bode Diagram of  $G(s) = (2s+0.1)/(s^2+0.1s+4)$

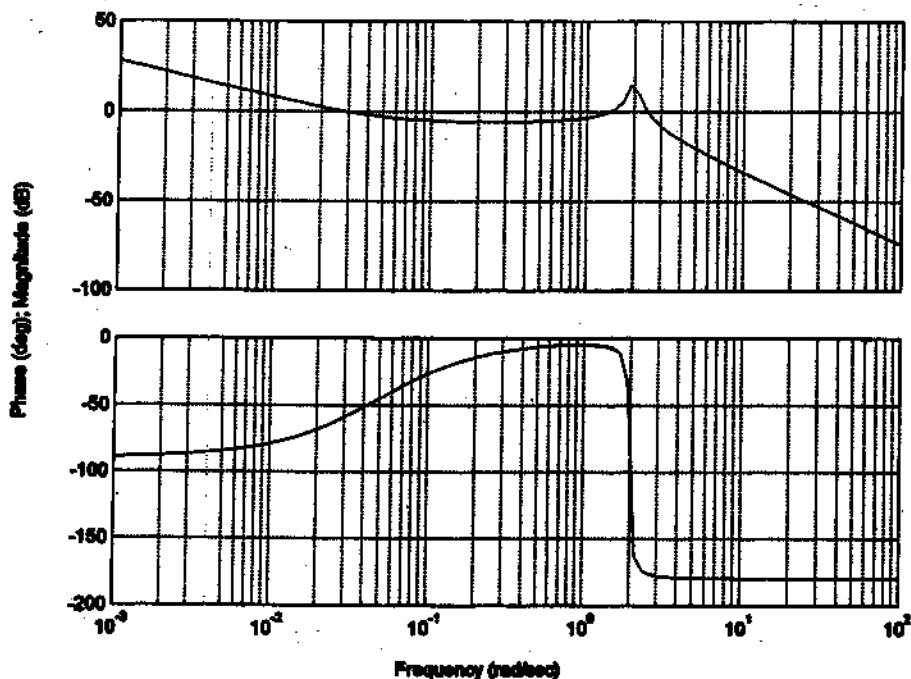

The unit-step response of this original, uncompensated system is obtained by entering the following MATLAB program into the computer. The resulting unit-step response curve is shown below.

```

% ***** Unit-step response *****
num = [0 0 2 0.1];
den = [1 0.1 6 0.1];
step(num,den)
grid
title('Unit-Step Response of Uncompensated System')
    
```

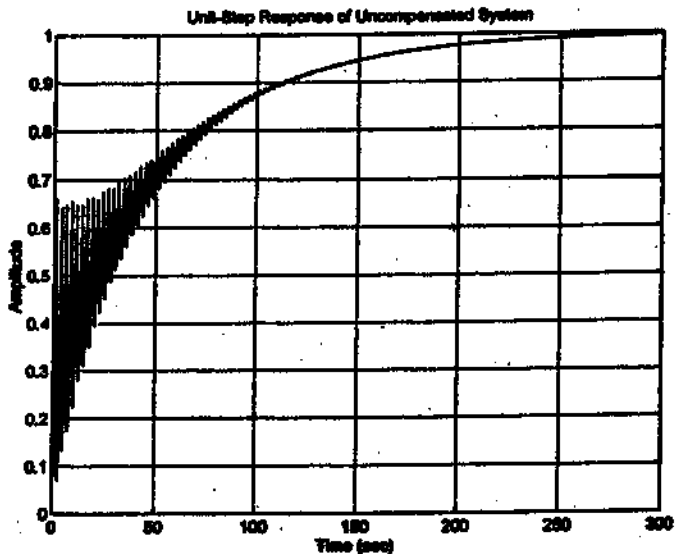

To design a compensator for such a system, it is desirable to cancel the zero of the plant, since it is located very close to the origin. It is sometimes useful to include double zero and double pole in the compensator. So, we may choose the compensator to be

$$G_c(s) = K_c \frac{(s+2)^2}{(s+10)^2} \frac{s+a}{2s+0.1}$$

where we have chosen the double zero at  $s = -2$  and double pole at  $s = -10$ . The value of  $a$  is determined later. Since the static velocity error constant is specified as  $4 \text{ sec}^{-1}$ , we have

$$\begin{aligned} K_v &= \lim_{s \rightarrow 0} s G_c(s) G(s) = \lim_{s \rightarrow 0} s K_c \frac{(s+2)^2}{(s+10)^2} \frac{s+a}{2s+0.1} \frac{2s+0.1}{s(s^2+0.1s+4)} \\ &= K_c \frac{a}{100} = 4 \end{aligned}$$

Hence,

$$K_c a = 400$$

By several MATLAB trials we find  $a = 4$  will give a satisfactory result. Therefore, we choose  $a = 4$  and  $K_c = 100$ . Then, the transfer function of the compensator becomes

$$G_c(s) = 100 \frac{(s+2)^2}{(s+10)^2} \frac{s+4}{2s+0.1}$$

The open-loop transfer function becomes as follows:

$$\begin{aligned} G_c(s) G(s) &= \frac{100 (s+2)^2 (s+4)}{(s+10)^2 s (s^2+0.1s+4)} \\ &= \frac{100 s^3 + 800 s^2 + 2000s + 1600}{s^5 + 20.1s^4 + 106s^3 + 90s^2 + 400s} \end{aligned}$$

The following MATLAB program produces a Bode diagram of  $G_c(s)G(s)$ . The resulting Bode diagram is shown on the next page.

```
% ***** Bode diagram *****
num = [0 0 100 800 2000 1600];
den = [1 20.1 106 90 400 0];
w = logspace(-1,2,100);
bode(num,den,w);
title('Bode Diagram of 100(s+2)^2(s+4)/[(s+10)^2s(s^2+0.1s+4)]')
```

From this Bode diagram, it is seen that  $K_v = 4 \text{ sec}^{-1}$ , phase margin is approximately  $50^\circ$  and gain margin is  $+\infty \text{ dB}$ . So, all the requirements are met.

Bode Diagram of  $100(s+2)^2(s+4)/(s+10)^2(s^2+0.1s+4)$

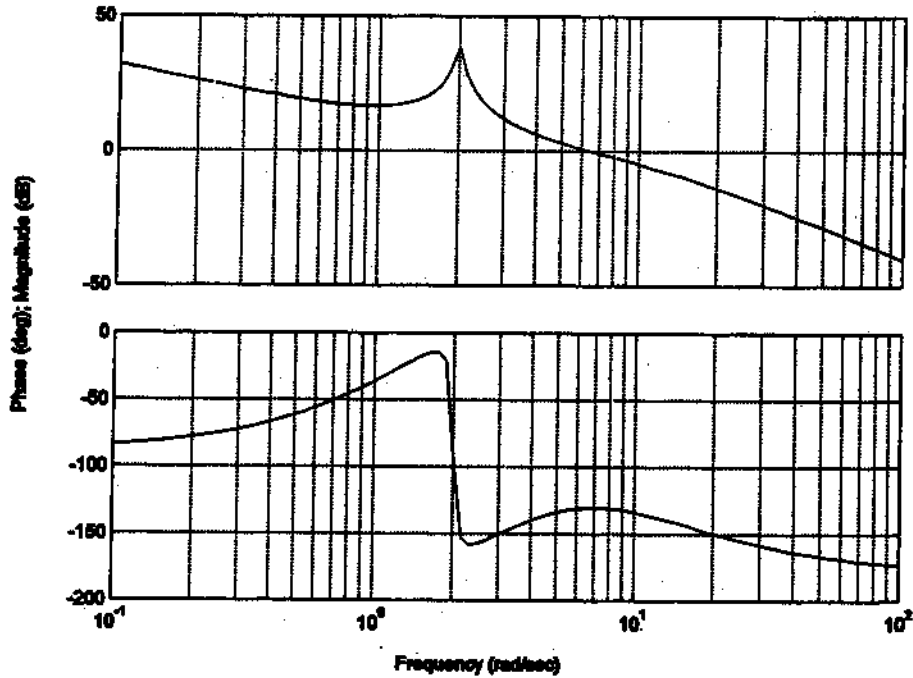

The closed-loop transfer function of the compensated system becomes as follows:

$$\frac{C(s)}{R(s)} = \frac{100s^3 + 800s^2 + 2000s + 1600}{s^5 + 20.1s^4 + 206s^3 + 890s^2 + 2400s + 1600}$$

The closed-loop poles of the compensated system can be found as follows.

```
denc = [1 20.1 206 890 2400 1600];
roots(denc)

ans =
-7.3481 + 7.2145i
-7.3481 - 7.2145i
-2.2424 + 3.3751i
-2.2424 - 3.3751i
-0.9189
```

The following MATLAB program produces the unit-step response of the designed system.

```
% ***** Unit-step response *****

numc = [0 0 100 800 2000 1600];
denc = [1 20.1 206 890 2400 1600];
step(numc,denc)
grid
title('Unit-Step Response of Compensated System (Problem B-9-8)')
```

The unit-step response curve is shown below.

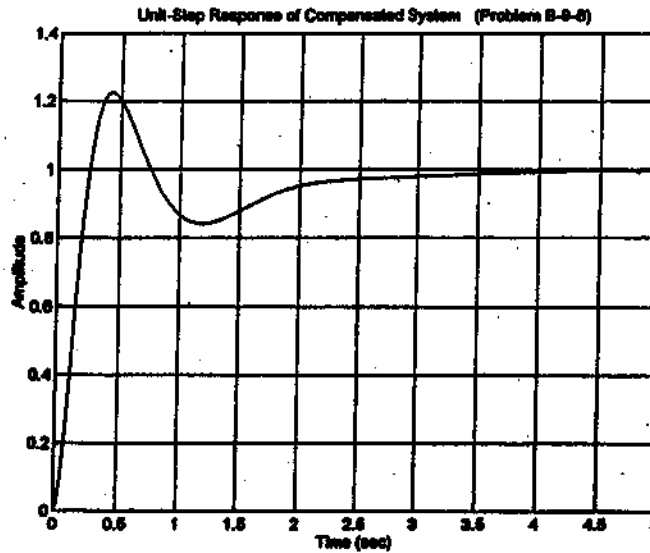

The following MATLAB program will produce the unit-ramp response of the compensated system.

```

% ***** Unit-ramp response *****
numc = [0 0 0 100 800 2000 1600];
denc = [1 20.1 206 890 2400 1600 0];
t = 0:0.02:10;
c = step(numc,denc,t);
plot(t,c,'-','t,t','--')
title('Unit-Ramp Response of Compensated System (Problem B-9-8)')
xlabel('t (Sec)')
ylabel('Output and Input Ramp')
text(5,3,'Compensated system')

```

The unit-ramp response curve is shown below.

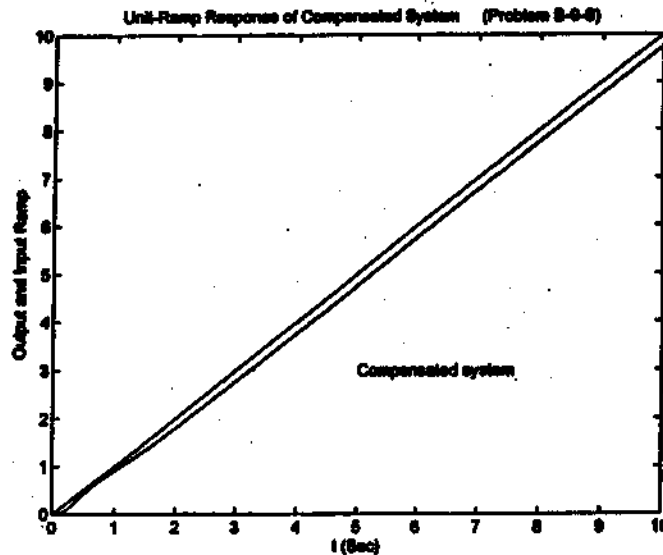

It is noted that there are infinitely many possible compensators for this system. A few possible compensators are shown below.

$$G_c(s) = 400 \frac{(s+1)^2}{(s+25)(2s+0.1)}$$

$$G_c(s) = 320 \frac{(s+1)^2}{(s+20)(2s+0.1)}$$

$$G_c(s) = 160 \frac{s+8}{s+30} \frac{s+1}{s+0.1333}$$

$$G_c(s) = 1212.12 \frac{s+9.81}{s+79.32}$$

B-9-9. Let us assume that the compensator  $G_c(s)$  has the following form:

$$G_c(s) = K_c \frac{(T_1s+1)(T_2s+1)}{\left(\frac{T_1}{\beta}s+1\right)(\beta T_2s+1)} = K_c \frac{\left(s+\frac{1}{T_1}\right)\left(s+\frac{1}{T_2}\right)}{\left(s+\frac{\beta}{T_1}\right)\left(s+\frac{1}{\beta T_2}\right)}$$

Since  $K_v$  is specified as  $20 \text{ sec}^{-1}$ , we have

$$K_v = \lim_{s \rightarrow 0} s G_c(s) \frac{1}{s(s+1)(s+5)} = K_c \frac{1}{5} = 20$$

Hence

$$K_c = 100$$

Define

$$G_1(s) = 100 G(s) = \frac{100}{s(s+1)(s+5)}$$

The following MATLAB program produces the Bode diagram of  $G_1(s)$  as shown on the next page.

```
% ***** Bode diagram *****
num = [0 0 0 100];
den = [1 6 5 0];
w = logspace(-2,3,100);
bode(num,den,w);
title('Bode Diagram of G1(s) = 100/[s(s+1)(s+5)]')
```

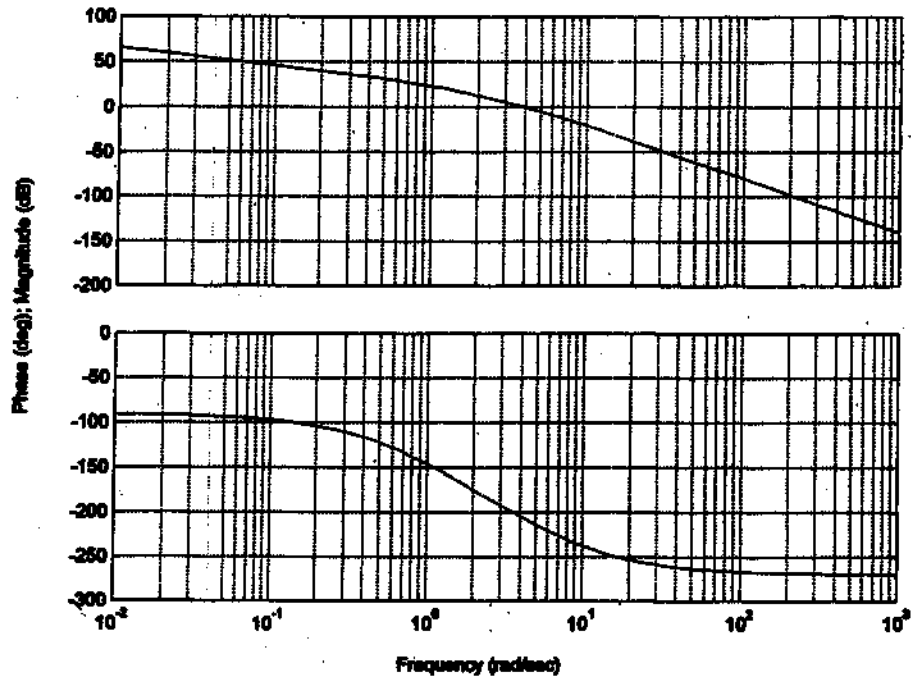

From this diagram we find the phase crossover frequency to be  $\omega = 2.25$  rad/sec. Let us choose the gain crossover frequency of the designed system to be 2.25 rad/sec so that the phase lead angle required at  $\omega = 2.25$  rad/sec is  $60^\circ$ .

Once we choose the gain crossover frequency to be 2.25 rad/sec, we can determine the corner frequencies of the phase lag portion of the lag-lead compensator. Let us choose the corner frequency  $1/T_2$  to be one decade below the new gain crossover frequency, or  $1/T_2 = 0.225$ . For the lead portion of the compensator, we first determine the value of  $\beta$  that provides  $\phi_m = 65^\circ$ . ( $5^\circ$  added to  $60^\circ$ .) Since

$$\sin \phi_m = \frac{1 - \frac{1}{\beta}}{1 + \frac{1}{\beta}} = \frac{\beta - 1}{\beta + 1}$$

we find  $\beta = 20$  corresponds to  $64.7912^\circ$ . Since we need  $65^\circ$  phase margin, we may choose  $\beta = 20$ . Thus

$$\beta = 20$$

Then, the corner frequency  $1/(\beta T_2)$  of the phase lag portion becomes as follows:

$$\frac{1}{\beta T_2} = \frac{1}{20 \times \frac{1}{0.225}} = \frac{0.225}{20} = 0.01125$$

Hence, the phase lag portion of the compensator becomes as

$$\frac{s + 0.225}{s + 0.01125} = 20 \frac{4.4444s + 1}{88.8889s + 1}$$

For the phase lead portion, we first note that

$$G_1(j2.25) = 10.35 \text{ dB}$$

If the lag-lead compensator contributes  $-10.35 \text{ dB}$  at  $\omega = 2.25 \text{ rad/sec}$ , then the new gain crossover frequency will be as desired. The intersections of the line with slope  $+20 \text{ dB/dec}$  [passing through the point  $(2.25, -10.35 \text{ dB})$ ] and the  $0 \text{ dB}$  line and  $-26.0206 \text{ dB}$  line determine the corner frequencies. Such intersections are found as  $\omega = 0.3704$  and  $\omega = 7.4077 \text{ rad/sec}$ , respectively. Thus, the phase lead portion becomes

$$\frac{s + 0.3704}{s + 7.4077} = \frac{1}{20} \left( \frac{2.6998s + 1}{0.1350s + 1} \right)$$

Hence the compensator can be written as

$$\begin{aligned} G_c(s) &= 100 \left( \frac{4.4444s + 1}{88.8889s + 1} \right) \left( \frac{2.6998s + 1}{0.1350s + 1} \right) \\ &= 100 \left( \frac{s + 0.225}{s + 0.01125} \right) \left( \frac{s + 0.3704}{s + 7.4077} \right) \end{aligned}$$

Then the open-loop transfer function  $G_c(s)G(s)$  becomes as follows:

$$\begin{aligned} G_c(s)G(s) &= 100 \left( \frac{4.4444s + 1}{88.8889s + 1} \right) \left( \frac{2.6998s + 1}{0.1350s + 1} \right) \frac{1}{s(s+1)(s+5)} \\ &= \frac{1199.90s^2 + 714.42s + 100}{12s^5 + 161.0239s^4 + 595.1434s^3 + 451.1195s^2 + 5s} \end{aligned}$$

The following MATLAB program produces the Bode diagram of the open-loop transfer function.

```

% **** Bode diagram ****
num = [0 0 0 1199.90 714.42 100];
den = [12 161.0239 595.1434 451.1195 5 0];
w = logspace(-3,3,100);
bode(num,den,w);
title('Bode Diagram of Compensated System')

```

The resulting Bode diagram is shown on the next page.

Bode Diagram of Compensated System

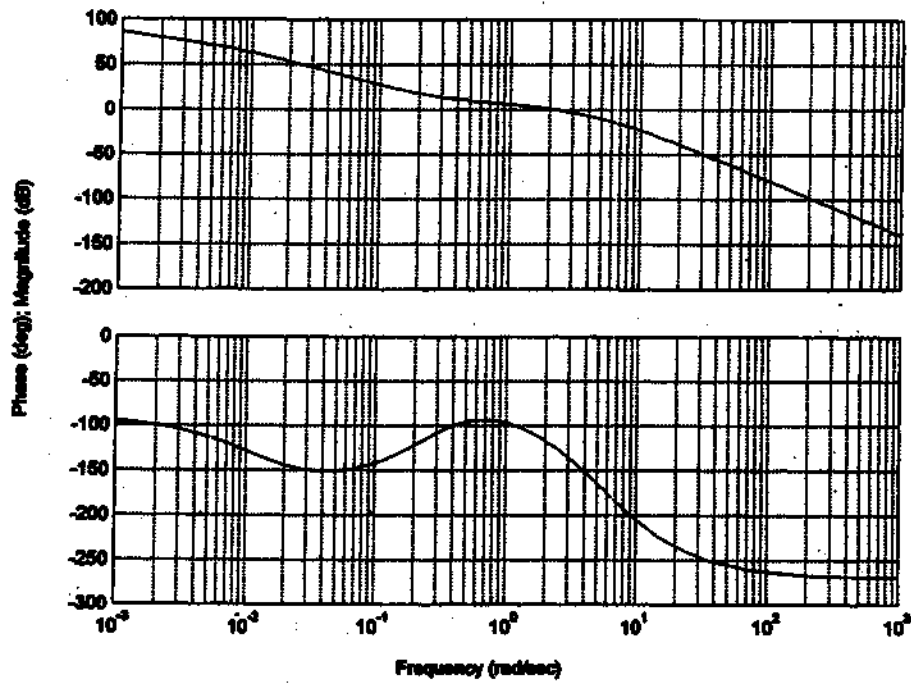

To read the phase margin and gain margin precisely, we need to expand the diagram between  $\omega = 1$  and  $\omega = 10$  rad/sec. This can be done easily by modifying the preceding MATLAB program. [Simply change the command `w = logspace(-3,3,100)` to `w = logspace(0,1,100)`.] The resulting Bode diagram is shown below.

Bode Diagram of Compensated System

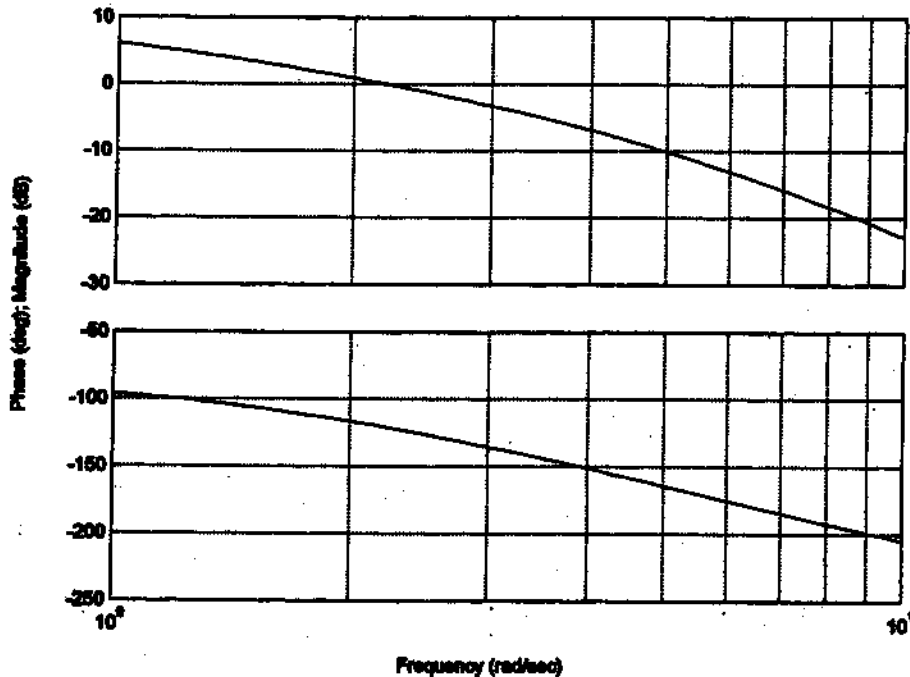

From this diagram we find that the phase margin is approximately  $60^\circ$  and gain margin is 14.35 dB. The static velocity error constant is  $20 \text{ sec}^{-1}$ .

The closed-loop transfer function of the designed system is

$$\frac{C(s)}{R(s)} = \frac{1199.90 s^2 + 714.42 s + 100}{12 s^5 + 161 s^4 + 595.1 s^3 + 1651 s^2 + 719.4 s + 100}$$

The following MATLAB program produces the unit-step response. The resulting unit-step response curve is shown below.

```
% ***** Unit-step response *****  
numc = [0 0 0 1199.90 714.42 100];  
denc = [12 161 595.1 1651 719.4 100];  
step(numc,denc)  
grid  
title('Unit-Step Response of Compensated System')
```

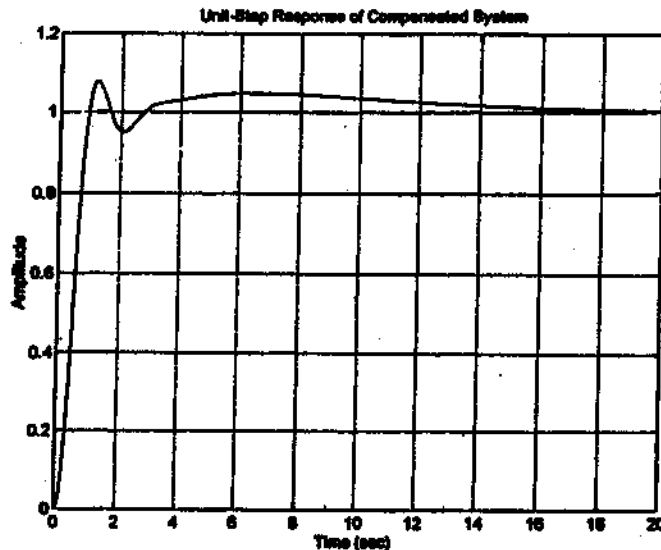

The closed-loop poles can be obtained by entering the following MATLAB program into the computer.

```
roots(denc)  
  
ans =  
  
-9.7022  
-1.6110 + 3.0494i  
-1.6110 - 3.0494i  
-0.2463 + 0.1076i  
-0.2463 - 0.1076i
```

Notice that there are two zeros ( $s = -0.225$  and  $s = -0.4939$ ) near the closed-loop poles at  $s = -0.2463 \pm j0.1076$ . Such a pole-zero combination generates a long tail with small amplitude in the unit-step response.

The following MATLAB program will produce the unit-ramp response as shown below.

```
% ***** Unit-ramp response *****  
numc = [0 0 0 0 1199.90 714.42 100];  
denc = [12 161 595.1 1651 719.4 100 0];  
t = 0:0.05:20;  
c = step(numc,denc,t);  
plot(t,c,'-',t,t,':')  
grid  
title('Unit-Ramp Response of Compensated System')  
xlabel('t Sec')  
ylabel('Output and Ramp Input')  
text(11,7,'Output'); text(1,7,'Ramp Input')
```

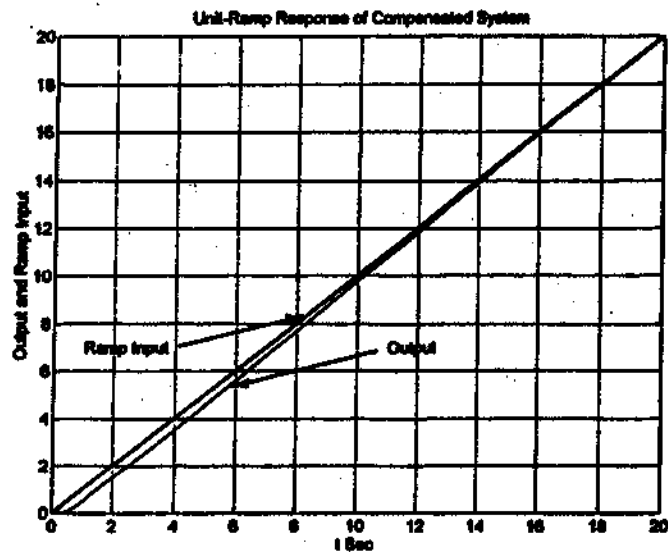

# CHAPTER 10

**B-10-1.** Referring to Equation (3-76), we have

$$K_p = \frac{R_2 (R_1 C_1 + R_2 C_2)}{R_3 R_1 C_2} = 39.42$$

$$T_i = R_1 C_1 + R_2 C_2 = 3.077$$

$$T_d = \frac{R_1 C_1 R_2 C_2}{R_1 C_1 + R_2 C_2} = 0.7692$$

First, notice that

$$(R_1 C_1) + (R_2 C_2) = 3.077$$

$$(R_1 C_1)(R_2 C_2) = 0.7692 \times 3.077 = 2.3668$$

Hence we obtain

$$R_1 C_1 = 1.5385, \quad R_2 C_2 = 1.5385$$

Since we have six unknown variables and three equations, we can choose three variables arbitrarily. So we choose  $C_1 = C_2 = 10 \mu\text{F}$  and one remaining variable later. Then we get

$$R_1 = R_2 = 153.85 \text{ k}\Omega$$

From the equation for  $K_p$ , we have

$$\frac{R_2}{R_3} \frac{R_1 C_1 + R_2 C_2}{R_1 C_2} = 39.42$$

or

$$\frac{R_2}{R_3} = 39.42 \times \frac{1}{2} = 19.71$$

We now choose arbitrarily  $R_3 = 10 \text{ k}\Omega$ . Then,  $R_4 = 197.1 \text{ k}\Omega$ . The PID controller obtained is shown below.

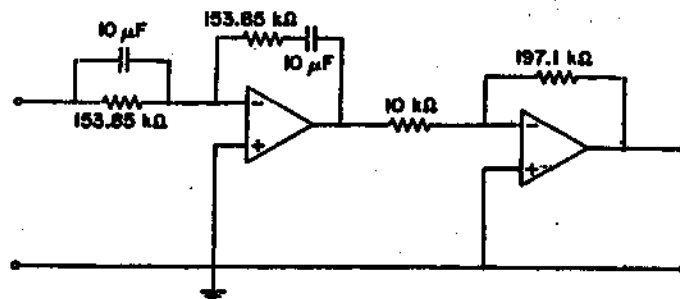

**B-10-2.** For the reference input, the closed-loop transfer function is

$$\frac{C(s)}{R(s)} = \frac{2K(a s + 1)(b s + 1)(s + 2)}{s(s + 1)(s + 10) + 2K(a s + 1)(b s + 1)(s + 2)}$$

Notice that the numerator is a polynomial in  $s$  of degree 3 and the denominator is also a polynomial in  $s$  of degree 3. In such a case, it is advisable to reduce the degree of numerator polynomial by one by choosing  $a = 0$ . Then the closed-loop transfer function becomes

$$\frac{C(s)}{R(s)} = \frac{2K(b s + 1)(s + 2)}{s(s + 1)(s + 10) + 2K(b s + 1)(s + 2)}$$

Let us choose the value of  $b$  to be 0.5 so that the zero of the controller is located at  $s = -2$ . Then, the controller transfer function  $G_c(s)$  becomes

$$G_c(s) = \frac{K(0.5s + 1)}{s} = \frac{0.5K(s + 2)}{s}$$

Then

$$\frac{C(s)}{R(s)} = \frac{K(s + 2)^2}{s(s + 1)(s + 10) + K(s + 2)^2}$$

The closed-loop transfer function for the disturbance input becomes as

$$\frac{C_D(s)}{D(s)} = \frac{2s(s + 2)}{s(s + 1)(s + 10) + K(s + 2)^2}$$

The requirement on the response to the step disturbance input is that the response should attenuate rapidly. Let us interpret this requirement to be the settling time of 2 sec. By a simple MATLAB trial-and-error approach on the value of  $K$ , we find that  $K = 20$  gives the settling time to be 2 sec. So we choose  $K = 20$ . With  $K = 20$ , the closed-loop transfer function  $C_D(s)/D(s)$  for the disturbance input becomes

$$\frac{C_D(s)}{D(s)} = \frac{2s^2 + 4s}{s^3 + 31s^2 + 90s + 80}$$

The following MATLAB program produces the response to the unit-step disturbance input. The resulting response curve is shown on the next page.

```
% ***** Unit-step response (Disturbance input) *****
numd = [0 2 4 0];
dend = [1 31 90 80];
step(numd,dend)
grid
title('Unit-Step Response (Disturbance Input)')
```

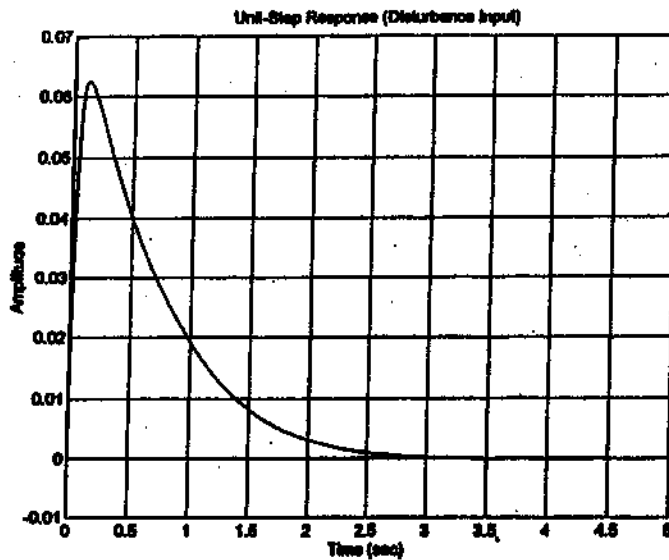

This response curve corresponds to the settling time of 2 sec. This may not be obvious. Therefore, we plot the response to the unit-ramp disturbance input. The following MATLAB is used to obtain the unit-ramp response.

```
% ***** Unit-ramp response (Disturbance input) *****
numdd = [0 0 2 4 0];
dendd = [1 31 90 80 0];
step(numdd,dendd)
grid
title('Unit-Ramp Response (Disturbance Input)')
```

The resulting response curve is shown below.

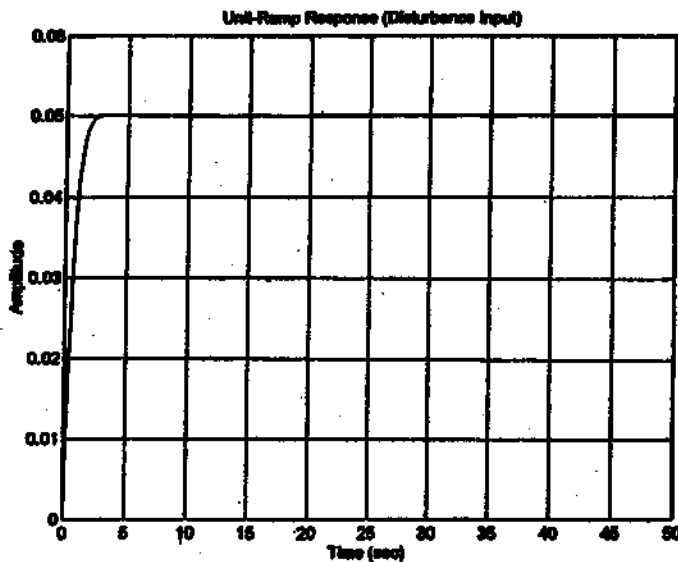

The settling time can be seen to be approximately 2 sec.

For the reference input, the closed-loop transfer function with  $K = 20$  is

$$\frac{C(s)}{R(s)} = \frac{20s^2 + 80s + 80}{s^3 + 31s^2 + 90s + 80}$$

The MATLAB program below produces the unit-step response curve for the reference input, as shown below.

```
% ***** Unit-step response (Reference Input) *****  
numr = [0 20 80 80];  
denr = [1 31 90 80];  
step(numr,denr)  
grid  
title('Unit-Step Response (Reference Input)')
```

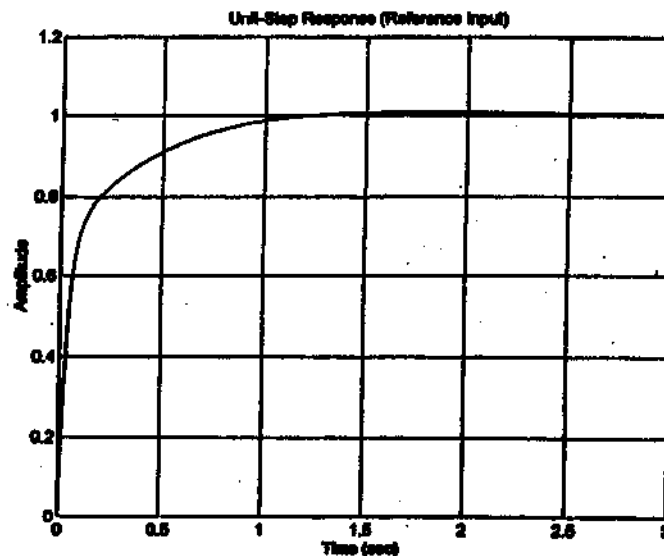

From this plot, we see that the settling time for the reference input is 2 sec. The closed-loop poles for the system are shown in the MATLAB output shown below.

```
roots(denr)  
  
ans =  
-27.8742  
-1.5629 + 0.6537i  
-1.5629 - 0.6537i
```

The designed controller is

$$G_c(s) = \frac{20(0.5s+1)}{s} = \frac{10(s+2)}{s}$$

**B-10-3.** The closed-loop transfer function of the system shown in Figure 10-58 (a) is

$$\frac{C(s)}{R(s)} = \frac{K_p \left(1 + \frac{1}{T_i s} + T_d s\right) G_p(s)}{1 + K_p \left(1 + \frac{1}{T_i s} + T_d s\right) G_p(s)} \quad (1)$$

The closed-loop transfer function of the system shown in Figure 10-58 (b) can be obtained as follows: Define the input to the block  $G_p(s)$  as  $U(s)$ . Then,

$$U(s) = K_p (1 + T_d s) R(s) + \frac{K_p}{T_i s} [R(s) - C(s)] - K_p (1 + T_d s) C(s)$$

Also, we have

$$C(s) = G_p(s) U(s)$$

Hence

$$\frac{C(s)}{G_p(s)} = K_p \left(1 + \frac{1}{T_i s} + T_d s\right) R(s) - K_p \left(1 + \frac{1}{T_i s} + T_d s\right) C(s)$$

from which we obtain

$$\frac{C(s)}{R(s)} = \frac{K_p \left(1 + \frac{1}{T_i s} + T_d s\right) G_p(s)}{1 + K_p \left(1 + \frac{1}{T_i s} + T_d s\right) G_p(s)}$$

This last equation is the same as Equation (1). Thus, the two systems are equivalent.

**B-10-4.** We shall first obtain the closed-loop transfer function  $C(s)/R(s)$  of the I-PD controlled system. In the absence of the disturbance  $D(s)$ , the minor loop has the following transfer function:

$$\frac{C(s)}{U(s)} = \frac{39.42}{s(s+1)(s+5) + 39.42(1+0.7692s)}$$

where  $U(s)$  is the input to the minor loop. The open-loop transfer function  $G(s)$  of the system is

$$\begin{aligned} G(s) &= \frac{1}{3.0775} \left[ \frac{39.42}{s(s+1)(s+5) + 39.42(1+0.7692s)} \right] \\ &= \frac{12.8112}{s^3 + 6s^2 + 35.3219s + 39.425} \end{aligned}$$

The closed-loop transfer function is

$$\frac{C(s)}{R(s)} = \frac{12.8112}{s^2 + 6s^2 + 35.3219s^2 + 39.425s + 12.8112}$$

The following MATLAB program produces the unit-step response. The resulting response curve is shown below.

```
% ***** Unit-step response *****  
num = [0 0 0 0 12.8112];  
den = [1 6 35.3219 39.42 12.8112];  
t = 0:0.05:30;  
step(num,den,t)  
grid  
title('Unit-Step Response of I-PD controlled System')
```

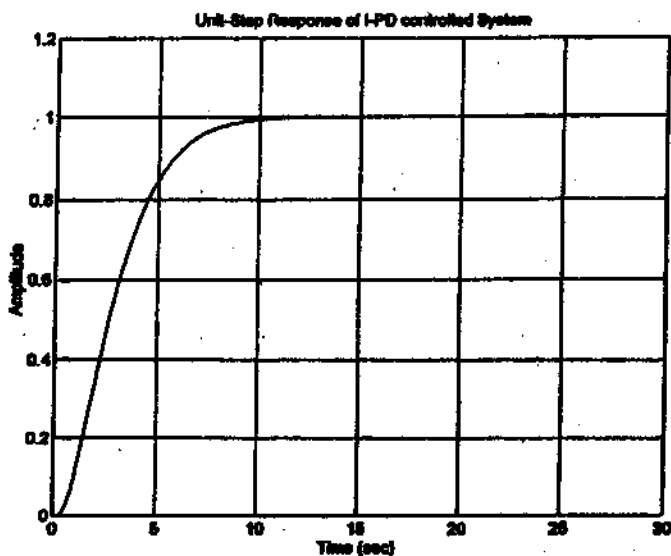

Notice that the response is slow but shows no overshoot. The closed-loop poles are shown in the following MATLAB output.

```
roots(den)  
ans =  
-2.3514 + 4.8215i  
-2.3514 - 4.8215i  
-0.6486 + 0.1568i  
-0.6486 - 0.1568i
```

Since the dominant closed-loop poles are located very close to the  $j\omega$  axis, the response speed is very slow compared with that of the closed-loop system shown in Figure 10-59 (a).

**B-10-5.** For the PID controlled system shown in Figure 10-59(a), the closed-loop transfer function between the output and the disturbance input is

$$\begin{aligned} \frac{C(s)}{D(s)} &= \frac{s}{s^2(s+1)(s+5) + 39.42(s + 0.3250 + 0.7692s^2)} \\ &= \frac{s}{s^4 + 6s^3 + 35.3219s^2 + 39.42s + 12.8112} \end{aligned}$$

For the I-PD controlled system shown in Figure 10-59(b), the closed-loop transfer function between the output and the disturbance input can be obtained as follows:

$$\begin{aligned} \frac{C(s)}{D(s)} &= \frac{s}{s^2(s+1)(s+5) + 39.42(s + 0.3250 + 0.7692s^2)} \\ &= \frac{s}{s^4 + 6s^3 + 35.3219s^2 + 39.42s + 12.8112} \end{aligned}$$

Since the two closed-loop transfer functions are identical, we get the same unit-step response curves for the two systems. The following MATLAB program produces the response to the unit-step disturbance input. The resulting response curve is shown below.

```

% ***** Unit-step response *****
num = [0 0 0 1 0];
den = [1 6 35.3219 39.42 12.8112];
step(num,den)
grid
title('Response to Unit-Step Disturbance Input')
    
```

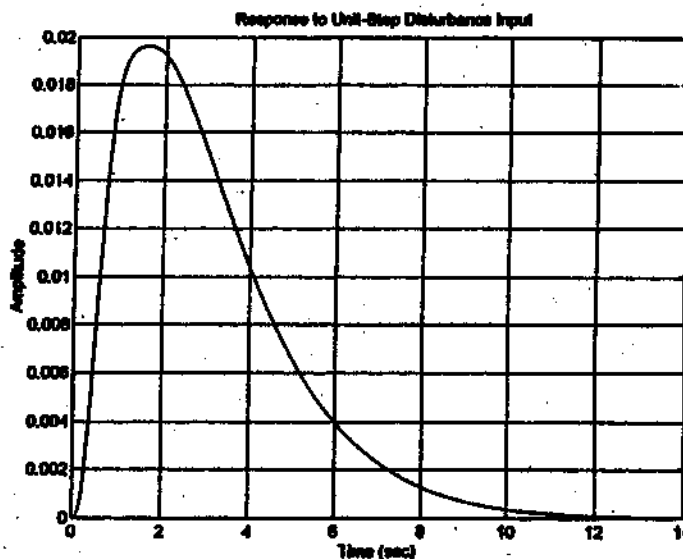

The closed-loop transfer function  $C(s)/R(s)$  of the system of Figure 10-59(a) is obtained as follows: [We assume that  $D(s) = 0$ .]

$$\begin{aligned} \frac{C(s)}{R(s)} &= \frac{39.42 \left(1 + \frac{1}{3.0775} + 0.7692s\right) \frac{1}{s(s+1)(s+5)}}{1 + 39.42 \left(1 + \frac{1}{3.0775} + 0.7692s\right) \frac{1}{s(s+1)(s+5)}} \\ &= \frac{30.3215s^2 + 39.42s + 12.8112}{s^4 + 6s^3 + 35.32186s^2 + 39.42s + 12.8112} \end{aligned}$$

The closed-loop transfer function  $C(s)/R(s)$  of the system of Figure 10-59(b) is obtained as follows: [We assume that  $D(s) = 0$ .]

$$\begin{aligned} \frac{C(s)}{R(s)} &= \frac{\frac{39.42}{s(s+1)(s+5) + 39.42(1+0.7692s)} \frac{1}{3.0775}}{1 + \frac{39.42}{s(s+1)(s+5) + 39.42(1+0.7692s)} \frac{1}{3.0775}} \\ &= \frac{12.8112}{s^4 + 6s^3 + 35.32186s^2 + 39.42s + 12.8112} \end{aligned}$$

Note that the characteristic equation (denominator) for both systems are the same, but the numerators are different.

**B-10-6.** For the reference input, the closed-loop transfer function is

$$\frac{C(s)}{R(s)} = \frac{G_1(s) G_2(s)}{1 + G_1(s) G_2(s) H(s)}$$

For the disturbance input,

$$\frac{C(s)}{D(s)} = \frac{G_2(s)}{1 + G_1(s) G_2(s) H(s)}$$

For the noise input,

$$\frac{C(s)}{N(s)} = - \frac{G_1(s) G_2(s) H(s)}{1 + G_1(s) G_2(s) H(s)}$$

Notice that the characteristic equations for the three closed-loop transfer functions are the same;

$$1 + G_1(s) G_2(s) H(s) = 0$$

That is, the characteristic equation for this system is the same regardless of which input signal is chosen as input.

**B-10-7.** The closed-loop transfer function  $C(s)/R(s)$  for the reference input is

$$\frac{C(s)}{R(s)} = \frac{\frac{G_1 G_2 G_3}{1 + G_2 G_3 H_2}}{1 + \frac{G_1 G_2 G_3 H_1}{1 + G_2 G_3 H_2}} = \frac{G_1 G_2 G_3}{1 + G_2 G_3 H_2 + G_1 G_2 G_3 H_1}$$

The closed-loop transfer function  $C(s)/D(s)$  for the disturbance input is obtained as follows: Noting that the feedforward transfer function is  $G_3(s)$  and the feedback transfer function is  $[-G_1(s)H_1(s) - H_2(s)]G_2(s)$ , and that the closed-loop system is a positive-feedback system, we have

$$\begin{aligned} \frac{C(s)}{D(s)} &= \frac{G_3}{1 - G_3 [-G_1 H_1 - H_2] G_2} \\ &= \frac{G_3}{1 + G_1 G_2 G_3 H_1 + G_2 G_3 H_2} \end{aligned}$$

**B-10-8.** For the system shown in Figure 10-62 (b), the closed-loop transfer function for the disturbance input is

$$\frac{C(s)}{D(s)} = \frac{-K G(s) H(s)}{1 + K G(s) H(s)}$$

To minimize the effect of disturbances, the adjustable gain  $K$  should be chosen as small as possible. Thus, the answer to the question is "no".

**B-10-9.**

(a)

$$\frac{Y(s)}{R(s)} = \frac{G_{c1} G_p}{1 + G_{c1} G_{c2} G_p}$$

$$\frac{Y(s)}{D(s)} = \frac{G_p}{1 + G_{c1} G_{c2} G_p}$$

$$\frac{Y(s)}{N(s)} = \frac{-G_{c1} G_{c2} G_p}{1 + G_{c1} G_{c2} G_p}$$

Hence

$$G_{yr} = G_{c1} G_{yd}$$

$$G_{yn} = \frac{G_{yd} - G_p}{G_p}$$

If  $G_{yd}$  is given, then  $G_{yn}$  is fixed but  $G_{yr}$  is not fixed because  $G_{c1}$  is independent of  $G_{yd}$ . Thus, two closed-loop transfer functions among three closed-loop transfer functions  $G_{yr}$ ,  $G_{yd}$ , and  $G_{yn}$  are independent. Hence, the system is a two-degrees-of-freedom system.

(b)

$$\frac{Y(s)}{R(s)} = \frac{G_{c1} G_{c2} G_p}{1 + G_{c2} G_p}$$

$$\frac{Y(s)}{D(s)} = \frac{G_p}{1 + G_{c2} G_p}$$

$$\frac{Y(s)}{N(s)} = \frac{-G_{c2} G_p}{1 + G_{c2} G_p}$$

Hence

$$G_{yr} = G_{c1} G_{c2} G_{yd}$$

$$G_{yn} = \frac{G_{yd} - G_p}{G_p}$$

If  $G_{yd}$  is given, then  $G_{yn}$  is fixed but  $G_{yr}$  is not fixed because  $G_{c1}G_{c2}$  is independent of  $G_{yd}$ . Thus, two closed-loop transfer functions among three closed-loop transfer functions  $G_{yr}$ ,  $G_{yd}$ , and  $G_{yn}$  are independent. Hence, the system is a two-degrees-of-freedom system.

(c)

$$\frac{Y(s)}{R(s)} = \frac{G_{c1} G_p}{1 + G_{c2} G_p}$$

$$\frac{Y(s)}{D(s)} = \frac{G_p}{1 + G_{c2} G_p}$$

$$\frac{Y(s)}{N(s)} = \frac{-G_{c2} G_p}{1 + G_{c2} G_p}$$

Hence

$$G_{yr} = G_{c1} G_{yd}$$

$$G_{yn} = \frac{G_{yd} - G_p}{G_p}$$

If  $G_{yd}$  is given, then  $G_{yn}$  is fixed.  $G_{yr}$  is not fixed because  $G_{c1}$  is independent of  $G_{yd}$ . Thus, the system is a two-degrees-of-freedom system.

**B-10-10.** Define the input signal to box  $G_{c3}$  as  $A(s)$ . Then, for  $D(s) = 0$  and  $N(s) = 0$ , we have

$$A(s) = G_{c2} R(s) + G_{c1} [R(s) - Y(s)] - G_1 G_{c3} A(s)$$

$$Y(s) = G_{c3} G_1 G_2 A(s)$$

Eliminating  $A(s)$  from the above two equations, we get

$$Y(s) = G_{c3} G_1 G_2 \frac{(G_{c1} + G_{c2}) R(s) - G_{c1} Y(s)}{1 + G_{c3} G_1}$$

or

$$(1 + G_{c3} G_1 + G_{c1} G_{c3} G_1 G_2) Y(s) = G_{c3} G_1 G_2 (G_{c1} + G_{c2}) R(s)$$

Hence,

$$\frac{Y(s)}{R(s)} = \frac{(G_{c1} + G_{c2}) G_{c3} G_1 G_2}{1 + G_{c3} G_1 + G_{c1} G_{c3} G_1 G_2} \quad (1)$$

To find  $Y(s)/D(s)$ , we may proceed as follows. For  $R(s) = 0$  and  $N(s) = 0$ , we have

$$A(s) = G_{c1} [-Y(s)] - G_1 [D(s) + G_{c3} A(s)]$$

$$Y(s) = G_1 G_2 [D(s) + G_{c3} A(s)]$$

Hence

$$Y(s) = G_1 G_2 \left[ D(s) + G_{c3} \frac{-G_{c1} Y(s) - G_1 D(s)}{1 + G_{c3} G_1} \right]$$

Simplifying, we have

$$(1 + G_{c3} G_1 + G_{c1} G_{c3} G_1 G_2) Y(s) = G_1 G_2 D(s)$$

or

$$\frac{Y(s)}{D(s)} = \frac{G_1 G_2}{1 + G_{c3} G_1 + G_{c1} G_{c3} G_1 G_2} \quad (2)$$

Next, we shall find  $Y(s)/N(s)$ . For  $R(s) = 0$  and  $D(s) = 0$ , we have

$$A(s) = -G_{c1} [Y(s) + N(s)] - G_{c3} G_1 A(s)$$

$$Y(s) = G_{c3} G_1 G_2 A(s)$$

Therefore,

$$Y(s) = G_{c3} G_1 G_2 \frac{-G_{c1} Y(s) - G_{c1} N(s)}{1 + G_{c3} G_1}$$

or

$$(1 + G_{c3} G_1 + G_{c1} G_{c3} G_1 G_2) Y(s) = -G_{c1} G_{c3} G_1 G_2 N(s)$$

Hence,

$$\frac{Y(s)}{N(s)} = \frac{-G_{c1} G_{c3} G_1 G_2}{1 + G_{c3} G_1 + G_{c1} G_{c3} G_1 G_2} \quad (3)$$

From Equations (1), (2), and (3), we get

$$G_{yn} = -G_{c1} G_{c3} G_{yd}$$

$$G_{yr} = -G_{yn} + G_{c2} G_{c3} G_{yd}$$

If  $G_{yd}$  is given,  $G_{yn}$  is independent of  $G_{yd}$  because  $G_{c1}G_{c3}$  is independent of  $G_{yd}$ .  $G_{yr}$  is independent of  $G_{yd}$  and  $G_{yn}$  because  $G_{c2}G_{c3}$  is independent of  $G_{yn}$  and  $G_{yd}$ . Hence, all three closed-loop transfer functions  $G_{yr}$ ,  $G_{yd}$ , and  $G_{yn}$  are independent. Hence, the system is a three-degrees-of-freedom system.

---

**B-10-11.** The open-loop transfer function of the system is

$$\begin{aligned} G(s) &= \frac{K(s+a)^2}{s} \frac{1.2}{(0.3s+1)(s+1)(1.2s+1)} \\ &= \frac{1.2Ks^2 + 2.4KAs + 1.2Ka^2}{0.36s^4 + 1.86s^3 + 2.5s^2 + s} \end{aligned}$$

Hence, the closed-loop transfer function is

$$\frac{C(s)}{R(s)} = \frac{1.2Ks^2 + 2.4KAs + 1.2Ka^2}{0.36s^4 + 1.86s^3 + (2.5 + 1.2K)s^2 + (1 + 2.4KA)s + 1.2Ka^2}$$

The requirement in this problem is that the maximum overshoot in the unit-step response is that

$$M_p < 0.1, \quad M_p > 0.02$$

where  $M_p$  is the maximum overshoot. In terms of the output  $y$  to the unit-step input,

$$m < 1.1, \quad m > 1.02$$

where

$$m = \max(y)$$

A possible MATLAB program to obtain a set of the values of  $K$  and  $a$  that satisfies the requirement is given on the next page. The resulting unit-step response curve is shown also on the next page.

```

% ***** Search of K and a Values for 0.02 < Mp < 0.10 *****

t = 0:0.01:8;
for K = 4:-0.05:1;
    for a = 4:-0.05:0.4;
        num = [0 0 1.2*K 2.4*K*a 1.2*K*a^2];
        den = [0.36 1.86 2.5+1.2*K 1+2.4*K*a 1.2*K*a^2];
        y = step(num,den,t);
        m = max(y);
        if m < 1.1 & m > 1.02
            break;
        end
    end
end
if m < 1.1 & m > 1.02
    break;
end
end
end
plot(t,y)
grid
title('Unit-Step Response')
xlabel('t Sec')
ylabel('Output')
KK = num2str(K);
aa = num2str(a);
text(5.1,0.54,'K ='), text(5.6,0.54, KK)
text(5.1,0.46,'a ='), text(5.6,0.46, aa)
sol = [K a m]

sol =

    4.0000    0.7000    1.0846

```

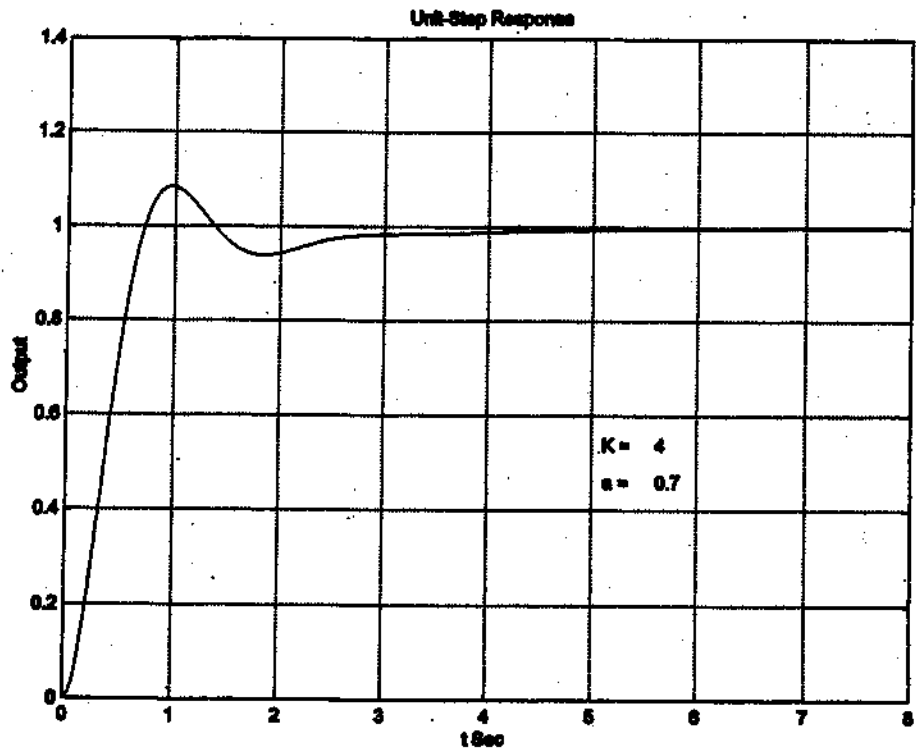

The selected set of K and a is

$$K = 4, \quad a = 0.7$$

The maximum overshoot is 8.46 %.

**B-10-12.** The feedforward transfer function is

$$G(s) = \frac{1.2K(s+a)^2}{s(0.3s+1)(s+1)(1.2s+1)}$$

The closed-loop transfer function is

$$\frac{C(s)}{R(s)} = \frac{1.2Ks^2 + 2.4Ka s + 1.2Ka^2}{0.36s^4 + 1.86s^3 + (2.5 + 1.2K)s^2 + (1 + 2.4Ka)s + 1.2Ka^2}$$

The requirements in this problem are

$$1.03 < m < 1.08, \quad t_s < 2 \text{ sec}$$

where m = maximum output. The search region is

$$2 \leq K \leq 4, \quad 0.5 \leq a \leq 3$$

The step size is 0.05 for both K and a. A MATLAB program to obtain the first set of K and a that satisfies the requirements is shown below.

```
% ***** Search of K and a Values for 0.03 < Mp < 0.08 and ts < 2 sec *****
t = 0:0.01:8;
for K = 4:-0.05:2;
    for a = 3:-0.05:0.5;
        num = [0 0 1.2*K 2.4*K*a 1.2*K*a^2];
        den = [0.36 1.86 2.5+1.2*K 1+2.4*K*a 1.2*K*a^2];
        y = step(num,den,t);
        m = max(y);
        s = 801; while y(s) > 0.98 & y(s) < 1.02;
            s = s-1; end;
        ts = (s-1)*0.01;
        if m < 1.08 & m > 1.03 & ts < 2.0
            break;
        end
    end
end
if m < 1.08 & m > 1.03 & ts < 2.0
    break
end
end
plot(t,y)
grid
title('Unit-Step Response')
xlabel('t sec')
ylabel('Output')
solution = [K a m ts]

solution =

2.6000 0.8500 1.0774 1.8400
```

The first set of  $K$  and  $a$  that satisfies the requirements is  $K = 2.6$  and  $a = 0.85$ . The maximum overshoot  $M_p$  and settling time  $t_s$  are 7.74 % and 1.84 sec, respectively. The response curve with  $K = 2.6$  and  $a = 0.85$  is shown below.

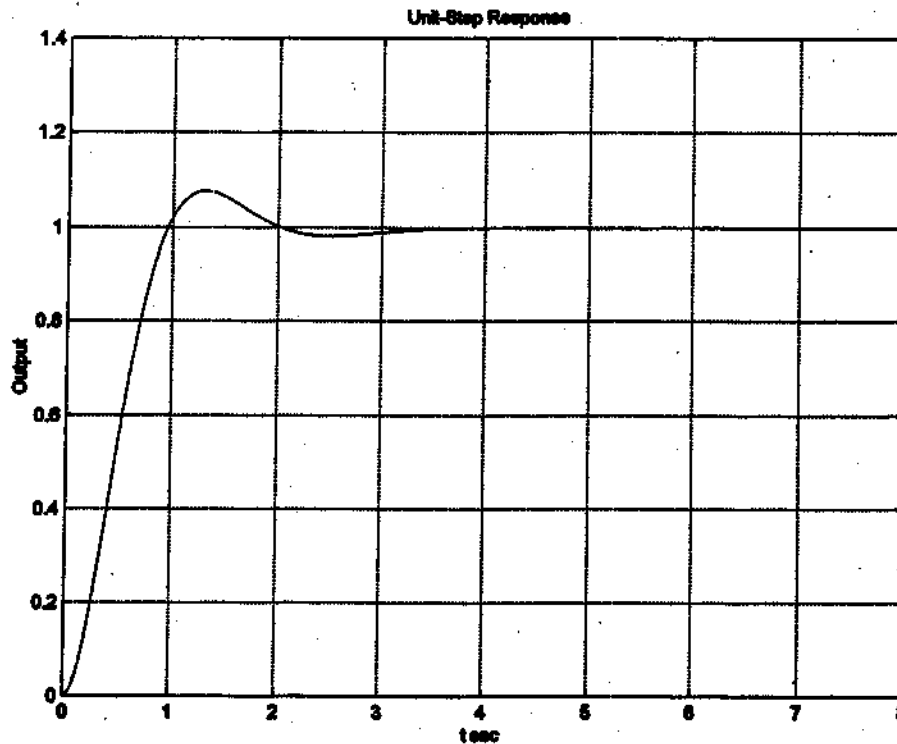

Next, we shall obtain all possible sets of  $K$  and  $a$  that satisfy the requirements. The following MATLAB program produces the desired result.

```
% ***** Search of all possible Sets of K and a Values for 0.03 < Mp < 0.08
% and ts < 2 sec *****

t = 0:0.01:8;
k = 0;
for i = 1:41;
    K(i) = 4.05 - i*0.05;
    for j = 1:51;
        a(j) = 3.05 - j*0.05;
        num = [0 0 1.2*K(i) 2.4*K(i)*a(j) 1.2*K(i)*a(j)*a(j)];
        den = [0.36 1.86 2.5+1.2*K(i) 1+2.4*K(i)*a(j) 1.2*K(i)*a(j)*a(j)];
        y = step(num,den,t);
        m = max(y);
        s = 801; while y(s) > 0.98 & y(s) < 1.02;
            s = s-1; end;
        ts = (s-1)*0.01;
        if m < 1.08 & m > 1.03 & ts < 2.0
            k = k+1;
            table(k,:) = [K(i) a(j) m ts];
        end
    end
end
end
table(k,:) = [K(i) a(j) m ts]
```

```
table =
```

2.6000	0.8500	1.0774	1.8400
2.5500	0.8500	1.0737	1.8500
2.5000	0.8500	1.0700	1.8600
2.4500	0.8500	1.0662	1.8800
2.4000	0.8500	1.0624	1.8900
2.3500	0.8500	1.0585	1.9000
2.3000	0.8500	1.0546	1.9100
2.2500	0.8500	1.0507	1.9200
2.2000	0.8500	1.0468	1.9300
2.1500	0.8500	1.0428	1.9400
2.1000	0.8500	1.0388	1.9400
2.0500	0.8500	1.0348	1.9400
2.0000	0.5000	0.9552	8.0000

```
sorttable = sortrows(table,3)
```

```
sorttable =
```

2.0000	0.5000	0.9552	8.0000
2.0500	0.8500	1.0348	1.9400
2.1000	0.8500	1.0388	1.9400
2.1500	0.8500	1.0428	1.9400
2.2000	0.8500	1.0468	1.9300
2.2500	0.8500	1.0507	1.9200
2.3000	0.8500	1.0546	1.9100
2.3500	0.8500	1.0585	1.9000
2.4000	0.8500	1.0624	1.8900
2.4500	0.8500	1.0662	1.8800
2.5000	0.8500	1.0700	1.8600
2.5500	0.8500	1.0737	1.8500
2.6000	0.8500	1.0774	1.8400

```
K = sorttable(13,1)
```

```
K =
```

```
2.6000
```

```
a = sorttable(13,2)
```

```
a =
```

```
0.8500
```

```
num = [0 0 1.2*K 2.4*K*a 1.2*K*a^2];  
den = [0.36 1.86 2.5+1.2*K 1+2.4*K*a 1.2*K*a^2];  
y = step(num,den,t);  
plot(t,y)  
grid  
hold  
Current plot held
```

```

K = sortable(2,1)

K =

    2.0500

a = sortable(2,2)

a =

    0.8500

num = [0 0 1.2*K 2.4*K*a 1.2*K*a^2];
den = [0.36 1.86 2.5+1.2*K 1+2.4*K*a 1.2*K*a^2];
y = step(num,den,t);
plot(t,y)
title('Unit-Step Response Curves')
xlabel('t sec')
ylabel('Outputs')
text(2.2,1.1,'K = 2.6, a = 0.85')
text(2.2,0.9,'K = 2.05, a = 0.85')

```

There are 12 sets of the values of  $K$  and  $a$  that satisfy the requirements. All sets produces similar response curves. The best choice of the set depends on the system objective. If a small maximum overshoot is desired, then  $K = 2.05$  and  $a = 0.85$  will be the best choice. If the shorter settling time is more important than a small maximum overshoot, then  $K = 2.6$  and  $a = 0.85$  will be the best choice. The unit-step response curves for the two cases are shown below.

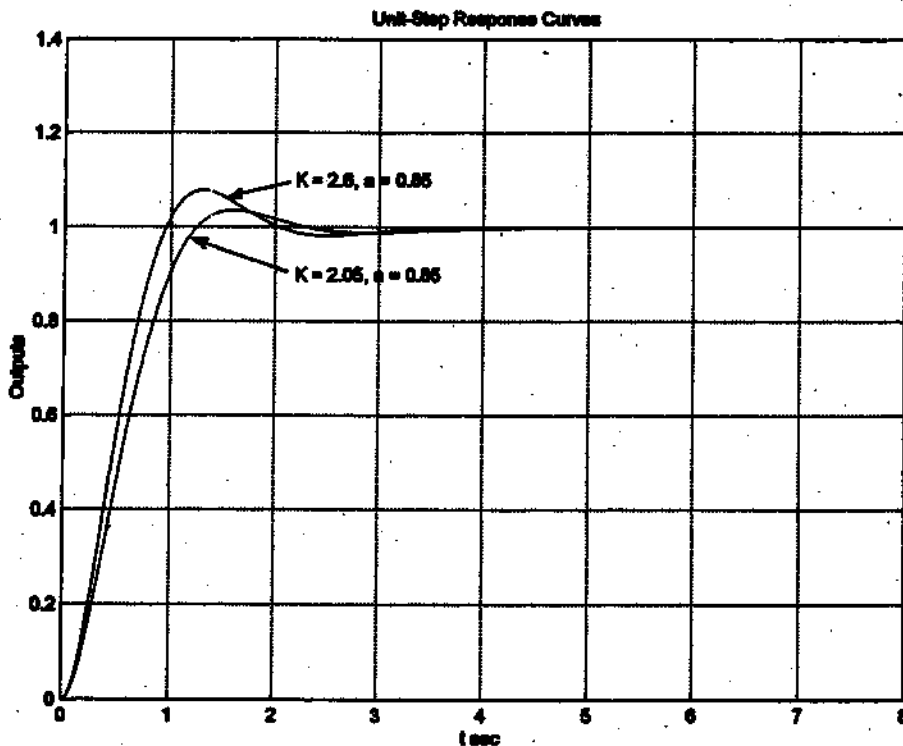

**B-10-13.**

$$G_p(s) = \frac{3(s+5)}{s(s+1)(s^2+4s+13)}$$

The closed-loop transfer functions  $Y(s)/D(s)$  and  $Y(s)/R(s)$  are given by

$$\frac{Y(s)}{D(s)} = \frac{G_p(s)}{1+G_{c1}(s)G_p(s)} = \frac{G_p}{1+G_{c1}G_p}$$

and

$$\frac{Y(s)}{R(s)} = \frac{[G_{c1}(s)+G_{c2}(s)]G_p(s)}{1+G_{c1}(s)G_p(s)} = \frac{(G_{c1}+G_{c2})G_p}{1+G_{c1}G_p}$$

Assume that  $G_{c1}(s)$  is a PID controller with a filter and has the following form:

$$G_{c1}(s) = \frac{K(s+a)^2}{s} \frac{s^2+4s+13}{(s+5)(s+27)}$$

The characteristic equation for the system is

$$\begin{aligned} 1+G_{c1}G_p &= 1 + \frac{K(s+a)^2}{s} \frac{s^2+4s+13}{(s+5)(s+27)} \frac{3(s+5)}{s(s+1)(s^2+4s+13)} \\ &= 1 + \frac{3K(s+a)^2}{s^2(s+1)(s+27)} \end{aligned}$$

With a trial-and-error search of  $K$  and  $a$  with MATLAB, we find a possible set of  $K$  and  $a$  as follows:

$$K = 58, \quad a = 1.4$$

With this chosen set of  $K$  and  $a$ , the controller  $G_{c1}(s)$  becomes as follows:

$$\begin{aligned} G_{c1}(s) &= \frac{58(s+1.4)^2}{s} \frac{s^2+4s+13}{(s+5)(s+27)} \\ &= \frac{58s^2+162.4s+113.68}{s} \frac{s^2+4s+13}{(s+5)(s+27)} \end{aligned}$$

The closed-loop transfer function  $Y(s)/D(s)$  is obtained as

$$\begin{aligned} \frac{Y(s)}{D(s)} &= \frac{\frac{3(s+5)}{s(s+1)(s^2+4s+13)}}{1 + \frac{3 \times 58 (s+1.4)^2}{s^2(s+1)(s+27)}} \\ &= \frac{3s^3 + 96s^2 + 405s}{(s^2+4s+13)(s^4+28s^3+201s^2+487.2s+341.04)} \end{aligned}$$

The response curve when  $D(s)$  is a unit-step disturbance is shown in the next page.

Next, we consider the response to reference inputs. The closed-loop transfer function  $Y(s)/R(s)$  is

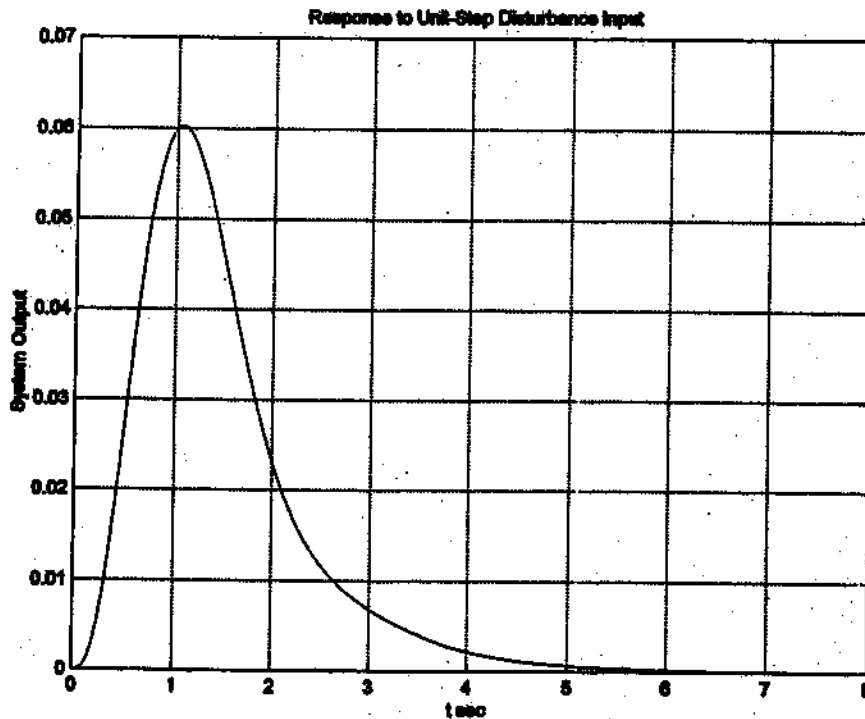

$$\frac{Y(s)}{R(s)} = \frac{(G_{c1} + G_{c2})G_p}{1 + G_{c1}G_p} = (G_{c1} + G_{c2}) \frac{Y(s)}{D(s)}$$

Define  $G_{c1}(s) + G_{c2}(s) = G_c(s)$ . Then

$$\begin{aligned} \frac{Y(s)}{R(s)} &= G_c \frac{Y(s)}{D(s)} = G_c \frac{G_p}{1 + G_{c1}G_p} \\ &= G_c \frac{3s^3 + 96s^2 + 405s}{s^2 + 4s + 13} \\ &= \frac{3s^3 + 96s^2 + 405s}{s^4 + 28s^3 + 201s^2 + 487.2s + 341.04} \end{aligned}$$

To satisfy the requirements on the responses to the ramp reference input and acceleration reference input, we use the zero-placement approach. That is, we choose the numerator of  $Y(s)/R(s)$  to be the sum of the last three terms of the denominator, or

$$G_c \frac{3s^3 + 96s^2 + 405s}{s^2 + 4s + 13} = 201s^2 + 487.2s + 341.04$$

from which we get

$$\begin{aligned} G_c(s) &= \frac{(201s^2 + 487.2s + 341.04)(s^2 + 4s + 13)}{3(s^3 + 32s^2 + 135s)} \\ &= \frac{67s^2 + 162.4s + 113.68}{s} \frac{s^2 + 4s + 13}{(s+5)(s+27)} \end{aligned}$$

The closed-loop transfer function  $Y(s)/R(s)$  now becomes

$$\frac{Y(s)}{R(s)} = \frac{201s^2 + 487.2s + 341.04}{s^4 + 28s^3 + 201s^2 + 487.2s + 341.04}$$

The response curves to the unit-step reference input, unit-ramp reference input, and unit-acceleration reference input are shown below and on the next page.

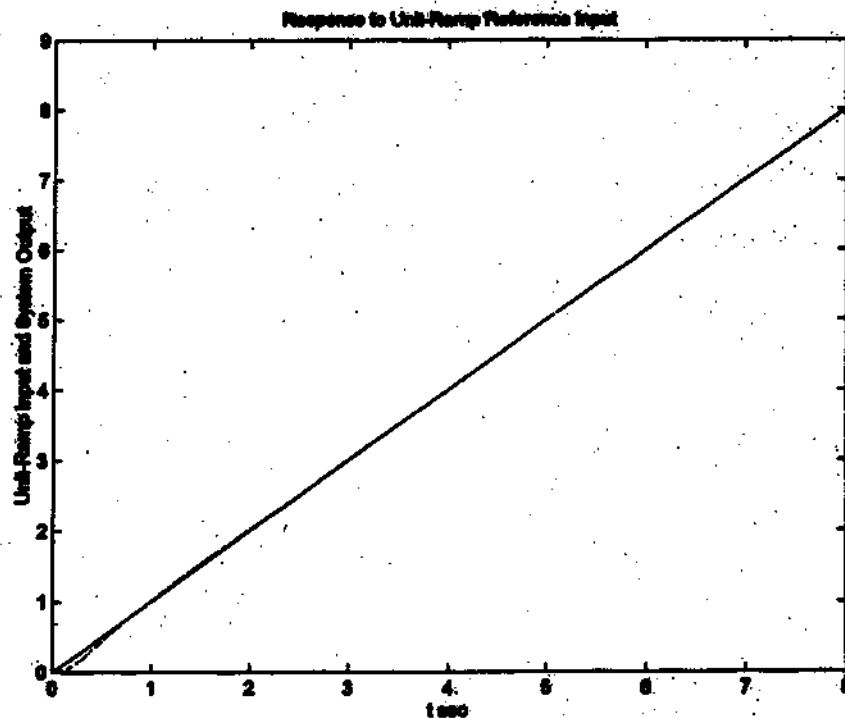
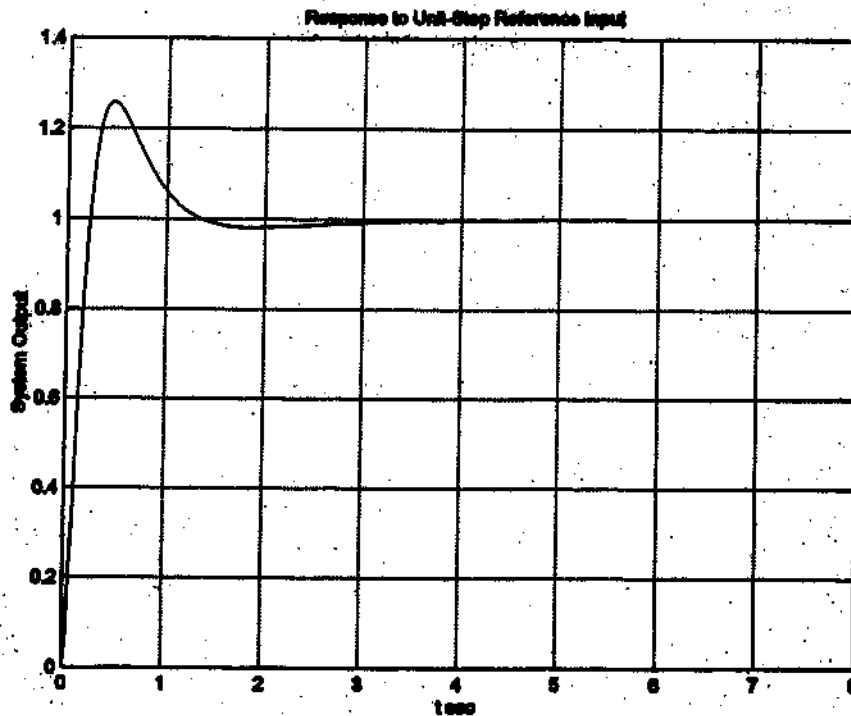

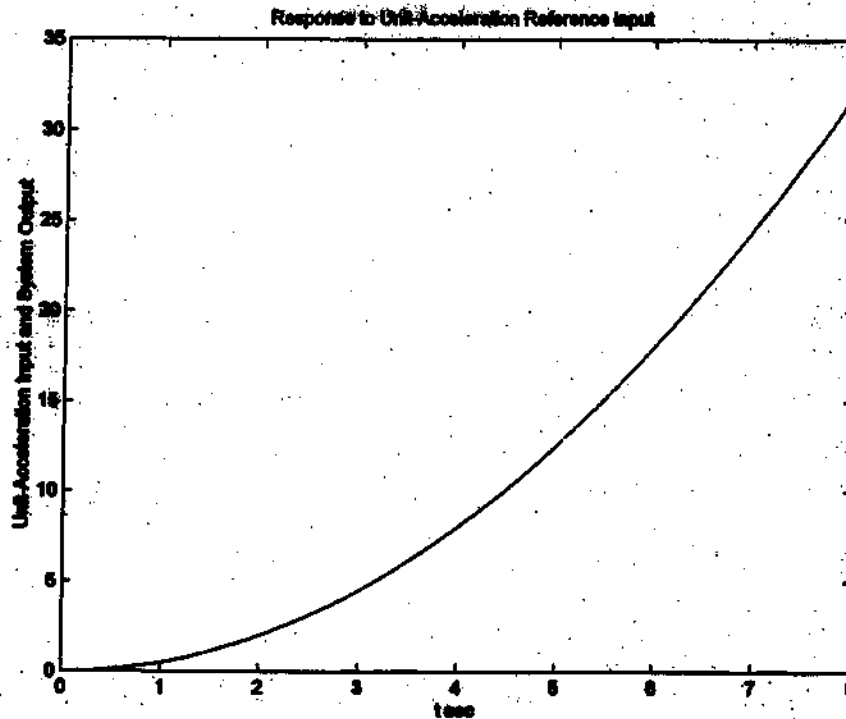

Notice that the maximum overshoot in the unit-step response is approximately 25 % and the settling time is approximately 1.25 sec. The steady-state errors in the ramp response and acceleration response are zero. Therefore, the designed controller  $G_C(s)$  is satisfactory.

Finally, we determine  $G_{C2}(s)$ . Noting that

$$G_{C2}(s) = G_C(s) - G_{C1}(s)$$

where

$$G_C(s) = \frac{67s^2 + 162.4s + 113.68}{s} \cdot \frac{s^2 + 4s + 13}{(s+5)(s+27)}$$

and

$$G_{C1}(s) = \frac{58s^2 + 162.4s + 113.68}{s} \cdot \frac{s^2 + 4s + 13}{(s+5)(s+27)}$$

we have

$$G_{C2}(s) = 9s \cdot \frac{s^2 + 4s + 13}{(s+5)(s+27)}$$

The block diagram of the designed system is shown on the next page. Note that

$$\frac{s^2 + 4s + 13}{(s+5)(s+27)}$$

is a filter and is a part of the controller.

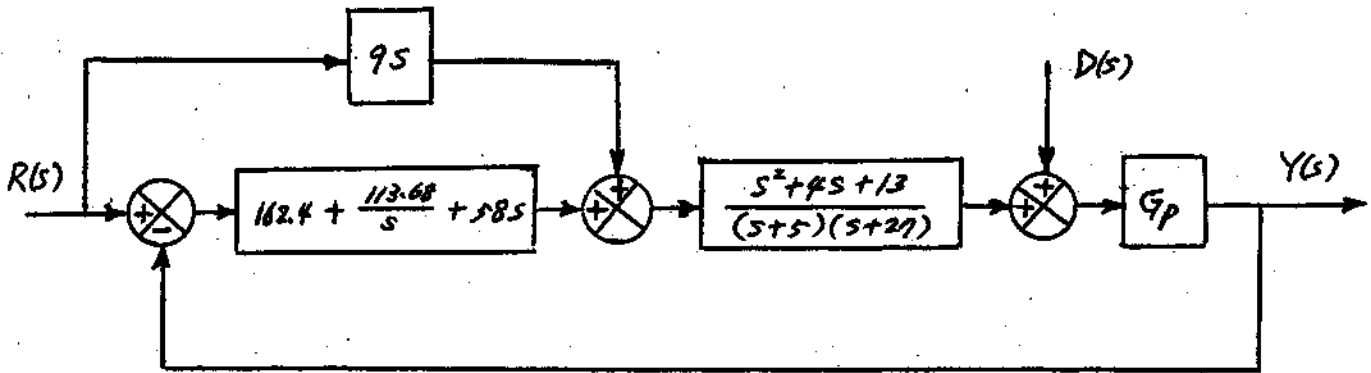

B-10-14.

$$G_p(s) = \frac{2(s+1)}{s(s+3)(s+5)}$$

The closed-loop transfer functions  $Y(s)/D(s)$  and  $Y(s)/R(s)$  are given by

$$\frac{Y(s)}{D(s)} = \frac{G_p(s)}{1 + G_p(s) [G_{c1}(s) + G_{c2}(s)]} = \frac{G_p}{1 + (G_{c1} + G_{c2}) G_p}$$

and

$$\frac{Y(s)}{R(s)} = \frac{G_{c1}(s) G_p(s)}{1 + G_p(s) [G_{c1}(s) + G_{c2}(s)]} = \frac{G_{c1} G_p}{1 + (G_{c1} + G_{c2}) G_p}$$

Let us define  $G_{c1} + G_{c2} = G_c$ . Then

$$\frac{Y(s)}{D(s)} = \frac{G_p}{1 + G_c G_p}$$

Let us assume that  $G_c(s)$  is a PID controller and has the following form:

$$G_c(s) = \frac{K(s+a)^2}{s}$$

The characteristic equation for the system is

$$1 + G_c G_p = 1 + \frac{K(s+a)^2}{s} \frac{2(s+1)}{s(s+3)(s+5)}$$

In what follows, we shall use the root-locus approach to determine the values of  $K$  and  $a$ . After trial-and-error analysis with MATLAB, we choose the dominant closed-loop poles to be at  $s = -4 \pm j0.2$ .

The angle deficiency at the desired closed-loop pole at  $s = -4 + j0.2$  is obtained as follows:

$$\begin{aligned} & -177.1376^\circ - 177.1376^\circ - 168.6901^\circ - 11.3099^\circ + 176.1859^\circ + 180^\circ \\ & = -178.0893^\circ \end{aligned}$$

(Note that the poles are at  $s = 0$ ,  $s = 0$ ,  $s = -3$ ,  $s = -5$  and the zero is at  $s = -1$ .) The double zero at  $s = -a$  must contribute  $178.0893^\circ$ . (Each zero must contribute  $89.04465^\circ$ .) By a simple calculation, we find

$$a = 4.0033$$

The controller  $G_c(s)$  is then determined as

$$G_c(s) = \frac{K(s+4.0033)^2}{s}$$

The constant  $K$  must be determined by use of the magnitude condition. This condition is

$$\left| G_c(s) G_p(s) \right|_{s=-4+j0.2} = 1$$

Since

$$\left| \frac{K(s+4.0033)^2}{s} \frac{2(s+1)}{s(s+3)(s+5)} \right|_{s=-4+j0.2} = 1$$

we obtain

$$K = \left| \frac{s^2(s+3)(s+5)}{(s+4.0033)^2 2(s+1)} \right|_{s=-4+j0.2} = 69.3333$$

Hence

$$G_c(s) = \frac{69.3333 (s+4.0033)^2}{s}$$

Then the closed-loop transfer function  $Y(s)/D(s)$  can be obtained as

$$\begin{aligned} \frac{Y(s)}{D(s)} &= \frac{G_p}{1 + G_c G_p} = \frac{\frac{2(s+1)}{s(s+3)(s+5)}}{1 + \frac{69.3333 (s+4.0033)^2}{s} \frac{2(s+1)}{s(s+3)(s+5)}} \\ &= \frac{2s^2 + 2s}{s^4 + 146.6666 s^3 + 1263.9146 s^2 + 3332.5759 s + 2222.3279} \end{aligned}$$

The response curve when  $D(s)$  is a unit-step disturbance is shown below.

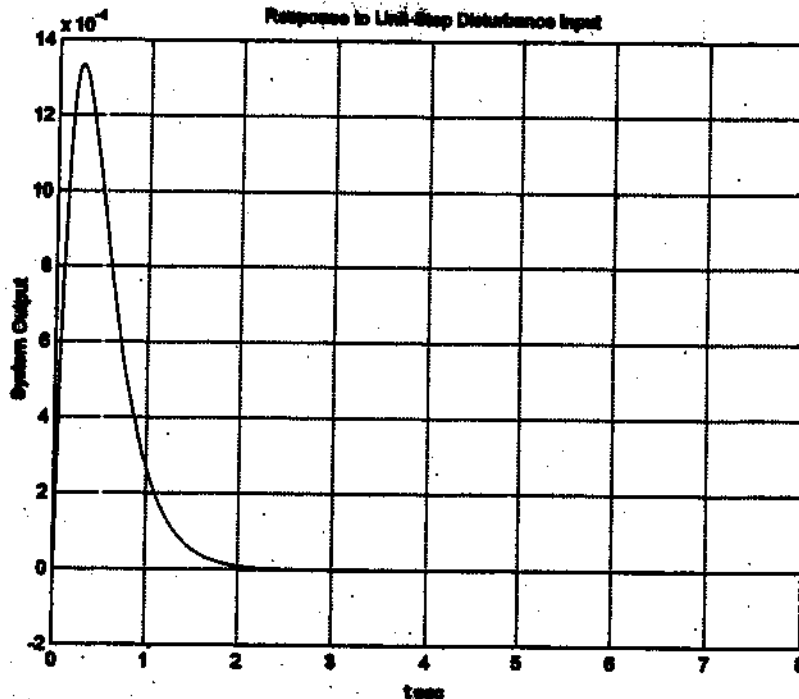

Next, we consider the responses to reference inputs. The closed-loop transfer function  $Y(s)/R(s)$  is

$$\frac{Y(s)}{R(s)} = \frac{G_{c1} G_p}{1 + (G_{c1} + G_{c2}) G_p} = G_{c1} \frac{Y(s)}{D(s)}$$

$$= \frac{(2s^2 + 2s) G_{c1}}{s^4 + 146.6666s^3 + 1263.9146s^2 + 3332.5759s + 2222.3279}$$

To satisfy the requirements on the responses to the ramp reference input and acceleration reference input, we use the zero-placement approach. That is, we choose the numerator of  $Y(s)/R(s)$  to be the sum of the last three terms of the denominator, or

$$(2s^2 + 2s) G_{c1} = 1263.9146s^2 + 3332.5759s + 2222.3279$$

from which we get

$$G_{c1} = \frac{631.9573s^2 + 1666.2880s + 1111.1640}{s(s+1)}$$

Hence, the closed-loop transfer function  $Y(s)/R(s)$  becomes as

$$\frac{Y(s)}{R(s)} = \frac{1263.9146s^2 + 3332.5759s + 2222.3279}{s^4 + 146.6666s^3 + 1263.9146s^2 + 3332.5759s + 2222.3279}$$

The response curves to the unit-step reference input, unit-ramp reference input, and unit-acceleration reference input are shown below and on the next page.

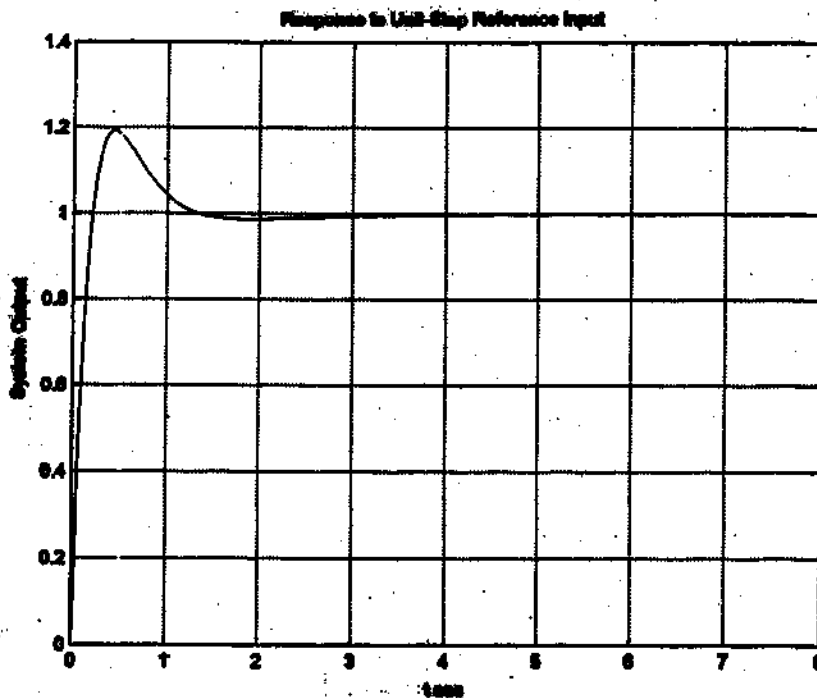

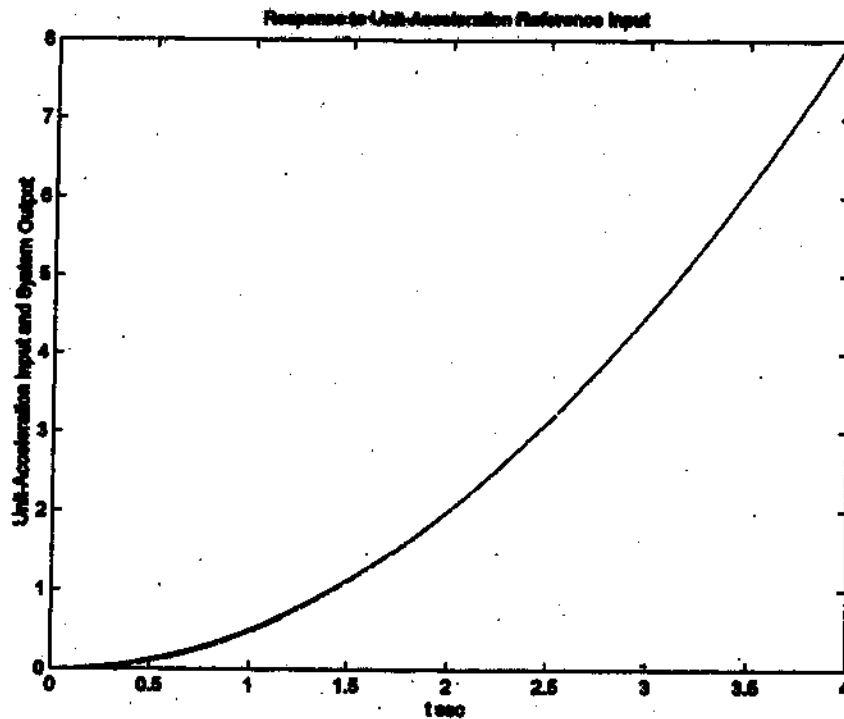
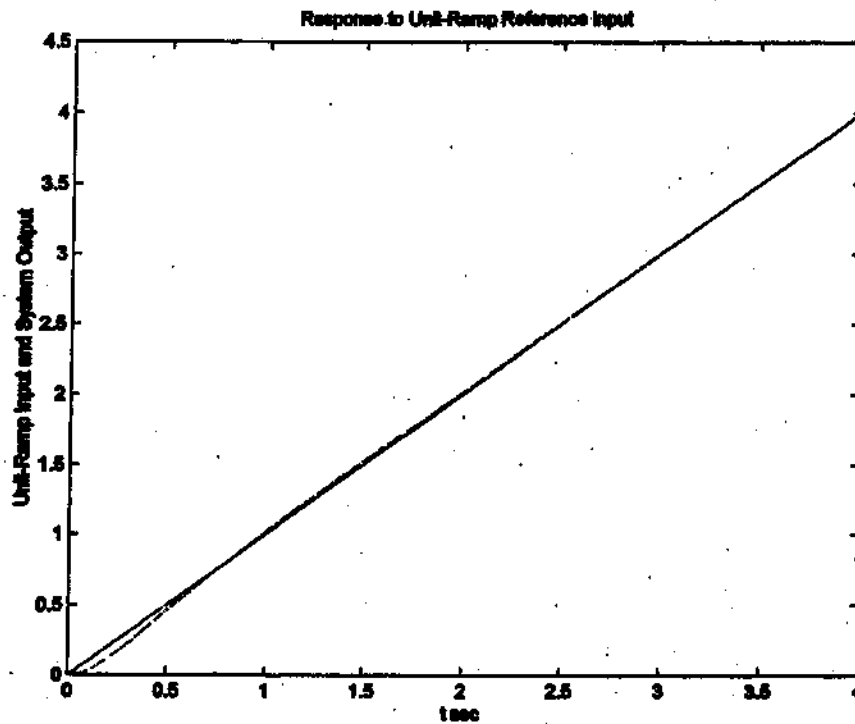

The maximum overshoot in the unit-step response is approximately 19 % and the settling time is approximately 1.3 sec (2% criterion) or 1.0 sec (5% criterion). The steady-state errors in the ramp response and acceleration response are zero. Therefore, the designed controller  $G_c(s)$  is satisfactory.

Finally, we determine  $G_{C2}(s)$ . Noting that

$$G_{C2}(s) = G_C(s) - G_{C1}(s)$$

where

$$G_C(s) = \frac{69.3333 (s+4.0033)^2}{s}$$

and

$$G_{C1}(s) = \frac{631.9573 s^2 + 1666.2880 s + 1111.1640}{s(s+1)}$$

we have

$$G_{C2}(s) = \frac{69.3333 s^2 - 7.5 s}{s+1}$$

A block diagram of the designed system is shown below.

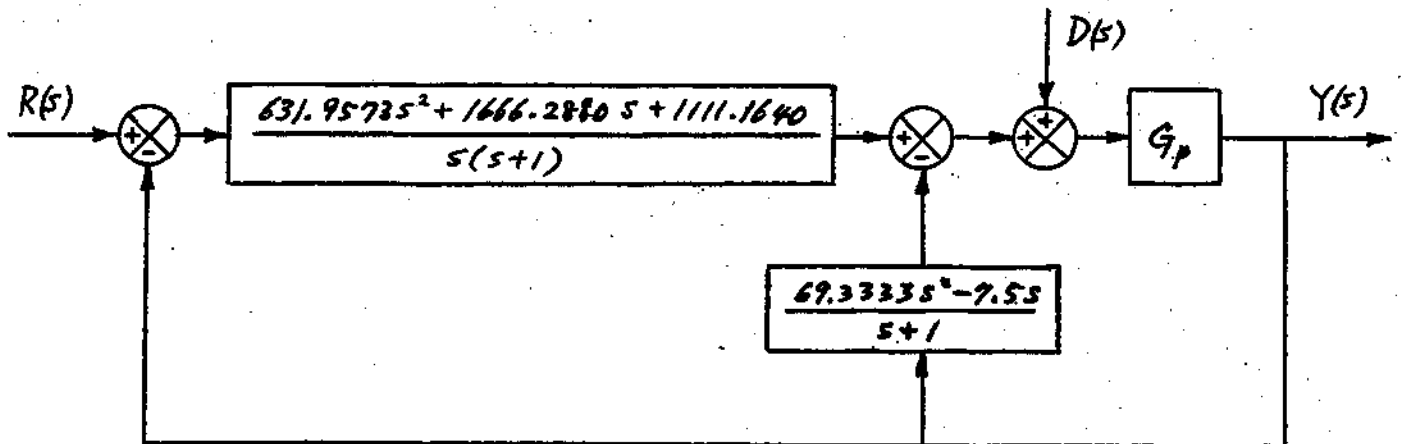

**B-10-15.**

$$G_p(s) = \frac{1}{s^2}$$

The closed-loop transfer functions  $Y(s)/D(s)$  and  $Y(s)/R(s)$  are given by

$$\frac{Y(s)}{D(s)} = \frac{G_p}{1 + (G_{C1} + G_{C2}) G_p}$$

and

$$\frac{Y(s)}{R(s)} = \frac{G_{C1} G_p}{1 + (G_{C1} + G_{C2}) G_p}$$

Let us define  $G_{C1} + G_{C2} = G_C$ . Then

$$\frac{Y(s)}{D(s)} = \frac{G_p}{1 + G_C G_p}$$

Assume that  $G_c$  is a PID controller and has the following form:

$$G_c(s) = \frac{K(s+a)^2}{s}$$

The characteristic equation for the system is

$$1 + G_c G_p = 1 + \frac{K(s+a)^2}{s} \frac{1}{s^2}$$

In what follows, we shall use the root-locus approach to determine the values of  $K$  and  $a$ . Let us choose the dominant closed-loop poles at

$$s = -7 \pm j1$$

Then, the angle deficiency at the desired closed-loop pole at  $s = -7 + j1$  is obtained as follows:

$$-171.8699^\circ \times 3 + 180^\circ = -335.6097^\circ$$

The double zero at  $s = -a$  must contribute  $335.6097^\circ$ . (Each zero must contribute  $167.80485^\circ$ .) By a simple calculation, we find  $a = 2.3729$ . The controller  $G_c(s)$  is then determined as

$$G_c(s) = \frac{K(s+2.3729)^2}{s}$$

where  $K$  is determined as

$$K = \left| \frac{s^3}{(s+2.3729)^2} \right|_{s=-7+j1} = 15.7767$$

Hence

$$G_c(s) = \frac{15.7767(s+2.3729)^2}{s}$$

Then the closed-loop transfer function  $Y(s)/D(s)$  can be obtained as

$$\begin{aligned} \frac{Y(s)}{D(s)} &= \frac{G_p}{1 + G_c G_p} = \frac{\frac{1}{s^2}}{1 + \frac{15.7767(s+2.3729)^2}{s} \frac{1}{s^2}} \\ &= \frac{1}{s^3 + 15.7767s^2 + 74.8731s + 88.8331} \end{aligned}$$

The response curve when  $D(s)$  is a unit-step disturbance is shown in the next page.

Next, we consider the response to reference inputs. The closed-loop transfer function  $Y(s)/R(s)$  is

$$\begin{aligned} \frac{Y(s)}{R(s)} &= \frac{G_{c1} G_p}{1 + (G_{c1} + G_{c2}) G_p} = G_{c1} \frac{Y(s)}{D(s)} \\ &= \frac{s G_{c1}}{s^3 + 15.7767s^2 + 74.8731s + 88.8331} \end{aligned}$$

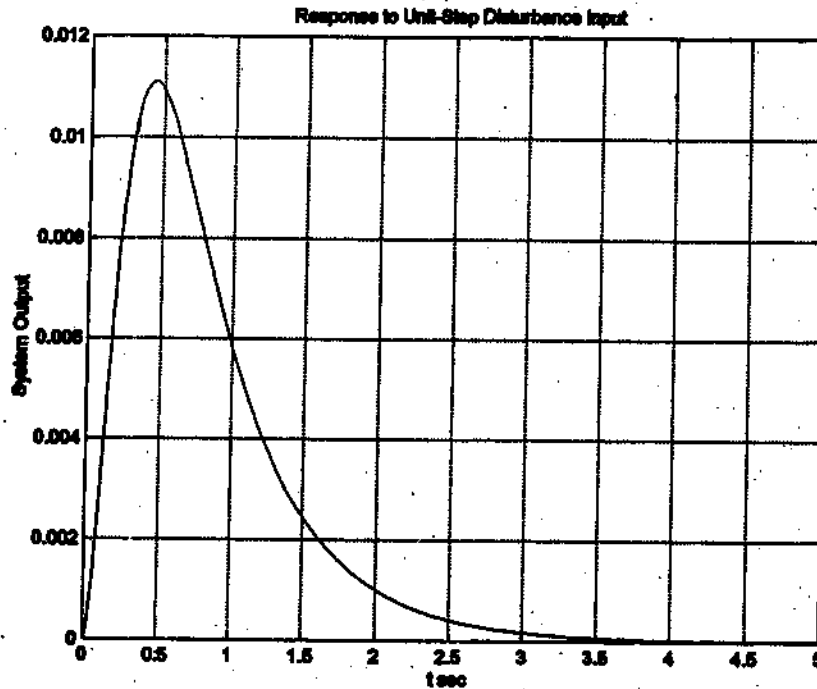

To satisfy the requirements on the responses to the ramp reference input and acceleration reference input, we use the zero-placement approach. That is, we choose the numerator of  $Y(s)/R(s)$  to be the sum of the last three terms of the denominator, or

$$sG_{c1} = 15.7767s^2 + 74.8731s + 88.8331$$

from which we get

$$G_{c1}(s) = \frac{15.7767s^2 + 74.8731s + 88.8331}{s}$$

Hence, the closed-loop transfer function  $Y(s)/R(s)$  becomes as

$$\frac{Y(s)}{R(s)} = \frac{15.7767s^2 + 74.8731s + 88.8331}{s^3 + 15.7767s^2 + 74.8731s + 88.8331}$$

The response curves to the unit-step reference input, unit-ramp reference input, and unit-acceleration reference input are shown on the following two pages.

Notice that the maximum overshoot in the response to the unit-step reference input is 18% and the settling time is approximately 0.7 sec. The steady-state errors in the ramp response and acceleration response are zero. Therefore, the designed controller  $G_c(s)$  is satisfactory.

Finally, we determine  $G_{c2}$ . Noting that

$$G_c(s) = G_{c1}(s) + G_{c2}(s)$$

where

$$G_{c2}(s) = \frac{15.7767s^2 + 74.8731s + 88.8331}{s}$$

and

$$G_{c1}(s) = \frac{15.7767s^2 + 74.8731s + 88.8331}{s}$$

we obtain  $G_{c2}(s) = 0$ . This means that we do not need  $G_{c2}(s)$  to get the desired result.

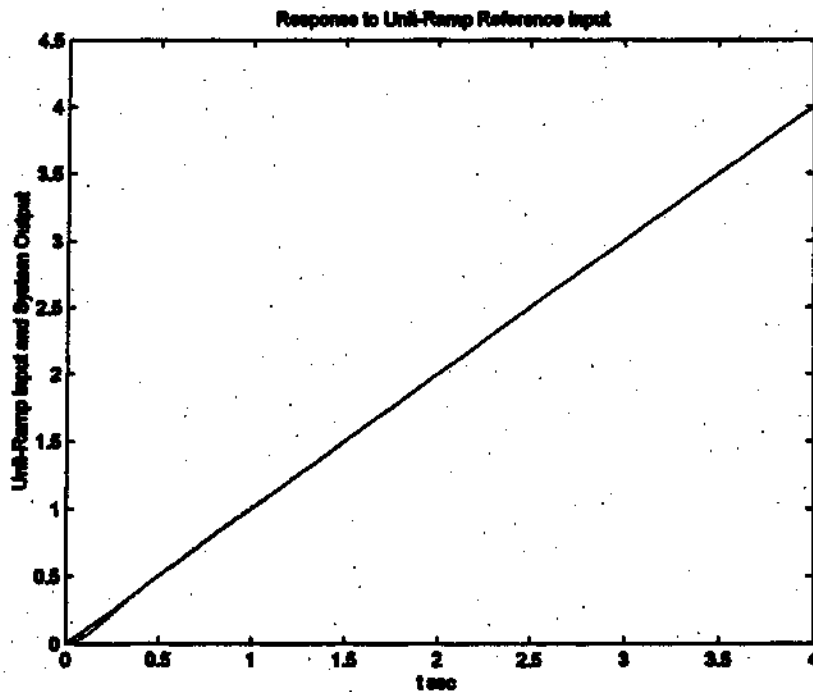
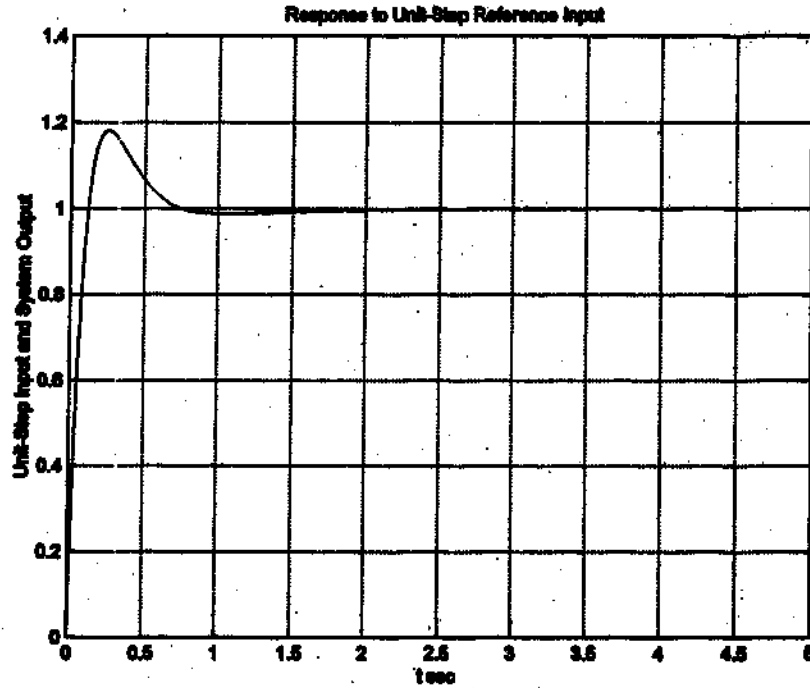

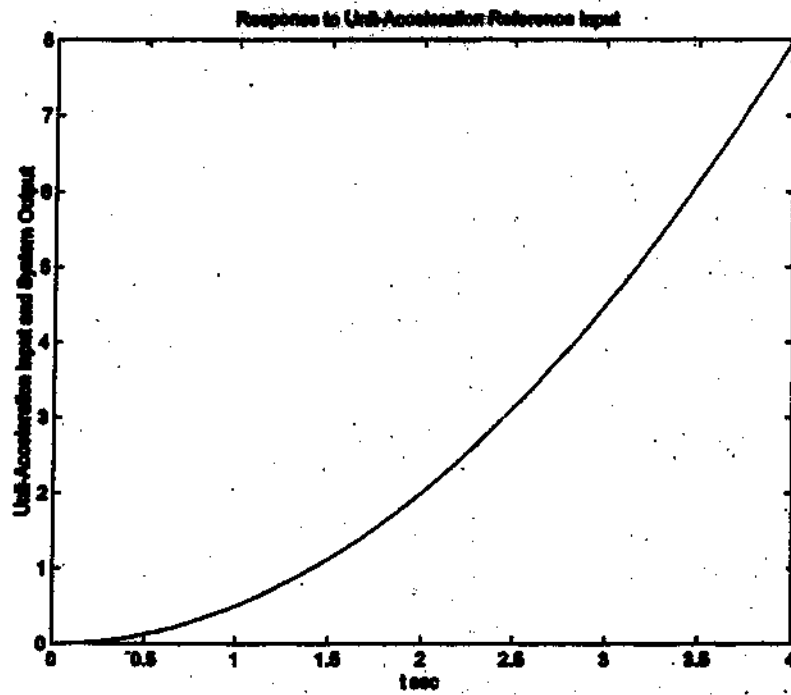

A block diagram of the designed system is shown below.

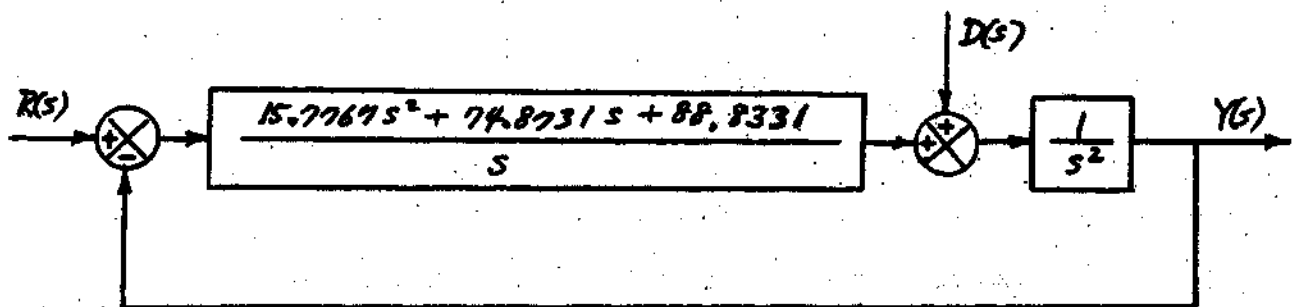

# CHAPTER 11

## B-11-1.

(a) Controllable canonical form:

$$\begin{bmatrix} \dot{x}_1 \\ \dot{x}_2 \end{bmatrix} = \begin{bmatrix} 0 & 1 \\ -6 & -5 \end{bmatrix} \begin{bmatrix} x_1 \\ x_2 \end{bmatrix} + \begin{bmatrix} 0 \\ 1 \end{bmatrix} u$$

$$y = [6 \quad 1] \begin{bmatrix} x_1 \\ x_2 \end{bmatrix}$$

(b) Observable canonical form:

$$\begin{bmatrix} \dot{x}_1 \\ \dot{x}_2 \end{bmatrix} = \begin{bmatrix} 0 & -6 \\ 1 & -5 \end{bmatrix} \begin{bmatrix} x_1 \\ x_2 \end{bmatrix} + \begin{bmatrix} 6 \\ 1 \end{bmatrix} u$$

$$y = [0 \quad 1] \begin{bmatrix} x_1 \\ x_2 \end{bmatrix}$$

B-11-2. The transfer function representation of this system is

$$\frac{Y(s)}{U(s)} = \frac{6}{s^3 + 6s^2 + 11s + 6} = \frac{6}{(s+1)(s+2)(s+3)}$$

The partial-fraction expansion of  $Y(s)/U(s)$  is

$$\frac{Y(s)}{U(s)} = \frac{3}{s+1} + \frac{-6}{s+2} + \frac{3}{s+3}$$

Then, a diagonal canonical form of the system is

$$\begin{bmatrix} \dot{x}_1 \\ \dot{x}_2 \\ \dot{x}_3 \end{bmatrix} = \begin{bmatrix} -1 & 0 & 0 \\ 0 & -2 & 0 \\ 0 & 0 & -3 \end{bmatrix} \begin{bmatrix} x_1 \\ x_2 \\ x_3 \end{bmatrix} + \begin{bmatrix} 1 \\ 1 \\ 1 \end{bmatrix} u$$

$$y = [3 \quad -6 \quad 3] \begin{bmatrix} x_1 \\ x_2 \\ x_3 \end{bmatrix}$$

**B-11-3.** We shall present two methods to obtain the controllable canonical form of the given system equation.

**Method 1:** Referring to Equation (3-29), we have

$$\begin{aligned} G(s) &= \underline{C} (s\underline{I} - \underline{A})^{-1} \underline{B} = [1 \quad 1] \begin{bmatrix} s-1 & -2 \\ 4 & s+3 \end{bmatrix}^{-1} \begin{bmatrix} 1 \\ 2 \end{bmatrix} \\ &= \frac{1}{s^2 + 2s + 5} [1 \quad 1] \begin{bmatrix} s+3 & 2 \\ -4 & s-1 \end{bmatrix} \begin{bmatrix} 1 \\ 2 \end{bmatrix} \\ &= \frac{3s + 1}{s^2 + 2s + 5} = \frac{b_0 s^2 + b_1 s + b_2}{s^2 + a_1 s + a_2} \end{aligned}$$

Hence

$$a_1 = 2, \quad a_2 = 5, \quad b_0 = 0, \quad b_1 = 3, \quad b_2 = 1$$

Then, referring to Equations (11-3) and (11-4), the controllable canonical form of the state and output equations are obtained as

$$\begin{bmatrix} \dot{x}_1 \\ \dot{x}_2 \end{bmatrix} = \begin{bmatrix} 0 & 1 \\ -5 & -2 \end{bmatrix} \begin{bmatrix} x_1 \\ x_2 \end{bmatrix} + \begin{bmatrix} 0 \\ 1 \end{bmatrix} u$$

$$y = [1 \quad 3] \begin{bmatrix} x_1 \\ x_2 \end{bmatrix}$$

**Method 2:** Transform the original state vector  $\underline{x}$  to a new state vector  $\hat{\underline{x}}$  by means of the transformation matrix  $\underline{T}$ , or

$$\underline{x} = \underline{T} \hat{\underline{x}}$$

where

$$\underline{T} = \underline{M} \underline{W} = \begin{bmatrix} \underline{B} & \underline{AB} \end{bmatrix} \begin{bmatrix} a_1 & 1 \\ 1 & 0 \end{bmatrix}$$

Hence,

$$T_m = \begin{bmatrix} 1 & 5 \\ 2 & -10 \end{bmatrix} \begin{bmatrix} 2 & 1 \\ 1 & 0 \end{bmatrix} = \begin{bmatrix} 7 & 1 \\ -6 & 2 \end{bmatrix}$$

and

$$T_m^{-1} = \begin{bmatrix} 0.1 & -0.05 \\ 0.3 & 0.35 \end{bmatrix}$$

The state equation and output equation become

$$\dot{\hat{x}}_m = T_m^{-1} A_m T_m \hat{x}_m + T_m^{-1} B_m u$$

$$y = C_m T_m \hat{x}_m$$

or

$$\begin{bmatrix} \dot{\hat{x}}_1 \\ \dot{\hat{x}}_2 \end{bmatrix} = \begin{bmatrix} 0.1 & -0.05 \\ 0.3 & 0.35 \end{bmatrix} \begin{bmatrix} 1 & 2 \\ -4 & -3 \end{bmatrix} \begin{bmatrix} 7 & 1 \\ -6 & 2 \end{bmatrix} \begin{bmatrix} \hat{x}_1 \\ \hat{x}_2 \end{bmatrix} + \begin{bmatrix} 0.1 & -0.05 \\ 0.3 & 0.35 \end{bmatrix} \begin{bmatrix} 1 \\ 2 \end{bmatrix} u$$

$$= \begin{bmatrix} 0 & 1 \\ -5 & -2 \end{bmatrix} \begin{bmatrix} \hat{x}_1 \\ \hat{x}_2 \end{bmatrix} + \begin{bmatrix} 0 \\ 1 \end{bmatrix} u$$

$$y = \begin{bmatrix} 1 & 1 \\ -6 & 2 \end{bmatrix} \begin{bmatrix} \hat{x}_1 \\ \hat{x}_2 \end{bmatrix} = \begin{bmatrix} 1 & 3 \end{bmatrix} \begin{bmatrix} \hat{x}_1 \\ \hat{x}_2 \end{bmatrix}$$

**B-11-4.** Referring to Equation (3-29), we have

$$G(s) = C_m (sI_m - A_m)^{-1} B_m$$

$$= \begin{bmatrix} 1 & 1 & 0 \end{bmatrix} \begin{bmatrix} s+1 & 0 & -1 \\ -1 & s+2 & 0 \\ 0 & 0 & s+3 \end{bmatrix}^{-1} \begin{bmatrix} 0 \\ 0 \\ 1 \end{bmatrix}$$

$$= \begin{bmatrix} 1 & 1 & 0 \end{bmatrix} \frac{1}{(s+1)(s+2)(s+3)} \begin{bmatrix} (s+2)(s+3) & 0 & s+2 \\ s+3 & (s+1)(s+3) & 1 \\ 0 & 0 & (s+1)(s+2) \end{bmatrix} \begin{bmatrix} 0 \\ 0 \\ 1 \end{bmatrix}$$

$$= \frac{s+3}{(s+1)(s+2)(s+3)} = \frac{s+3}{s^3 + 6s^2 + 11s + 6}$$

Although this is a third-order system, there is a cancellation of  $(s + 3)$  in the numerator and denominator. Hence, the reduced transfer function becomes of second order.

The transfer function expression can be easily obtained from the state-space expression if MATLAB command

$$[\text{num}, \text{den}] = \text{ss2tf}(A, B, C, D)$$

is used. See the following MATLAB output.

```

A = [-1 0 1; 1 -2 0; 0 0 -3];
B = [0; 0; 1];
C = [1 1 0];
D = [0];
[num,den] = ss2tf(A,B,C,D)

num =
      0      0  1.0000  3.0000

den =
      1      6     11      6
```

This output corresponds to the transfer function

$$\frac{s+3}{s^3 + 6s^2 + 11s + 6}$$

Notice that the MATLAB output does not show the reduced transfer function when cancellation occurs.

**B-11-5.** The eigenvalues are

$$\lambda_1 = 1, \lambda_2 = -1, \lambda_3 = j, \lambda_4 = -j$$

The following transformation matrix  $\underline{\underline{P}}$  will give  $\underline{\underline{P}}^{-1}\underline{\underline{A}}\underline{\underline{P}} = \text{diag}(\lambda_1, \lambda_2, \lambda_3, \lambda_4)$ :

$$\underline{\underline{P}} = \begin{bmatrix} 1 & 1 & 1 & 1 \\ \lambda_1 & \lambda_2 & \lambda_3 & \lambda_4 \\ \lambda_1^2 & \lambda_2^2 & \lambda_3^2 & \lambda_4^2 \\ \lambda_1^3 & \lambda_2^3 & \lambda_3^3 & \lambda_4^3 \end{bmatrix} = \begin{bmatrix} 1 & 1 & 1 & 1 \\ 1 & -1 & j & -j \\ 1 & 1 & -1 & -1 \\ 1 & -1 & -j & j \end{bmatrix}$$

This can be seen as follows. Since the inverse of matrix  $\underline{\underline{P}}$  is

$$P^{-1} = \frac{1}{4} \begin{bmatrix} 1 & 1 & 1 & 1 \\ 1 & -1 & 1 & -1 \\ 1 & -j & -1 & j \\ 1 & j & -1 & -j \end{bmatrix}$$

we have

$$P^{-1}AP = \frac{1}{4} \begin{bmatrix} 1 & 1 & 1 & 1 \\ 1 & -1 & 1 & -1 \\ 1 & -j & -1 & j \\ 1 & j & -1 & -j \end{bmatrix} \begin{bmatrix} 0 & 1 & 0 & 0 \\ 0 & 0 & 1 & 0 \\ 0 & 0 & 0 & 1 \\ 1 & 0 & 0 & 0 \end{bmatrix} \begin{bmatrix} 1 & 1 & 1 & 1 \\ 1 & -1 & j & -j \\ 1 & 1 & -1 & -1 \\ 1 & -1 & -j & j \end{bmatrix}$$

$$= \begin{bmatrix} 1 & 0 & 0 & 0 \\ 0 & -1 & 0 & 0 \\ 0 & 0 & j & 0 \\ 0 & 0 & 0 & -j \end{bmatrix}$$

B-11-6.

Method 1:

$$e_m^{At} = \mathcal{L}^{-1} [(sI - A)^{-1}] = \mathcal{L}^{-1} \left\{ \begin{bmatrix} s & -1 \\ 2 & s+3 \end{bmatrix}^{-1} \right\}$$

$$= \mathcal{L}^{-1} \begin{bmatrix} \frac{2}{s+1} - \frac{1}{s+2} & \frac{1}{s+1} - \frac{1}{s+2} \\ -\frac{2}{s+1} + \frac{2}{s+2} & -\frac{1}{s+1} + \frac{2}{s+2} \end{bmatrix}$$

$$= \begin{bmatrix} 2e^{-t} - e^{-2t} & e^{-t} - e^{-2t} \\ -2e^{-t} + 2e^{-2t} & -e^{-t} + 2e^{-2t} \end{bmatrix}$$

Method 2: Referring to Equation (11-46), we have

$$e_{\underline{m}}^{At} = P_{\underline{m}} e_{\underline{m}}^{Dt} P_{\underline{m}}^{-1} = P_{\underline{m}} \begin{bmatrix} e^{\lambda_1 t} & 0 \\ 0 & e^{\lambda_2 t} \end{bmatrix} P_{\underline{m}}^{-1}$$

Since the eigenvalues are  $\lambda_1 = -1$  and  $\lambda_2 = -2$ , we obtain

$$\begin{aligned} e_{\underline{m}}^{At} &= \begin{bmatrix} 1 & 1 \\ -1 & -2 \end{bmatrix} \begin{bmatrix} e^{-t} & 0 \\ 0 & e^{-2t} \end{bmatrix} \begin{bmatrix} 2 & 1 \\ -1 & -1 \end{bmatrix} \\ &= \begin{bmatrix} 2e^{-t} - e^{-2t} & e^{-t} - e^{-2t} \\ -2e^{-t} + 2e^{-2t} & -e^{-t} + 2e^{-2t} \end{bmatrix} \end{aligned}$$

Method 3: Referring to Equation (11-47), we have

$$\begin{vmatrix} 1 & \lambda_1 & e^{\lambda_1 t} \\ 1 & \lambda_2 & e^{\lambda_2 t} \\ \underline{I}_{\underline{m}} & \underline{A}_{\underline{m}} & e_{\underline{m}}^{At} \end{vmatrix} = 0_{\underline{m}}$$

or

$$\begin{vmatrix} 1 & -1 & e^{-t} \\ 1 & -2 & e^{-2t} \\ \underline{I}_{\underline{m}} & \underline{A}_{\underline{m}} & e_{\underline{m}}^{At} \end{vmatrix} = 0_{\underline{m}}$$

which can be rewritten as

$$-e_{\underline{m}}^{At} + (\underline{A}_{\underline{m}} + 2\underline{I}_{\underline{m}}) e^{-t} - e^{-2t} \underline{I}_{\underline{m}} = \underline{A}_{\underline{m}} e^{-2t}$$

Thus

$$\begin{aligned} e_{\underline{m}}^{At} &= (\underline{A}_{\underline{m}} + 2\underline{I}_{\underline{m}}) e^{-t} - e^{-2t} \underline{I}_{\underline{m}} - e^{-2t} \underline{A}_{\underline{m}} \\ &= \begin{bmatrix} 2 & 1 \\ -2 & -1 \end{bmatrix} e^{-t} - \begin{bmatrix} 1 & 0 \\ 0 & 1 \end{bmatrix} e^{-2t} - \begin{bmatrix} 0 & 1 \\ -2 & -3 \end{bmatrix} e^{-2t} \\ &= \begin{bmatrix} 2e^{-t} - e^{-2t} & e^{-t} - e^{-2t} \\ -2e^{-t} + 2e^{-2t} & -e^{-t} + 2e^{-2t} \end{bmatrix} \end{aligned}$$

**B-11-7.** The given state matrix is in the Jordan canonical form. The eigenvalues are

$$\lambda_1 = 2, \quad \lambda_2 = 2, \quad \lambda_3 = 2$$

Since

$$e^{At} = \begin{bmatrix} e^{2t} & te^{2t} & \frac{1}{2}t^2e^{2t} \\ 0 & e^{2t} & te^{2t} \\ 0 & 0 & e^{2t} \end{bmatrix}$$

we have

$$\underline{x}(t) = e^{At} \underline{x}(0)$$

or

$$\begin{bmatrix} x_1(t) \\ x_2(t) \\ x_3(t) \end{bmatrix} = \begin{bmatrix} e^{2t} & te^{2t} & \frac{1}{2}t^2e^{2t} \\ 0 & e^{2t} & te^{2t} \\ 0 & 0 & e^{2t} \end{bmatrix} \begin{bmatrix} x_1(0) \\ x_2(0) \\ x_3(0) \end{bmatrix}$$

**B-11-8.**

$$A = \begin{bmatrix} 0 & 1 \\ -3 & -2 \end{bmatrix}$$

$$|sI - A| = \begin{vmatrix} s & -1 \\ 3 & s+2 \end{vmatrix} = s^2 + 2s + 3 = (s+1+j\sqrt{2})(s+1-j\sqrt{2})$$

$$e^{At} = \mathcal{L}^{-1} [(sI - A)^{-1}] = \mathcal{L}^{-1} \left\{ \begin{bmatrix} s & -1 \\ 3 & s+2 \end{bmatrix}^{-1} \right\}$$

$$= \mathcal{L}^{-1} \left\{ \frac{1}{s(s+2)+3} \begin{bmatrix} s+2 & 1 \\ -3 & s \end{bmatrix} \right\}$$

$$= \mathcal{L}^{-1} \begin{bmatrix} \frac{s+1+1}{(s+1)^2 + \sqrt{2}^2} & \frac{1}{(s+1)^2 + \sqrt{2}^2} \\ \frac{-3}{(s+1)^2 + \sqrt{2}^2} & \frac{s+1-1}{(s+1)^2 + \sqrt{2}^2} \end{bmatrix}$$

$$= \mathcal{L}^{-1} \left[ \begin{array}{cc} \frac{s+1}{(s+1)^2 + \sqrt{2}^2} + \frac{1}{\sqrt{2}} \frac{\sqrt{2}}{(s+1)^2 + \sqrt{2}^2} & \frac{1}{\sqrt{2}} \frac{\sqrt{2}}{(s+1)^2 + \sqrt{2}^2} \\ -\frac{3}{\sqrt{2}} \frac{\sqrt{2}}{(s+1)^2 + \sqrt{2}^2} & \frac{s+1}{(s+1)^2 + \sqrt{2}^2} - \frac{1}{\sqrt{2}} \frac{\sqrt{2}}{(s+1)^2 + \sqrt{2}^2} \end{array} \right]$$

$$= \begin{bmatrix} e^{-t} \cos \sqrt{2}t + \frac{1}{\sqrt{2}} e^{-t} \sin \sqrt{2}t & \frac{1}{\sqrt{2}} e^{-t} \sin \sqrt{2}t \\ -\frac{3}{\sqrt{2}} e^{-t} \sin \sqrt{2}t & e^{-t} \cos \sqrt{2}t - \frac{1}{\sqrt{2}} e^{-t} \sin \sqrt{2}t \end{bmatrix}$$

Hence

$$\underline{x}(t) = e^{\underline{A}t} \underline{x}(0) = e^{\underline{A}t} \begin{bmatrix} 1 \\ -1 \end{bmatrix}$$

$$= \begin{bmatrix} e^{-t} \cos \sqrt{2}t \\ -e^{-t} \cos \sqrt{2}t - \sqrt{2} e^{-t} \sin \sqrt{2}t \end{bmatrix}$$

B-11-9. Define

$$\underline{A} = \begin{bmatrix} -6 & 1 & 0 \\ -11 & 0 & 1 \\ -6 & 0 & 0 \end{bmatrix}, \quad \underline{B} = \begin{bmatrix} 2 \\ 6 \\ 2 \end{bmatrix}, \quad \underline{C} = [1 \ 0 \ 0]$$

Define also the transformation matrix as  $\underline{P}$  such that  $\underline{x} = \underline{P}\underline{z}$ .

$$\underline{x} = \underline{P}\underline{z} = \begin{bmatrix} p_{11} & p_{12} & p_{13} \\ p_{21} & p_{22} & p_{23} \\ p_{31} & p_{32} & p_{33} \end{bmatrix} \begin{bmatrix} z_1 \\ z_2 \\ z_3 \end{bmatrix}$$

Then with this transformation the state equation and output equation:

$$\dot{\underline{x}} = \underline{A}\underline{x} + \underline{B}u$$

$$y = \underline{C}\underline{x}$$

can be written as

$$\dot{\underline{z}} = \underline{P}^{-1}\underline{A}\underline{P}\underline{z} + \underline{P}^{-1}\underline{B}u$$

$$y = \underline{C}\underline{P}\underline{z}$$

In this problem it is specified that

$$P^{-1}AP = \begin{bmatrix} 0 & 0 & -6 \\ 1 & 0 & -11 \\ 0 & 1 & -6 \end{bmatrix} \quad P^{-1}B = \begin{bmatrix} 1 \\ 0 \\ 0 \end{bmatrix}$$

Thus

$$B = P \begin{bmatrix} 1 \\ 0 \\ 0 \end{bmatrix} = \begin{bmatrix} p_{11} & p_{12} & p_{13} \\ p_{21} & p_{22} & p_{23} \\ p_{31} & p_{32} & p_{33} \end{bmatrix} \begin{bmatrix} 1 \\ 0 \\ 0 \end{bmatrix} = \begin{bmatrix} p_{11} \\ p_{21} \\ p_{31} \end{bmatrix} = \begin{bmatrix} 2 \\ 6 \\ 2 \end{bmatrix}$$

Hence

$$P = \begin{bmatrix} 2 & p_{12} & p_{13} \\ 6 & p_{22} & p_{23} \\ 2 & p_{32} & p_{33} \end{bmatrix}$$

Since

$$AP = P \begin{bmatrix} 0 & 0 & -6 \\ 1 & 0 & -11 \\ 0 & 1 & -6 \end{bmatrix}$$

we have

$$\begin{bmatrix} -6 & 1 & 0 \\ -11 & 0 & 1 \\ -6 & 0 & 0 \end{bmatrix} \begin{bmatrix} 2 & p_{12} & p_{13} \\ 6 & p_{22} & p_{23} \\ 2 & p_{32} & p_{33} \end{bmatrix} = \begin{bmatrix} 2 & p_{12} & p_{13} \\ 6 & p_{22} & p_{23} \\ 2 & p_{32} & p_{33} \end{bmatrix} \begin{bmatrix} 0 & 0 & -6 \\ 1 & 0 & -11 \\ 0 & 1 & -6 \end{bmatrix}$$

or

$$\begin{bmatrix} -12+6 & -6p_{12}+p_{22} & -6p_{13}+p_{23} \\ -22+2 & -11p_{12}+p_{32} & -11p_{13}+p_{33} \\ -12 & -6p_{12} & -6p_{13} \end{bmatrix} = \begin{bmatrix} p_{12} & p_{13} & -12-11p_{12}-6p_{13} \\ p_{22} & p_{23} & -36-11p_{22}-6p_{23} \\ p_{32} & p_{33} & -12-11p_{32}-6p_{33} \end{bmatrix}$$

from which we obtain

$$p_{12} = -6, \quad p_{22} = -20, \quad p_{32} = -12$$

and

$$-6p_{12} + p_{22} = p_{12}$$

$$-6p_{13} + p_{23} = -12 - 11p_{12} - 6p_{13}$$

$$-11p_{12} + p_{32} = p_{23}$$

$$-11 p_{13} + p_{33} = -36 - 11 p_{22} - 6 p_{23}$$

$$-6 p_{12} = p_{33}$$

$$-6 p_{13} = -12 - 11 p_{22} - 6 p_{23}$$

Solving the last six equations for  $p_{13}$ ,  $p_{23}$ , and  $p_{33}$  we find

$$p_{13} = 16, \quad p_{23} = 54, \quad p_{33} = 36$$

Hence

$$P = \begin{bmatrix} 2 & -6 & 16 \\ 6 & -20 & 54 \\ 2 & -12 & 36 \end{bmatrix}$$

We thus determined the necessary transformation matrix  $P$ . The output equation becomes

$$y = CPz = [2 \quad -6 \quad 16] \begin{bmatrix} z_1 \\ z_2 \\ z_3 \end{bmatrix}$$

Alternative approach: An alternative approach to the solution of this problem is given below. Since the characteristic equation for the system is

$$\begin{aligned} |sI - A| &= \begin{vmatrix} s+6 & -1 & 0 \\ 11 & s & -1 \\ 6 & 0 & s \end{vmatrix} = s^3 + 6s^2 + 11s + 6 \\ &= s^3 + a_1 s^2 + a_2 s + a_3 \end{aligned}$$

we find

$$a_1 = 6, \quad a_2 = 11, \quad a_3 = 6$$

Define

$$M = \begin{bmatrix} B & AB & A^2B \\ B & AB & A^2B \end{bmatrix} = \begin{bmatrix} 2 & -6 & 16 \\ 6 & -20 & 54 \\ 2 & -12 & 36 \end{bmatrix}$$

Then

$$M^{-1} = \begin{bmatrix} 9 & -3 & 0.5 \\ 13.5 & -5 & 1.5 \\ 4 & -1.5 & 0.5 \end{bmatrix}$$

It can be shown that

$$M^{-1}AM = \begin{bmatrix} 0 & 0 & -a_3 \\ 1 & 0 & -a_2 \\ 0 & 1 & -a_1 \end{bmatrix} = \begin{bmatrix} 0 & 0 & -6 \\ 1 & 0 & -11 \\ 0 & 1 & -6 \end{bmatrix} \quad M^{-1}B = \begin{bmatrix} 1 \\ 0 \\ 0 \end{bmatrix}$$

Also

$$CM = [1 \ 0 \ 0] \begin{bmatrix} 2 & -6 & 16 \\ 6 & -20 & 54 \\ 2 & -12 & 36 \end{bmatrix} = [2 \ -6 \ 16]$$

Hence, by use of the following transformation:

$$x = Mz = \begin{bmatrix} 2 & -6 & 16 \\ 6 & -20 & 54 \\ 2 & -12 & 36 \end{bmatrix} \begin{bmatrix} z_1 \\ z_2 \\ z_3 \end{bmatrix}$$

the given system

$$\begin{aligned} \dot{x} &= Ax + Bu \\ y &= Cx \end{aligned}$$

can be transformed into

$$\begin{aligned} \dot{z} &= M^{-1}AMz + M^{-1}Bu \\ y &= CMz \end{aligned}$$

or

$$\begin{bmatrix} \dot{z}_1 \\ \dot{z}_2 \\ \dot{z}_3 \end{bmatrix} = \begin{bmatrix} 0 & 0 & -6 \\ 1 & 0 & -11 \\ 0 & 1 & -6 \end{bmatrix} \begin{bmatrix} z_1 \\ z_2 \\ z_3 \end{bmatrix} + \begin{bmatrix} 1 \\ 0 \\ 0 \end{bmatrix} u$$

$$y = [2 \ -6 \ 16] \begin{bmatrix} z_1 \\ z_2 \\ z_3 \end{bmatrix}$$

**B-11-10.** A MATLAB program to obtain a state-space representation is given next.

```

num = [0 10.4 47 160];
den = [1 14 56 160];
[A,B,C,D] = tf2ss(num,den)

```

A =

```

-14 -56 -160
  1  0  0
  0  1  0

```

B =

```

  1
  0
  0

```

C =

```

10.4000 47.0000 160.0000

```

D =

```

  0

```

The state-space representation is

$$\begin{bmatrix} \dot{x}_1 \\ \dot{x}_2 \\ \dot{x}_3 \end{bmatrix} = \begin{bmatrix} -14 & -56 & -160 \\ 1 & 0 & 0 \\ 0 & 1 & 0 \end{bmatrix} \begin{bmatrix} x_1 \\ x_2 \\ x_3 \end{bmatrix} + \begin{bmatrix} 1 \\ 0 \\ 0 \end{bmatrix} u$$

$$y = \begin{bmatrix} 10.4 & 47 & 160 \end{bmatrix} \begin{bmatrix} x_1 \\ x_2 \\ x_3 \end{bmatrix} + 0 u$$

B-11-11.

```

A = [0 1 0;-1 -1 0;1 0 0];
B = [0;1;0];
C = [0 0 1];
D = [0];
[num,den] = ss2tf(A,B,C,D)

```

num =

```

  0  0  0.0000  1.0000

```

den =

```

1.0000 1.0000 1.0000  0

```

The transfer function representation of the system is

$$\frac{Y(s)}{U(s)} = \frac{1}{s^3 + s^2 + s}$$

B-11-12.

```

A = [2 1 0; 0 2 0; 0 1 3];
B = [0 1; 1 0; 0 1];
C = [1 0 0];
D = [0 0];
[NUM,den] = ss2tf(A,B,C,D,1)

NUM =
    0    0    1   -3

den =
    1   -7   16  -12

[NUM,den] = ss2tf(A,B,C,D,2)

NUM =
    0    1   -5    6

den =
    1   -7   16  -12
    
```

The transfer function representation of the system consists of two equations:

$$\frac{Y(s)}{U_1(s)} = \frac{s-3}{s^3 - 7s^2 + 16s - 12}$$

$$\frac{Y(s)}{U_2(s)} = \frac{s^2 - 5s + 6}{s^3 - 7s^2 + 16s - 12}$$

B-11-13. The controllability and observability of the system can be determined by examining the rank conditions of

$$\begin{bmatrix} B & AB & A^2B \\ m & m & m \end{bmatrix}$$

and

$$\begin{bmatrix} C^* & A^*C^* & (A^*)^2C^* \\ m & m & m \end{bmatrix}$$

respectively.

```

A = [-1 -2 -2; 0 -1 1; 0 -1];
B = [2; 0; 1];
C = [1 1 0];
D = [0];
rank([B A*B A^2*B])

ans =

    3

rank([C' A'*C' A'^2*C'])

ans =

    3

```

Since the rank of  $[B \quad AB \quad A^2B]$  is 3 and the rank of  $[C' \quad A'C' \quad A'^2C']$  is also 3, the system is completely state controllable and observable.

B-11-14.

```

A = [2 0 0; 0 2 0; 0 3 1];
B = [0 1; 1 0; 0 1];
C = [1 0 0; 0 1 0];
D = [0 0; 0 0];
rank([B A*B A^2*B])

ans =

    3

rank([C' A'*C' A'^2*C'])

ans =

    2

rank([C*B C*A*B C*A^2*B])

ans =

    2

```

From the rank conditions obtained above, the system is completely state controllable but not completely observable. It is completely output controllable. Note that the condition of the output controllability is that the rank of

$$\begin{bmatrix} C & B & CA & CB \\ C & A & B & CA^2B \\ C & A^2 & B & CA^2B \end{bmatrix}$$

be  $m$  (the dimension of the output vector, which is 2 in the present system).

B-11-15.

$$\begin{aligned} A &= [0 \ 1 \ 0; 0 \ 0 \ 1; -6 \ -11 \ -6]; \\ B &= [0; 0; 1]; \\ C &= [20 \ 9 \ 1]; \\ D &= [0]; \\ \text{rank}([B \ A \cdot B \ A^2 \cdot B]) & \\ \text{ans} &= \\ & 3 \\ \text{rank}([C' \ A' \cdot C' \ A'^2 \cdot C']) & \\ \text{ans} &= \\ & 3 \end{aligned}$$

Since the rank of  $[B \ AB \ A^2B]$  is 3 and that of  $[C' \ A'C' \ A'^2C']$  is also 3, the system is completely state controllable and completely observable.

B-11-16.

$$\underline{A} = \begin{bmatrix} 0 & 1 & 0 \\ 0 & 0 & 1 \\ -6 & -11 & -6 \end{bmatrix}, \quad \underline{B} = \begin{bmatrix} 0 \\ 0 \\ 1 \end{bmatrix}, \quad \underline{C} = [c_1 \ c_2 \ c_3]$$

The observability matrix is

$$[\underline{C}' \ \underline{A}' \underline{C}' \ \underline{A}'^2 \underline{C}'] = \begin{bmatrix} c_1 & -6c_3 & -6(c_2 - 6c_3) \\ c_2 & c_1 - 11c_3 & -11c_2 + 60c_3 \\ c_3 & c_2 - 6c_3 & c_1 - 6c_2 + 25c_3 \end{bmatrix}$$

There are infinitely many sets of  $c_1$ ,  $c_2$ , and  $c_3$  that will make the system unobservable. Examples of such a set of  $c_1$ ,  $c_2$ , and  $c_3$  are

$$\underline{C} = [1 \ 1 \ 0]$$

$$\underline{C} = [1 \ 1 \ \frac{2}{9}]$$

$$\underline{C} = [6 \ 5 \ 1]$$

$$\underline{C} = [1 \ 1 \ \frac{1}{6}]$$

etc.

With any of these matrices  $\underline{C}$  the rank of the observability matrix becomes less than 3 and the system becomes unobservable.

B-11-17.

(a)

$$A = \begin{bmatrix} 2 & 0 & 0 \\ 0 & 2 & 0 \\ 0 & 3 & 1 \end{bmatrix}, \quad C = [1 \quad 1 \quad 1]$$

The rank of

$$\begin{bmatrix} C^* & A^*C^* & A^{*2}C^* \end{bmatrix} = \begin{bmatrix} 1 & 2 & 4 \\ 1 & 5 & 13 \\ 1 & 1 & 1 \end{bmatrix}$$

is two, because

$$\begin{vmatrix} 1 & 2 & 4 \\ 1 & 5 & 13 \\ 1 & 1 & 1 \end{vmatrix} = 0, \quad \begin{vmatrix} 1 & 2 \\ 1 & 5 \end{vmatrix} = 3$$

Hence, the system is not completely observable.

(b) If the output vector is given by

$$\begin{bmatrix} y_1 \\ y_2 \end{bmatrix} = \begin{bmatrix} 1 & 1 & 1 \\ 1 & 2 & 3 \end{bmatrix} \begin{bmatrix} x_1 \\ x_2 \\ x_3 \end{bmatrix} = \hat{C}_m x$$

then the rank of

$$\begin{bmatrix} \hat{C}_m^* & A^* \hat{C}_m^* & A^{*2} \hat{C}_m^* \end{bmatrix} = \begin{bmatrix} 1 & 1 & 2 & 2 & 4 & 4 \\ 1 & 2 & 5 & 13 & 13 & 35 \\ 1 & 3 & 1 & 3 & 1 & 3 \end{bmatrix}$$

is three, because the determinant of a 3 x 3 matrix consisting of the first, fourth, and sixth column is

$$\begin{vmatrix} 1 & 2 & 4 \\ 1 & 13 & 35 \\ 1 & 3 & 3 \end{vmatrix} = -42$$

Since the rank of  $\begin{bmatrix} \hat{C}_m^* & A^* \hat{C}_m^* & A^{*2} \hat{C}_m^* \end{bmatrix}$  is 3, the system is completely observable. A MATLAB solution to this problem is given on the next page.

A = [2 0 0; 0 2 0; 0 3 1];

C = [1 1 1];

rank([C' A'\*C' A'^2\*C'])

ans =

2

A = [2 0 0; 0 2 0; 0 3 1];

C = [1 1 1; 2 3];

rank([C' A'\*C' A'^2\*C'])

ans =

3

# CHAPTER 12

**B-12-1.** Referring to Equation (3-29), we have

$$\begin{aligned}
 G(s) &= C(sI - A)^{-1}B = [1 \ 1 \ 0] \begin{bmatrix} s+1 & 0 & -1 \\ -1 & s+2 & 0 \\ 0 & 0 & s+3 \end{bmatrix}^{-1} \begin{bmatrix} 0 \\ 0 \\ 1 \end{bmatrix} \\
 &= \frac{1}{(s+1)(s+2)(s+3)} [1 \ 1 \ 0] \begin{bmatrix} (s+2)(s+3) & 0 & s+2 \\ s+3 & (s+1)(s+3) & 1 \\ 0 & 0 & (s+1)(s+2) \end{bmatrix} \begin{bmatrix} 0 \\ 0 \\ 1 \end{bmatrix} \\
 &= \frac{s+3}{(s+1)(s+2)(s+3)} = \frac{s+3}{s^3 + 6s^2 + 11s + 6} \quad (1)
 \end{aligned}$$

Comparing this transfer function with

$$\frac{b_0 s^3 + b_1 s^2 + b_2 s + b_3}{s^3 + a_1 s^2 + a_2 s + a_3}$$

we obtain

$$\begin{aligned}
 a_1 &= 6, \quad a_2 = 11, \quad a_3 = 6 \\
 b_0 &= 0, \quad b_1 = 0, \quad b_2 = 1, \quad b_3 = 3
 \end{aligned}$$

(a) Controllable canonical form: Referring to Equations (11-3) and (11-4), we have

$$\begin{bmatrix} \dot{x}_1 \\ \dot{x}_2 \\ \dot{x}_3 \end{bmatrix} = \begin{bmatrix} 0 & 1 & 0 \\ 0 & 0 & 1 \\ -6 & -11 & -6 \end{bmatrix} \begin{bmatrix} x_1 \\ x_2 \\ x_3 \end{bmatrix} + \begin{bmatrix} 0 \\ 0 \\ 1 \end{bmatrix} u \quad (2)$$

$$y = [3 \ 1 \ 0] \begin{bmatrix} x_1 \\ x_2 \\ x_3 \end{bmatrix} \quad (3)$$

Note that because of the cancellation of the terms  $(s + 3)$  in the transfer function, the system defined by Equations (2) and (3) is state controllable, but not observable.

(b) Observable canonical form: Referring to Equations (11-5) and (11-6), we have

$$\begin{bmatrix} \dot{x}_1 \\ \dot{x}_2 \\ \dot{x}_3 \end{bmatrix} = \begin{bmatrix} 0 & 0 & -6 \\ 1 & 0 & -11 \\ 0 & 1 & -6 \end{bmatrix} \begin{bmatrix} x_1 \\ x_2 \\ x_3 \end{bmatrix} + \begin{bmatrix} 3 \\ 1 \\ 0 \end{bmatrix} u \quad (4)$$

$$y = \begin{bmatrix} 0 & 0 & 1 \end{bmatrix} \begin{bmatrix} x_1 \\ x_2 \\ x_3 \end{bmatrix} \quad (5)$$

Because of the cancellation of the terms  $(s + 3)$  in the transfer function given by Equation (1), the system defined by Equations (4) and (5) is observable, but not state controllable.

It is important to note that when cancellation of the numerator and denominator of the transfer function occurs [see Equation (1)], the system becomes controllable but not observable or observable but not controllable depending on how one writes the state and output equations.

B-12-2.

$$\begin{aligned} G(s) &= \underset{m}{C} (\underset{m}{sI} - \underset{m}{A})^{-1} \underset{m}{B} = \begin{bmatrix} 1 & 1 & 1 \end{bmatrix} \begin{bmatrix} s+1 & 0 & -1 \\ -1 & s+2 & 0 \\ 0 & 0 & s+3 \end{bmatrix}^{-1} \begin{bmatrix} 0 \\ 1 \\ 1 \end{bmatrix} \\ &= \frac{1}{(s+1)(s+2)(s+3)} \begin{bmatrix} 1 & 1 & 1 \end{bmatrix} \begin{bmatrix} (s+2)(s+3) & 0 & s+2 \\ s+3 & (s+1)(s+3) & 1 \\ 0 & 0 & (s+1)(s+2) \end{bmatrix} \begin{bmatrix} 0 \\ 1 \\ 1 \end{bmatrix} \\ &= \frac{2s^2 + 8s + 8}{(s+1)(s+2)(s+3)} = \frac{2s^2 + 8s + 8}{s^3 + 6s^2 + 11s + 6} \end{aligned}$$

Comparing this transfer function with

$$\frac{b_0 s^3 + b_1 s^2 + b_2 s + b_3}{s^3 + a_1 s^2 + a_2 s + a_3}$$

we obtain

$$a_1 = 6, \quad a_2 = 11, \quad a_3 = 6$$

$$b_0 = 0, \quad b_1 = 2, \quad b_2 = 8, \quad b_3 = 8$$

Referring to Equations (11-5) and (11-6), we have the state-space equations in the following observable canonical form:

$$\begin{bmatrix} \dot{x}_1 \\ \dot{x}_2 \\ \dot{x}_3 \end{bmatrix} = \begin{bmatrix} 0 & 0 & -6 \\ 1 & 0 & -11 \\ 0 & 1 & -6 \end{bmatrix} \begin{bmatrix} x_1 \\ x_2 \\ x_3 \end{bmatrix} + \begin{bmatrix} 8 \\ 8 \\ 2 \end{bmatrix}$$

$$y = \begin{bmatrix} 0 & 0 & 1 \end{bmatrix} \begin{bmatrix} x_1 \\ x_2 \\ x_3 \end{bmatrix}$$

**B-12-3.** Referring to Equation (12-18), the state-feedback gain matrix  $K$  can be given by

$$K = [0 \ 0 \ 1] \begin{bmatrix} B & AB & A^2B \end{bmatrix}^{-1} \phi(A)$$

where

$$\phi(A) = A^3 + \alpha_1 A^2 + \alpha_2 A + \alpha_3 I$$

The values of  $\alpha_1$ ,  $\alpha_2$ , and  $\alpha_3$  are determined from the desired characteristic equation:

$$\begin{aligned} |sI - (A - BK)| &= (s + 2 + j4)(s + 2 - j4)(s + 10) \\ &= s^3 + 14s^2 + 60s + 200 \\ &= s^3 + \alpha_1 s^2 + \alpha_2 s + \alpha_3 \end{aligned}$$

Thus,

$$\alpha_1 = 14, \quad \alpha_2 = 60, \quad \alpha_3 = 200$$

Then

$$\phi(A) = \begin{bmatrix} 0 & 1 & 0 \\ 0 & 0 & 1 \\ -1 & -5 & -6 \end{bmatrix}^3 + 14 \begin{bmatrix} 0 & 1 & 0 \\ 0 & 0 & 1 \\ -1 & -5 & -6 \end{bmatrix}^2 + 60 \begin{bmatrix} 0 & 1 & 0 \\ 0 & 0 & 1 \\ -1 & -5 & -6 \end{bmatrix} + 200 \begin{bmatrix} 1 & 0 & 0 \\ 0 & 1 & 0 \\ 0 & 0 & 1 \end{bmatrix}$$

$$= \begin{bmatrix} 199 & 55 & 8 \\ -8 & 159 & 7 \\ -7 & -43 & 117 \end{bmatrix}$$

Since

$$\begin{bmatrix} B & AB & A^2B \\ \underline{m} & \underline{m} & \underline{m} \end{bmatrix} = \begin{bmatrix} 0 & 1 & 1 \\ 1 & 1 & -11 \\ 1 & -11 & 60 \end{bmatrix}$$

we have the desired state-feedback gain matrix  $\underline{K}$  as follows:

$$\begin{aligned} \underline{K} &= [0 \ 0 \ 1] \begin{bmatrix} 0 & 1 & 1 \\ 1 & 1 & -11 \\ 1 & -11 & 60 \end{bmatrix}^{-1} \begin{bmatrix} 199 & 55 & 8 \\ -8 & 159 & 7 \\ -7 & -43 & 117 \end{bmatrix} \\ &= [0 \ 0 \ 1] \begin{bmatrix} 0.7349 & 0.8554 & 0.1446 \\ 0.8554 & 0.0120 & -0.0120 \\ 0.1446 & -0.0120 & 0.0120 \end{bmatrix} \\ &\quad \times \begin{bmatrix} 199 & 55 & 8 \\ -8 & 159 & 7 \\ -7 & -43 & 117 \end{bmatrix} \\ &= [0 \ 0 \ 1] \begin{bmatrix} 138.3976 & 170.2169 & 28.7831 \\ 170.2169 & 48.4819 & 5.5181 \\ 28.7831 & 5.5181 & 2.4819 \end{bmatrix} \\ &= [28.7831 \quad 5.5181 \quad 2.4819] \end{aligned}$$

---

B-12-4. MATLAB programs to obtain the state-feedback gain matrix  $K$  by use of the command "acker" or command "place" are shown on the next page.

```
% ***** Generating matrix K by use of command "acker" *****
```

```
A = [0 1 0; 0 0 1; -1 -5 -6];
```

```
B = [0; 1; 1];
```

```
J = [-2+j*4 -2-j*4 -10];
```

```
K = acker(A,B,J)
```

```
K =
```

```
28.7831 5.5181 2.4819
```

```
% ***** Generating matrix K by use of command "place" *****
```

```
A = [0 1 0; 0 0 1; -1 -5 -6];
```

```
B = [0; 1; 1];
```

```
J = [-2+j*4 -2-j*4 -10];
```

```
K = place(A,B,J)
```

```
place: ndigits=15
```

```
K =
```

```
28.7831 5.5181 2.4819
```

**B-12-5. Substituting**

$$u = -Kx = - \begin{bmatrix} k_1 & k_2 \end{bmatrix} \begin{bmatrix} x_1 \\ x_2 \end{bmatrix}$$

into the state equation, we obtain

$$\begin{aligned} \begin{bmatrix} \dot{x}_1 \\ \dot{x}_2 \end{bmatrix} &= \begin{bmatrix} 0 & 1 \\ 0 & 2 \end{bmatrix} \begin{bmatrix} x_1 \\ x_2 \end{bmatrix} + \begin{bmatrix} 1 \\ 0 \end{bmatrix} u \\ &= \begin{bmatrix} 0 & 1 \\ 0 & 2 \end{bmatrix} \begin{bmatrix} x_1 \\ x_2 \end{bmatrix} - \begin{bmatrix} 1 \\ 0 \end{bmatrix} \begin{bmatrix} k_1 & k_2 \end{bmatrix} \begin{bmatrix} x_1 \\ x_2 \end{bmatrix} \\ &= \begin{bmatrix} -k_1 & 1-k_2 \\ 0 & 2 \end{bmatrix} \begin{bmatrix} x_1 \\ x_2 \end{bmatrix} \end{aligned}$$

The characteristic equation becomes

$$|s\mathbf{I} - \mathbf{A}| = \begin{vmatrix} s+k_1 & -1+k_2 \\ 0 & s-2 \end{vmatrix} = (s+k_1)(s-2) = 0$$

Because of the presence of one eigenvalue ( $s = 2$ ) in the right-half  $s$  plane, the system is unstable whatever values  $k_1$  and  $k_2$  may assume.

B-12-6. Since

$$\frac{Y(s)}{U(s)} = \frac{10}{(s+1)(s+2)(s+3)} = \frac{10}{s^3 + 6s^2 + 11s + 6}$$

we have

$$\ddot{y} + 6\dot{y} + 11y + 6y = 10u$$

Using the state variables as defined in the problem statement, the state equation becomes

$$\begin{bmatrix} \dot{x}_1 \\ \dot{x}_2 \\ \dot{x}_3 \end{bmatrix} = \begin{bmatrix} 0 & 1 & 0 \\ 0 & 0 & 1 \\ -6 & -11 & -6 \end{bmatrix} \begin{bmatrix} x_1 \\ x_2 \\ x_3 \end{bmatrix} + \begin{bmatrix} 0 \\ 0 \\ 10 \end{bmatrix} u$$

Thus

$$A = \begin{bmatrix} 0 & 1 & 0 \\ 0 & 0 & 1 \\ -6 & -11 & -6 \end{bmatrix}, \quad B = \begin{bmatrix} 0 \\ 0 \\ 10 \end{bmatrix}$$

Referring to Equation (12-18), the state-feedback gain matrix  $\mathbf{K}$  can be given by

$$\mathbf{K} = [0 \ 0 \ 1] [\mathbf{B} \ \mathbf{AB} \ \mathbf{A}^2\mathbf{B}]^{-1} \phi(\mathbf{A})$$

where

$$\phi(\mathbf{A}) = \mathbf{A}^3 + \alpha_1 \mathbf{A}^2 + \alpha_2 \mathbf{A} + \alpha_3 \mathbf{I}$$

The values of  $\alpha_1$ ,  $\alpha_2$ , and  $\alpha_3$  are determined from the desired characteristic equation:

$$|s\mathbf{I} - (\mathbf{A} - \mathbf{BK})| = (s+2+j2\sqrt{3})(s+2-j2\sqrt{3})(s+10)$$

$$= s^3 + 14s^2 + 56s + 160$$

$$= s^3 + \alpha_1 s^2 + \alpha_2 s + \alpha_3$$

Thus

$$\alpha_1 = 14, \quad \alpha_2 = 56, \quad \alpha_3 = 160$$

Hence,

$$\begin{aligned} \phi(A) &= \begin{bmatrix} 0 & 1 & 0 \\ 0 & 0 & 1 \\ -6 & -11 & -6 \end{bmatrix}^3 + 14 \begin{bmatrix} 0 & 1 & 0 \\ 0 & 0 & 1 \\ -6 & -11 & -6 \end{bmatrix}^2 + 56 \begin{bmatrix} 0 & 1 & 0 \\ 0 & 0 & 1 \\ -6 & -11 & -6 \end{bmatrix} \\ &\quad + 160 \begin{bmatrix} 1 & 0 & 0 \\ 0 & 1 & 0 \\ 0 & 0 & 1 \end{bmatrix} \\ &= \begin{bmatrix} 154 & 45 & 8 \\ -48 & 66 & -3 \\ 18 & -15 & 84 \end{bmatrix} \end{aligned}$$

Since

$$\begin{bmatrix} B & AB & A^2B \\ m & mm & mm \end{bmatrix} = \begin{bmatrix} 0 & 0 & 10 \\ 0 & 10 & -60 \\ 10 & -60 & 250 \end{bmatrix}$$

we have

$$K_m = \begin{bmatrix} 0 & 0 & 1 \end{bmatrix} \begin{bmatrix} 0 & 0 & 10 \\ 0 & 10 & -60 \\ 10 & -60 & 250 \end{bmatrix}^{-1} \begin{bmatrix} 154 & 45 & 8 \\ -48 & 66 & -3 \\ 18 & -15 & 84 \end{bmatrix}$$

$$= \begin{bmatrix} 0 & 0 & 1 \end{bmatrix} \begin{bmatrix} 1.1 & 0.6 & 0.1 \\ 0.6 & 0.1 & 0 \\ 0.1 & 0 & 0 \end{bmatrix} \begin{bmatrix} 154 & 45 & 8 \\ -48 & 66 & -3 \\ 18 & -15 & 84 \end{bmatrix}$$

$$= \begin{bmatrix} 0 & 0 & 1 \end{bmatrix} \begin{bmatrix} 142.4 & 87.6 & 15.4 \\ 87.6 & 33.6 & 4.5 \\ 15.4 & 4.5 & 0.8 \end{bmatrix}$$

$$= \begin{bmatrix} 15.4 & 4.5 & 0.8 \end{bmatrix}$$

---

**B-12-7.** A MATLAB solution of Problem B-12-6 is given on the next page.

% \*\*\*\*\* Generating matrix K by use of command "acker" \*\*\*\*\*

```
A=[0 1 0;0 0 1;-6 -11 -6];
B=[0;0;10];
J=[-2+j*2*(sqrt(3)) -2-j*2*(sqrt(3)) -10];
K=acker(A,B,J)
```

K=

15.4000 4.5000 0.8000

B-12-8. From Figure 12-49 we obtain

$$u = k_1(r - x_1) - k_2 x_2 - k_3 x_3 = -Kx + k_1 r$$

where

$$K = [k_1 \quad k_2 \quad k_3]$$

Noting that the rank of

$$M = \begin{bmatrix} B & AB & A^2B \\ m & m & m \end{bmatrix} = \begin{bmatrix} 0 & 0 & 1 \\ 0 & 1 & -6 \\ 1 & -6 & 31 \end{bmatrix}$$

is three, arbitrary pole placement is possible. The characteristic equation for this system is

$$\begin{aligned} |sI - A| &= \begin{vmatrix} s & -1 & 0 \\ 0 & s & -1 \\ 0 & 5 & s+6 \end{vmatrix} = s^3 + 6s^2 + 5s \\ &= s^3 + a_1 s^2 + a_2 s + a_3 = 0 \end{aligned}$$

Hence

$$a_1 = 6, \quad a_2 = 5, \quad a_3 = 0$$

Since the state equation for the system is already in the controllable canonical form, we have  $T = I$ . The desired characteristic equation is

$$\begin{aligned} (s+2+j4)(s+2-j4)(s+10) &= s^3 + 14s^2 + 60s + 200 \\ &= s^3 + \alpha_1 s^2 + \alpha_2 s + \alpha_3 \end{aligned}$$

from which we obtain

$$\alpha_1 = 14, \quad \alpha_2 = 60, \quad \alpha_3 = 200$$

Then

$$\begin{aligned} K_m &= [\alpha_3 - a_3 \quad \alpha_2 - a_2 \quad \alpha_1 - a_1] T^{-1} \\ &= [200 - 0 \quad 60 - 5 \quad 14 - 6] I_m \\ &= [200 \quad 55 \quad 8] \end{aligned}$$

The state equation for the designed system is

$$\begin{aligned} \dot{x}_m &= A_m x_m + B_m u = A_m x_m + B_m (-K_m x_m + k_1 r) \\ &= (A_m - B_m K_m) x_m + B_m k_1 r \end{aligned}$$

Since

$$A_m - B_m K_m = \begin{bmatrix} 0 & 1 & 0 \\ 0 & 0 & 1 \\ 0 & -5 & -6 \end{bmatrix} - \begin{bmatrix} 0 \\ 0 \\ 1 \end{bmatrix} [200 \quad 55 \quad 8] = \begin{bmatrix} 0 & 1 & 0 \\ 0 & 0 & 1 \\ -200 & -60 & -14 \end{bmatrix}$$

we have

$$\begin{bmatrix} \dot{x}_1 \\ \dot{x}_2 \\ \dot{x}_3 \end{bmatrix} = \begin{bmatrix} 0 & 1 & 0 \\ 0 & 0 & 1 \\ -200 & -60 & -14 \end{bmatrix} \begin{bmatrix} x_1 \\ x_2 \\ x_3 \end{bmatrix} + \begin{bmatrix} 0 \\ 0 \\ 200 \end{bmatrix} r \quad (1)$$

The output equation is

$$y = [1 \quad 0 \quad 0] \begin{bmatrix} x_1 \\ x_2 \\ x_3 \end{bmatrix} \quad (2)$$

The unit-step response of the designed system can be obtained from Equations (1) and (2) by substituting  $r = 1(t)$  and finding  $y(t)$ . A MATLAB program to obtain the unit-step response curve [ $y(t)$  versus  $t$  curve] is given on the next page.

```

% ***** Unit-step response *****
A = [0 1 0; 0 0 1; -200 -60 -14];
B = [0; 0; 200];
C = [1 0 0];
D = [0];
step(A,B,C,D)
grid
title('Unit-Step Response of Designed System')

```

The resulting unit-step response curve is shown below.

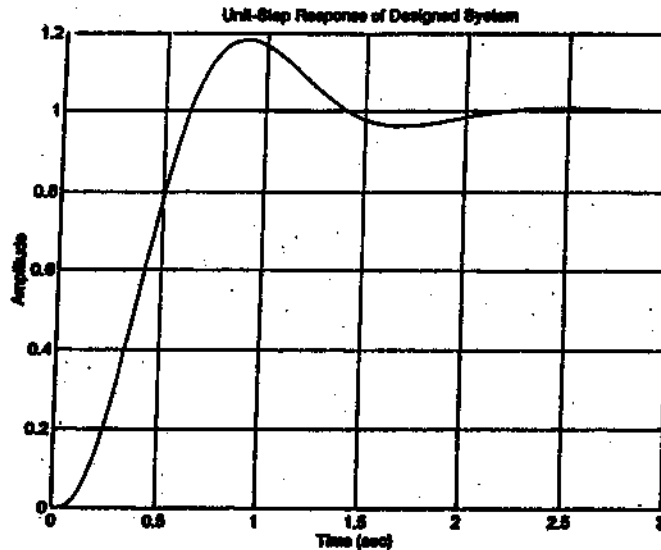

**B-12-9.**

Derivation of the state-space equations for the system: Referring to Section 12-4, a mathematical model for the inverted pendulum system shown in Figure 12-50 is given by

$$(M+m)\ddot{x} + mL\ddot{\theta} = u$$

$$mL^2\ddot{\theta} + mL\ddot{x} = mgL\theta$$

which can be modified to

$$ML\ddot{\theta} = (M+m)g\theta - u$$

$$M\ddot{x} = u - mg\theta$$

Since the state variables are defined as

$$x_1 = \theta, \quad x_2 = \dot{\theta}, \quad x_3 = x, \quad x_4 = \dot{x}$$

we get the following state space equations:

$$\begin{bmatrix} \dot{x}_1 \\ \dot{x}_2 \\ \dot{x}_3 \\ \dot{x}_4 \end{bmatrix} = \begin{bmatrix} 0 & 1 & 0 & 0 \\ \frac{M+m}{Ml}g & 0 & 0 & 0 \\ 0 & 0 & 0 & 1 \\ -\frac{m}{M}g & 0 & 0 & 0 \end{bmatrix} \begin{bmatrix} x_1 \\ x_2 \\ x_3 \\ x_4 \end{bmatrix} + \begin{bmatrix} 0 \\ -\frac{1}{Ml} \\ 0 \\ \frac{1}{M} \end{bmatrix} u \quad (1)$$

$$\begin{bmatrix} y_1 \\ y_2 \end{bmatrix} = \begin{bmatrix} 1 & 0 & 0 & 0 \\ 0 & 0 & 1 & 0 \end{bmatrix} \begin{bmatrix} x_1 \\ x_2 \\ x_3 \\ x_4 \end{bmatrix} \quad (2)$$

Substituting the given numerical values into Equations (1) and (2), we obtain the following state-space equations for the system:

$$\begin{bmatrix} \dot{x}_1 \\ \dot{x}_2 \\ \dot{x}_3 \\ \dot{x}_4 \end{bmatrix} = \begin{bmatrix} 0 & 1 & 0 & 0 \\ 12.2625 & 0 & 0 & 0 \\ 0 & 0 & 0 & 1 \\ -2.4525 & 0 & 0 & 0 \end{bmatrix} \begin{bmatrix} x_1 \\ x_2 \\ x_3 \\ x_4 \end{bmatrix} + \begin{bmatrix} 0 \\ -0.5 \\ 0 \\ 0.5 \end{bmatrix} u$$

$$\begin{bmatrix} y_1 \\ y_2 \end{bmatrix} = \begin{bmatrix} 1 & 0 & 0 & 0 \\ 0 & 0 & 1 & 0 \end{bmatrix} \begin{bmatrix} x_1 \\ x_2 \\ x_3 \\ x_4 \end{bmatrix}$$

Determination of the state-feedback gain matrix K: Since matrices A and B for this system are

$$A = \begin{bmatrix} 0 & 1 & 0 & 0 \\ 12.2625 & 0 & 0 & 0 \\ 0 & 0 & 0 & 1 \\ -2.4525 & 0 & 0 & 0 \end{bmatrix}, \quad B = \begin{bmatrix} 0 \\ -0.5 \\ 0 \\ 0.5 \end{bmatrix}$$

and the desired closed-loop poles are at

$$s = -2 + j4, \quad s = -2 - j4, \quad s = -20, \quad s = -20$$

the following MATLAB program can be written for the determination of the state-feedback gain matrix  $K$ .

```

% ***** State feedback gain matrix K *****

A=[0 1 0 0;12.2625 0 0 0;0 0 0 1;-2.4525 0 0 0];
B=[0;-0.5;0;0.5];
J=[-4+j*4 -4-j*4 -20 -20];
K=acker(A,B,J)

K=

1.0e+003 *

-4.1381 -1.0094 -2.6096 -0.9134
    
```

Obtaining system response to initial condition: To obtain the system response to the initial condition, we first substitute

$$u = -Kx$$

into the system equation

$$\dot{x} = Ax + Bu$$

and get the following equation:

$$\dot{x} = (A - BK)x$$

which, when the numerical values are substituted, can be given by

$$\begin{bmatrix} \dot{x}_1 \\ \dot{x}_2 \\ \dot{x}_3 \\ \dot{x}_4 \end{bmatrix} = \begin{bmatrix} 0 & 0.001 & 0 & 0 \\ -2.0568 & -0.5047 & -1.3048 & -0.4567 \\ 0 & 0 & 0 & 0.001 \\ 2.0666 & 0.5047 & 1.3048 & 0.4567 \end{bmatrix} \begin{bmatrix} x_1 \\ x_2 \\ x_3 \\ x_4 \end{bmatrix} \quad (3)$$

Let us rewrite Equation (3) as

$$\dot{x} = \hat{A}x$$

where

$$\hat{A} = \begin{bmatrix} 0 & 0.001 & 0 & 0 \\ -2.0568 & -0.5047 & -1.3048 & -0.4567 \\ 0 & 0 & 0 & 0.001 \\ 2.0666 & 0.5047 & 1.3048 & 0.4567 \end{bmatrix}$$

Define the initial condition vector as  $\hat{B}$ , or

$$\hat{B} = \begin{bmatrix} 0 \\ 0 \\ 0 \\ 1 \end{bmatrix}$$

Then, the response of the system to the initial condition can be obtained by solving the following equations:

$$\dot{z} = \hat{A} z + \hat{B} u$$

$$x = \hat{A} z + \hat{B} u$$

The following MATLAB program will generate the response of the system to the initial condition. In the MATLAB program we used the following notations:

$$\hat{A} = AA, \quad \hat{B} = BB$$

```
% ---- Response to initial condition ----
% ***** This program obtains the response of the system
% xdot = (Ahat)x to the given initial condition x(0) *****
% ***** Enter matrices A, B, and K to produce matrix
% AA = Ahat *****
A = [0 1 0 0;12.2625 0 0 0;0 0 0 1;-2.4525 0 0 0];
B = [0;-0.5;0;0.5];
K = [-4138.1 -1009.4 -2609.6 -913.4];
AA = A - B*K;
% ***** Enter the initial condition matrix BB = Bhat *****
BB = [0;0;0;1];
[x,z,t] = step(AA,BB,AA,BB);
x1 = [1 0 0 0]*x';
x2 = [0 1 0 0]*x';
x3 = [0 0 1 0]*x';
x4 = [0 0 0 1]*x';
% ***** Plot response curves x1 versus t, x2 versus t; x3 versus t,
% and x4 versus t on one diagram *****
subplot(2,2,1);
plot(t,x1);grid
title('x1 (Theta) versus t')
xlabel('t Sec')
ylabel('x1 = Theta')
subplot(2,2,2);
plot(t,x2);grid
title('x2 (Theta dot) versus t')
xlabel('t Sec')
ylabel('x2 = Theta dot')
```

```

subplot(2,2,3);
plot(t,x3);grid
title('x3 (Displacement of Cart) versus t')
xlabel('t Sec')
ylabel('x3 = Displacement of Cart')

```

```

subplot(2,2,4);
plot(t,x4);grid
title('x4 (Velocity of Cart) versus t')
xlabel('t Sec')
ylabel('x4 = Velocity of Cart')

```

The resulting response curves are shown below.

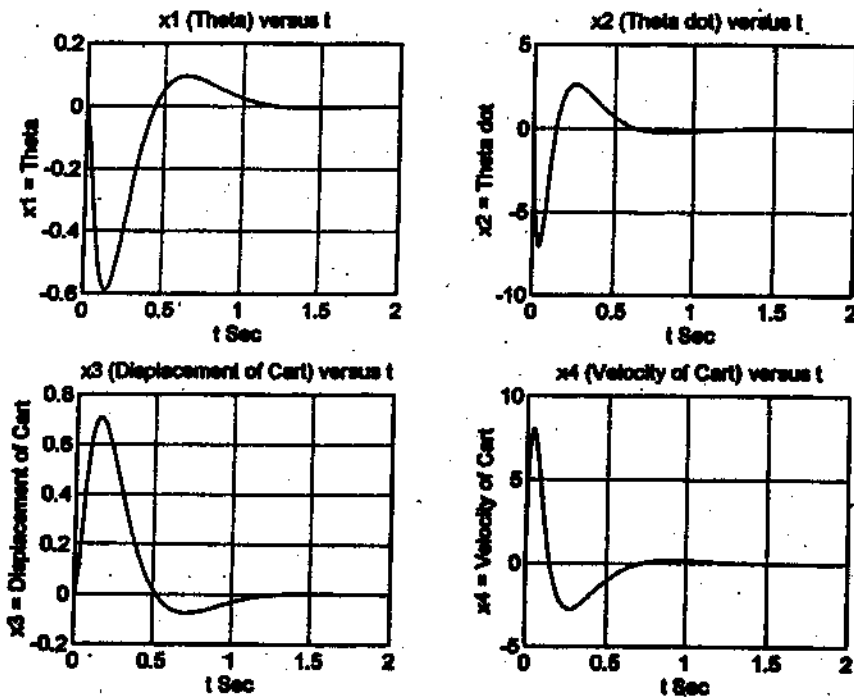

**B-12-10.** We shall present three methods for the design of the full-order state observer.

**Method 1:** We shall first transform the system equations into the observable canonical form. Define a transformation matrix  $Q$  by

$$Q = (WN^*)^{-1}$$

where

$$N = \begin{bmatrix} C^* & A^*C^* \\ \vdots & \vdots \end{bmatrix} = \begin{bmatrix} 1 & -1 \\ 0 & 1 \end{bmatrix}$$

and

$$W = \begin{bmatrix} a_1 & 1 \\ 1 & 0 \end{bmatrix}$$

where  $a_1$  is a coefficient in the characteristic equation of the original state equation:

$$\begin{aligned} |sI - A| &= \begin{vmatrix} s+1 & -1 \\ -1 & s+2 \end{vmatrix} = s^2 + 3s + 1 \\ &= s^2 + a_1s + a_2 \end{aligned}$$

Thus

$$a_1 = 3, \quad a_2 = 1$$

and

$$W = \begin{bmatrix} 3 & 1 \\ 1 & 0 \end{bmatrix}$$

Hence

$$Q^{-1} = W N^* = \begin{bmatrix} 3 & 1 \\ 1 & 0 \end{bmatrix} \begin{bmatrix} 1 & 0 \\ -1 & 1 \end{bmatrix} = \begin{bmatrix} 2 & 1 \\ 1 & 0 \end{bmatrix}$$

and

$$Q = \begin{bmatrix} 0 & 1 \\ 1 & -2 \end{bmatrix}$$

Define a new state vector  $\xi$  by

$$x = Q \xi$$

Then, the state and output equations become

$$\begin{aligned} \dot{\xi} &= Q^{-1} A Q \xi \\ y &= C Q \xi \end{aligned}$$

where

$$\begin{aligned} Q^{-1} A Q &= \begin{bmatrix} 2 & 1 \\ 1 & 0 \end{bmatrix} \begin{bmatrix} -1 & 1 \\ 1 & -2 \end{bmatrix} \begin{bmatrix} 0 & 1 \\ 1 & -2 \end{bmatrix} = \begin{bmatrix} 0 & -1 \\ 1 & -3 \end{bmatrix} \\ C Q &= \begin{bmatrix} 1 & 0 \end{bmatrix} \begin{bmatrix} 0 & 1 \\ 1 & -2 \end{bmatrix} = \begin{bmatrix} 0 & 1 \end{bmatrix} \end{aligned}$$

The new state and output equations are in the observable canonical form. Referring to Equation (12-61), the state observer gain matrix  $K_e$  can be given by

$$K_e = Q \begin{bmatrix} \alpha_2 - a_2 \\ \alpha_1 - a_1 \end{bmatrix}$$

where  $\alpha_1$  and  $\alpha_2$  are determined from the desired characteristic equation:

$$(s-\mu_1)(s-\mu_2) = (s+5)(s+5) = s^2 + 10s + 25$$

$$= s^2 + \alpha_1 s + \alpha_2 = 0$$

as

$$\alpha_1 = 10, \quad \alpha_2 = 25$$

Hence,

$$K_e = \begin{bmatrix} 0 & 1 \\ 1 & -2 \end{bmatrix} \begin{bmatrix} 25-1 \\ 10-3 \end{bmatrix} = \begin{bmatrix} 7 \\ 10 \end{bmatrix}$$

Method 2: Define

$$K_e = \begin{bmatrix} k_{e1} \\ k_{e2} \end{bmatrix}$$

Then, the characteristic equation of the observer is

$$\begin{vmatrix} sI - A + K_e C \\ \hline \hline \end{vmatrix} = \begin{vmatrix} s+1+k_{e1} & -1 \\ -1+k_{e2} & s+2 \end{vmatrix}$$

$$= s^2 + (1+k_{e1}+2)s + 1 + 2k_{e1} + k_{e2}$$

$$= s^2 + 10s + 25$$

Hence

$$1+k_{e1}+2=10, \quad 1+2k_{e1}+k_{e2}=25$$

or

$$k_{e1} = 7, \quad k_{e2} = 10$$

Thus,

$$K_e = \begin{bmatrix} 7 \\ 10 \end{bmatrix}$$

Method 3: Next, we shall obtain the observer gain matrix  $K_e$  by use of Ackermann's formula given by Equation (12-65):

$$K_e = \phi(A) \begin{bmatrix} C \\ \hline CA \end{bmatrix}^{-1} \begin{bmatrix} 0 \\ 1 \end{bmatrix}$$

where  $\phi(s)$  is the desired characteristic polynomial, or

$$\phi(s) = (s-\mu_1)(s-\mu_2) = (s+5)(s+5) = s^2 + 10s + 25$$

Hence

$$\begin{aligned}\phi(\underline{A}) &= \underline{A}^2 + 10\underline{A} + 25\underline{I} \\ &= \begin{bmatrix} -1 & 1 \\ 1 & -2 \end{bmatrix}^2 + 10 \begin{bmatrix} -1 & 1 \\ 1 & -2 \end{bmatrix} + 25 \begin{bmatrix} 1 & 0 \\ 0 & 1 \end{bmatrix} = \begin{bmatrix} 17 & 7 \\ 7 & 10 \end{bmatrix}\end{aligned}$$

Thus

$$\underline{K}_e = \begin{bmatrix} 17 & 7 \\ 7 & 10 \end{bmatrix} \begin{bmatrix} 1 & 0 \\ -1 & 1 \end{bmatrix}^{-1} \begin{bmatrix} 0 \\ 1 \end{bmatrix} = \begin{bmatrix} 17 & 7 \\ 7 & 10 \end{bmatrix} \begin{bmatrix} 1 & 0 \\ 1 & 1 \end{bmatrix} \begin{bmatrix} 0 \\ 1 \end{bmatrix} = \begin{bmatrix} 7 \\ 10 \end{bmatrix}$$

The equation for the full-order state observer is given by Equation (12-60):

$$\dot{\tilde{\underline{x}}} = (\underline{A} - \underline{K}_e \underline{C}) \tilde{\underline{x}} + \underline{B}u + \underline{K}_e y$$

where  $\underline{B} = \underline{0}$  in this problem. Hence

$$\begin{bmatrix} \dot{\tilde{x}}_1 \\ \dot{\tilde{x}}_2 \end{bmatrix} = \left\{ \begin{bmatrix} -1 & 1 \\ 1 & -2 \end{bmatrix} - \begin{bmatrix} 7 \\ 10 \end{bmatrix} \begin{bmatrix} 1 & 0 \end{bmatrix} \right\} \begin{bmatrix} \tilde{x}_1 \\ \tilde{x}_2 \end{bmatrix} + \begin{bmatrix} 7 \\ 10 \end{bmatrix} y$$

or

$$\begin{bmatrix} \dot{\tilde{x}}_1 \\ \dot{\tilde{x}}_2 \end{bmatrix} = \begin{bmatrix} -8 & 1 \\ -9 & -2 \end{bmatrix} \begin{bmatrix} \tilde{x}_1 \\ \tilde{x}_2 \end{bmatrix} + \begin{bmatrix} 7 \\ 10 \end{bmatrix} y$$

This is the equation for the full-order state observer.

---

**B-12-11.** A full-order state observer for the given system is designed by use of MATLAB. The MATLAB program used for the design of the state observer is given below.

```
% ***** Design of full-order state observer *****  
A=[0 1 0;0 0 1;-5 -6 0];  
C=[1 0 0];  
L=[-10 -10 -15];  
Ke=acker(A',C,L)  
Warning: Pole locations are more than 10% in error.  
  
Ke =  
  
    35  
    394  
   1285
```

Referring to Equation (12-60), the full-order state observer is given by

$$\dot{\tilde{x}}_m = (A_m - K_m C_m) \tilde{x}_m + B_m u + K_m y$$

$$\begin{bmatrix} \dot{\tilde{x}}_1 \\ \dot{\tilde{x}}_2 \\ \dot{\tilde{x}}_3 \end{bmatrix} = \begin{bmatrix} -35 & 1 & 0 \\ -394 & 0 & 1 \\ -1290 & -6 & 0 \end{bmatrix} \begin{bmatrix} \tilde{x}_1 \\ \tilde{x}_2 \\ \tilde{x}_3 \end{bmatrix} + \begin{bmatrix} 0 \\ 0 \\ 1 \end{bmatrix} u + \begin{bmatrix} 35 \\ 394 \\ 1285 \end{bmatrix} y$$

**B-12-12.** We shall present two methods for obtaining the full-order state observer gain matrix  $K_m$ . A MATLAB solution is also given.

Method 1: Referring to Equation (12-61), the state observer gain matrix  $K_m$  can be given by

$$K_m = Q \begin{bmatrix} \alpha_3 - a_3 \\ \alpha_2 - a_2 \\ \alpha_1 - a_1 \end{bmatrix}$$

Matrix  $Q$  is given by

$$Q_m = (W N_m^*)^{-1}$$

where

$$N_m = \begin{bmatrix} C_m^* & A_m^* C_m^* & A_m^{*2} C_m^* \end{bmatrix} = \begin{bmatrix} 1 & 0 & 0 \\ 0 & 1 & 0 \\ 0 & 0 & 1 \end{bmatrix} = I_m$$

$$W_m = \begin{bmatrix} a_2 & a_1 & 1 \\ a_1 & 1 & 0 \\ 1 & 0 & 0 \end{bmatrix}$$

The values of  $a_1$  and  $a_2$  are determined from the characteristic equation of the original system.

$$\begin{aligned} |sI_m - A_m| &= \begin{vmatrix} s & -1 & 0 \\ 0 & s & -1 \\ -1.244 & -0.3956 & s+3.145 \end{vmatrix} \\ &= s^3 + 3.145s^2 - 0.3956s - 1.244 \\ &= s^3 + a_1 s^2 + a_2 s + a_3 \end{aligned}$$

Hence

$$a_1 = 3.145, \quad a_2 = -0.3956, \quad a_3 = -1.244$$

Thus

$$W_m = \begin{bmatrix} -0.3956 & 3.145 & 1 \\ 3.145 & 1 & 0 \\ 1 & 0 & 0 \end{bmatrix}$$

Therefore

$$Q_m = (W_m N_m^*)^{-1} = \begin{bmatrix} -0.3956 & 3.145 & 1 \\ 3.145 & 1 & 0 \\ 1 & 0 & 0 \end{bmatrix}^{-1} = \begin{bmatrix} 0 & 0 & 1 \\ 0 & 1 & -3.145 \\ 1 & -3.145 & 10.2866 \end{bmatrix}$$

The values of  $\alpha_1$ ,  $\alpha_2$ , and  $\alpha_3$  are determined from the desired characteristic equation.

$$\begin{aligned} & (s - \mu_1)(s - \mu_2)(s - \mu_3) \\ &= (s + 5 - j5\sqrt{3})(s + 5 + j5\sqrt{3})(s + 10) \\ &= (s^2 + 10s + 100)(s + 10) \\ &= s^3 + 20s^2 + 200s + 1000 \\ &= s^3 + \alpha_1 s^2 + \alpha_2 s + \alpha_3 = 0 \end{aligned}$$

Thus

$$\alpha_1 = 20, \quad \alpha_2 = 200, \quad \alpha_3 = 1000$$

Hence

$$\begin{aligned} K_m &= Q_m \begin{bmatrix} \alpha_3 - a_3 \\ \alpha_2 - a_2 \\ \alpha_1 - a_1 \end{bmatrix} = \begin{bmatrix} 0 & 0 & 1 \\ 0 & 1 & -3.145 \\ 1 & -3.145 & 10.2866 \end{bmatrix} \begin{bmatrix} 1000 + 1.244 \\ 200 + 0.3956 \\ 20 - 3.145 \end{bmatrix} \\ &= \begin{bmatrix} 16.855 \\ 147.387 \\ 544.381 \end{bmatrix} \end{aligned}$$

Method 2: Define the state observer gain matrix as

$$K_m = \begin{bmatrix} k_{e1} \\ k_{e2} \\ k_{e3} \end{bmatrix}$$

The desired characteristic equation becomes

$$\begin{aligned}
|sI - A + K_e C| &= \left| \begin{bmatrix} s & 0 & 0 \\ 0 & s & 0 \\ 0 & 0 & s \end{bmatrix} - \begin{bmatrix} 0 & 1 & 0 \\ 0 & 0 & 1 \\ 1.244 & 0.3956 & -3.145 \end{bmatrix} + \begin{bmatrix} k_1 \\ k_2 \\ k_3 \end{bmatrix} \begin{bmatrix} 1 & 0 & 0 \end{bmatrix} \right| \\
&= \begin{vmatrix} s+k_1 & -1 & 0 \\ k_2 & s & -1 \\ -1.244+k_3 & -0.3956 & s+3.145 \end{vmatrix} \\
&= s^3 + (k_1 + 3.145)s^2 + (3.145k_1 + k_2 - 0.3956)s \\
&\quad + (-1.244 + k_3 + 3.145k_2 - 0.3956k_1) \\
&= s^3 + 20s^2 + 200s + 1000 = 0
\end{aligned}$$

Hence

$$k_1 + 3.145 = 20$$

$$3.145k_1 + k_2 - 0.3956 = 200$$

$$-1.244 + k_3 + 3.145k_2 - 0.3956k_1 = 1000$$

from which we obtain

$$k_1 = 16.855, \quad k_2 = 147.387, \quad k_3 = 544.381$$

or

$$K_e = \begin{bmatrix} 16.855 \\ 147.387 \\ 544.381 \end{bmatrix}$$

Referring to Equation (12-60), the full-order state observer is

$$\dot{\tilde{x}} = (A - K_e C)\tilde{x} + Bu + K_e y$$

or

$$\begin{bmatrix} \dot{\tilde{x}}_1 \\ \dot{\tilde{x}}_2 \\ \dot{\tilde{x}}_3 \end{bmatrix} = \begin{bmatrix} -16.855 & 1 & 0 \\ -147.387 & 0 & 1 \\ -543.137 & 0.3956 & -3.145 \end{bmatrix} \begin{bmatrix} \tilde{x}_1 \\ \tilde{x}_2 \\ \tilde{x}_3 \end{bmatrix} + \begin{bmatrix} 0 \\ 0 \\ 1.244 \end{bmatrix} u + \begin{bmatrix} 16.855 \\ 147.387 \\ 544.381 \end{bmatrix} y$$

**MATLAB solution:** A MATLAB program to obtain the state observer gain matrix  $K_e$  is shown on the next page.

```

% ***** Design of full-order state observer *****
A=[0 1 0;0 0 1;1.244 0.3956 -3.145];
C=[1 0 0];
L=[-5+j*5*(sqrt(3)) -5-j*5*(sqrt(3)) -10];
Ke=acker(A',C,L)

Ke =
    16.8550
   147.3866
   544.3809

```

B-12-13.

$$\begin{bmatrix} \dot{x}_1 \\ \dot{x}_2 \end{bmatrix} = \begin{bmatrix} 0 & 1 \\ 0 & 0 \end{bmatrix} \begin{bmatrix} x_1 \\ x_2 \end{bmatrix} + \begin{bmatrix} 0 \\ 1 \end{bmatrix} u$$

$$y = \begin{bmatrix} 1 & 0 \end{bmatrix} \begin{bmatrix} x_1 \\ x_2 \end{bmatrix}$$

The desired closed-loop poles for the pole-placement part are

$$s = -0.7071 \pm j0.7071$$

and the desired observer pole of the minimum-order observer is at

$$s = -5$$

The first step to design a observer controller is to determine the state feedback gain matrix  $K$  and the observer gain matrix  $K_e$ . By using the MATLAB program given below we can determine  $K$  and  $K_e$ .

```

% ***** Determination of K and Ke *****
A=[0 1;0 0];
B=[0;1];
J=[-0.7071+j*0.7071 -0.7071-j*0.7071];
K=acker(A,B,J)

K =
    1.0000    1.4142

Abb=[0];
Aab=[1];
L=[-5];
Ke=acker(Abb',Aab',L)

Ke =
    5

```

The feedback gain matrix  $\underline{K}$  and the observer gain matrix  $K_e$  are obtained as follows:

$$\underline{K} = [1 \quad 1.4142] , \quad K_e = 5$$

Next, we obtain the transfer function of the observer controller. Noting that the minimum-order observer equation is given by Equation (12-89), we have

$$\dot{\tilde{z}} = (A_{bb} - K_e A_{ab}) \tilde{z} + [(A_{bb} - K_e A_{ab}) K_e + A_{ba} - K_e A_{aa}] y + (B_b - K_e B_a) u$$

For the present system,

$$A_{aa} = 0, \quad A_{ab} = 1, \quad A_{ba} = 0, \quad A_{bb} = 0, \quad B_a = 0, \quad B_b = 1$$

$$K_a = 1, \quad K_b = 1.4142, \quad K_c = 5$$

By substituting these numerical values into the minimum-order observer equation, we get

$$\dot{\tilde{z}} = (0 - 5 \times 1) \tilde{z} + [(0 - 5 \times 1) 5 + 0 - 5 \times 0] y + (1 - 5 \times 0) u$$

or

$$\dot{\tilde{z}} = -5 \tilde{z} - 25 y + u$$

Taking the Laplace transform of the last equation, assuming the zero initial condition, we have

$$s \tilde{z}(s) = -5 \tilde{z}(s) - 25 Y(s) + U(s)$$

or

$$\tilde{z}(s) = \frac{1}{s+5} [-25 Y(s) + U(s)] \quad (1)$$

Referring to Equation (12-104) we have

$$\begin{aligned} u &= -\underline{K} \underline{\tilde{x}} = -K_b \tilde{z} - (K_a + K_b K_c) y \\ &= -1.4142 \tilde{z} - 8.071 y \end{aligned}$$

Taking the Laplace transform of this last equation, we obtain

$$U(s) = -1.4142 \tilde{z}(s) - 8.071 Y(s) \quad (2)$$

Eliminating  $\tilde{z}(s)$  from Equations (1) and (2), we have

$$U(s) = -1.4142 \frac{1}{s+5} [-25 Y(s) + U(s)] - 8.071 Y(s)$$

Simplifying,

$$(s+5) U(s) = -1.4142 [-25 Y(s) + U(s)] - (s+5) 8.071 Y(s)$$

from which we get

$$\frac{U(s)}{-Y(s)} = \frac{8.071s + 5}{s + 6.4142} = 8.071 \frac{s + 0.6195}{s + 6.4142}$$

which gives the transfer function of the observer controller. The same observer controller equation can be obtained by use of MATLAB. See the MATLAB program given below.

```

% ***** Design of Observer Controller *****

A = [0 1; 0 0]; B = [0; 1];
Aaa = 0; Aab = 1; Aaa = 0; Abb = 0; Ba = 0; Bb = 1;
Ka = [1]; Kb = [1.4142]; Ke = 5;
Ahat = Abb - Ke*Aab;
Bhat = Ahat*Ke + Aaa - Ke*Aaa;
Fhat = Bb - Ke*Ba;
Atilde = Ahat - Fhat*Kb;
Btilde = Bhat - Fhat*(Ka + Kb*Ke);
Ctilde = -Kb;
Dtilde = -(Ka + Kb*Ke);
[num,den] = ss2tf(Atilde, Btilde, -Ctilde, -Dtilde)

num =
    8.0710    5.0000

den =
    1.0000    6.4142

```

A block diagram for the designed system is shown below.

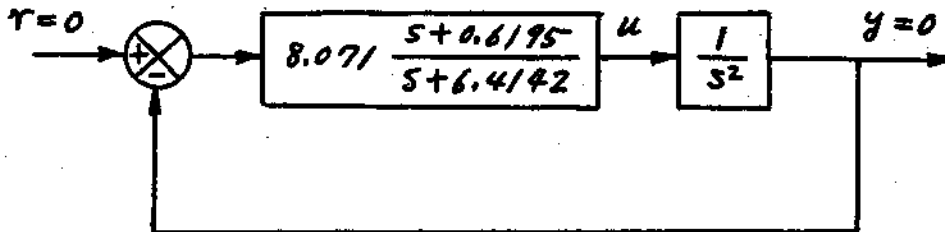

Notice that the observer controller is a lead network.

---

**B-12-14.** We shall use the MATLAB approach to solve this problem. The first MATLAB program given in the next page determines the state feedback gain matrix  $K$  and the observer gain matrix  $K_e$ . The observer to be designed is a full-order observer.

```

% ***** Determination of K and Ke *****

A=[0 1 0;0 0 1;-6 -11 -6];
B=[0;0;1];
C=[1 0 0];
J=[-1+j -1-j -5];
K=acker(A,B,J)

K=

    4    1    1

L=[-6 -6 -6];
Ke=acker(A',C',L)

Ke=

    12
    25
   -72

```

The state feedback gain matrix  $K$  and the observer gain matrix  $K_e$  thus obtained are as follows:

$$K = \begin{bmatrix} 4 & 1 & 1 \end{bmatrix}$$

$$K_e = \begin{bmatrix} 12 \\ 25 \\ -72 \end{bmatrix}$$

The second MATLAB program given below determines the transfer function of the observer controller.

```

% Obtaining transfer function of observer controller -- full-order observer

A=[0 1 0;0 0 1;-6 -11 -6];
B=[0;0;1];
C=[1 0 0];
K=[4 1 1];
Ke=[12;25;-72];
AA=A-Ke*C-B*K;
BB=Ke;
CC=K;
DD=0;
[num,den]=ss2tf(AA,BB,CC,DD)

num =

    0  1.0000  119.0000  618.0000

den =

    1.0000  19.0000  121.0000  257.0000

```

The transfer function of the observer controller is

$$\frac{U(s)}{-Y(s)} = \frac{s^2 + 119s + 618}{s^3 + 19s^2 + 121s + 257}$$

The transfer function of the given system in state space form is

$$G(s) = \frac{1}{s^3 + 6s^2 + 11s + 6}$$

A block diagram of the designed system is shown below.

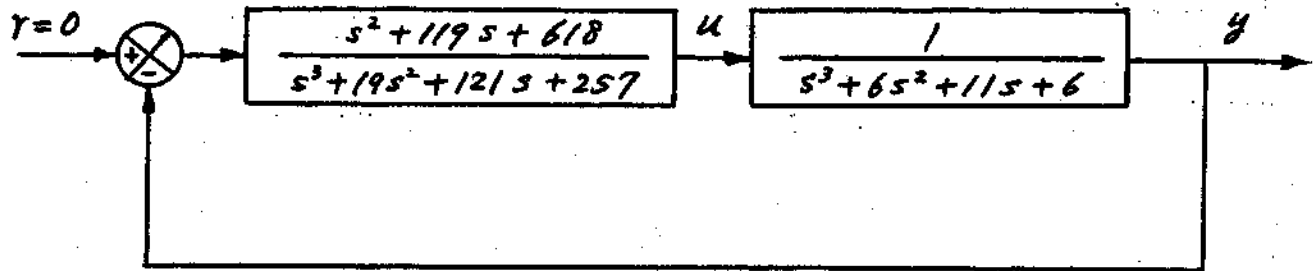

Notice that the designed system is of sixth order.

**B-12-15.** The transfer function of the plant is

$$\frac{Y(s)}{U(s)} = \frac{s^2 + 2s + 50}{s^3 + 10s^2 + 24s}$$

The corresponding differential equation is

$$\ddot{y} + 10\dot{y} + 24y = \ddot{u} + 2\dot{u} + 50u$$

Comparing this plant differential equation with the standard third-order differential equation

$$\ddot{y} + a_1\dot{y} + a_2y = b_0\ddot{u} + b_1\dot{u} + b_2u + b_3u$$

we find

$$a_1 = 10, a_2 = 24, a_3 = 0, b_0 = 0, b_1 = 1, b_2 = 2, b_3 = 50$$

Define the state variables as follows:

$$x_1 = y - \beta_0 u$$

$$x_2 = \dot{x}_1 - \beta_1 u$$

$$x_3 = \dot{x}_2 - \beta_2 u$$

where

$$\beta_0 = b_0 = 0$$

$$\beta_1 = b_1 - a_1\beta_0 = 1$$

$$\beta_2 = b_2 - a_1 \beta_1 - a_2 \beta_0 = 2 - 10 \times 1 - 0 = -8$$

$$\beta_3 = b_3 - a_1 \beta_2 - a_2 \beta_1 - a_3 \beta_0 = 50 + 10 \times 8 - 24 \times 1 - 0 = 106$$

Referring to Equation (3-36), we have

$$\dot{x}_1 = x_2 + u$$

$$\dot{x}_2 = x_3 - 8u$$

$$\dot{x}_3 = -a_3 x_1 - a_2 x_2 - a_1 x_3 + \beta_3 u = -24x_2 - 10x_3 + 106u$$

The output equation is

$$y = x_1$$

Hence the state-space representation of the plant is

$$\begin{bmatrix} \dot{x}_1 \\ \dot{x}_2 \\ \dot{x}_3 \end{bmatrix} = \begin{bmatrix} 0 & 1 & 0 \\ 0 & 0 & 1 \\ 0 & -24 & -10 \end{bmatrix} \begin{bmatrix} x_1 \\ x_2 \\ x_3 \end{bmatrix} + \begin{bmatrix} 1 \\ -8 \\ 106 \end{bmatrix} u$$

$$y = \begin{bmatrix} 1 & 0 & 0 \end{bmatrix} \begin{bmatrix} x_1 \\ x_2 \\ x_3 \end{bmatrix}$$

System with a full-order observer: We now obtain the state feedback gain matrix  $K$  and observer gain matrix  $K_e$  when the observer is a full-order one. The MATLAB program shown below produces  $K$  and  $K_e$ .

```
% ***** Determination of K and Ke for the full-order observer *****
A=[0 1 0;0 0 1;0 -24 -10];
B=[1;-8;106];
C=[1 0 0];
J=[-1+j*2 -1-j*2 -5];
format long
K=acker(A,B,J)

K=

0.5000000000000000 -0.09040074557316 -0.03984156570363

L=[-10 -10 -10];
Ke=acker(A',C',L)

Ke=

20
76
-240
```

The transfer function of the observer controller can be obtained easily with MATLAB. The MATLAB program given below produces the transfer function of the observer controller when the observer is of full order.

```

% Obtaining transfer function of observer controller — full-order observer
A=[0 1 0;0 0 1;0 -24 -10];
B=[1;-8;106];
C=[1 0 0];
K=[0.5000 -0.09040075 -0.039841566];
Ke=[20;76;-240];
AA=A-Ke*C*B*K;
BB=Ke;
CC=C;
DD=0;
format short
[num,den]=ss2tf(AA,BB,CC,DD)

num =

    0 12.6915 163.6626 500.0000

den =

 1.0000 27.0000 218.3085 554.8695

```

The transfer function of the observer controller obtained is

$$\frac{U(s)}{-Y(s)} = \frac{12.6915 s^2 + 163.6626 s + 500.0000}{s^3 + 27.0000 s^2 + 218.3085 s + 554.8695}$$

System with a minimum-order observer: We next consider the case where the state observer is a minimum-order observer. (The state feedback gain matrix  $K$  is the same as the case of the full-order observer.) The following MATLAB program produces the observer gain matrix  $K_e$  when the observer is the minimum-order observer.

```

% ***** Determination of Ke for the minimum-order observer *****
Abb=[0 1;-24 -10];
Aab=[1 0];
L=[-10 -10];
Ke=acker(Abb',Aab',L)

Ke =

    10
   -24

```

The MATLAB program shown below produces the transfer function of the observer controller based on the minimum-order observer.

```

% Obtaining transfer function of observer controller --- minimum-order observer
A = [0 1 0; 0 0 1; 0 -24 -10];
B = [1; -8; 106];
Aaa = 0; Aab = [1 0]; Aba = [0; 0]; Abb = [0 1; -24 -10]; Ba = 1; Bb = [-8; 106];
Ka = 0.5000; Kb = [-0.09040075 -0.039841566]; Ke = [10; -24];
Ahat = Abb - Ke*Aab;
Bhat = Ahat*Ke + Aba - Ke*Aaa;
Fhat = Bb - Ke*Ba;
Atilde = Ahat - Fhat*Kb;
Btilde = Bhat - Fhat*(Ka + Kb*Ke);
Ctilde = -Kb;
Dtilde = -(Ka + Kb*Ke);
[num,den] = ss2tf(Atilde, Btilde, -Ctilde, -Dtilde)

num =

    0.5522    12.6915    50.0000

den =

    1.0000    16.4478    52.7260

```

The transfer function of the observer controller obtained is

$$\frac{U(s)}{-Y(s)} = \frac{0.5522s^2 + 12.6915s + 50.0000}{s^2 + 16.4478s + 52.7260}$$

Unit-step response: The closed-loop transfer function when the observer is of full order is

$$\frac{Y(s)}{R(s)} = \frac{12.6915s^4 + 189.0456s^3 + 1461.9002s^2 + 9183.13s + 25000}{s^6 + 37s^5 + 525s^4 + 3575s^3 + 12250s^2 + 22500s + 25000}$$

The closed-loop transfer function when the observer is the minimum-order observer is given by

$$\frac{Y(s)}{R(s)} = \frac{0.6s^4 + 13.8s^3 + 103s^2 + 7345s + 2500}{s^5 + 27s^4 + 255s^3 + 1025s^2 + 2000s + 2500}$$

The unit-step response curves for both cases are shown in the next page. Notice that the unit-step response curves for both systems are almost identical.

Comparison of bandwidths of both systems: Bode diagrams of both systems are shown in the next page. The bandwidths are almost the same for both systems. The bandwidth for the system with the full-order observer is 2.4771 rad/sec. The bandwidth for the system with the minimum-order observer is 2.4201 rad/sec.

Step Response

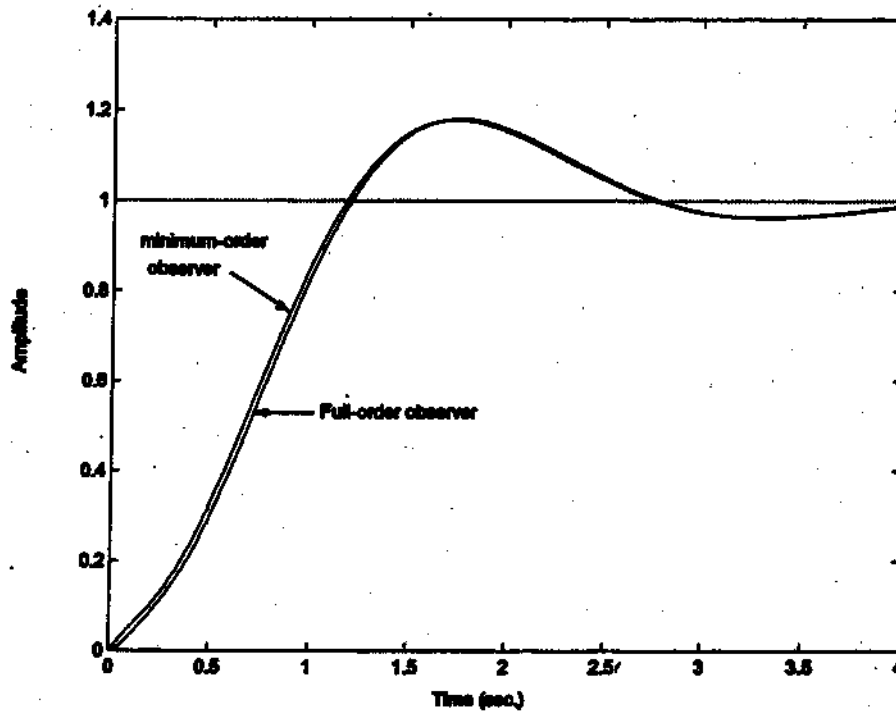

Bode Diagrams

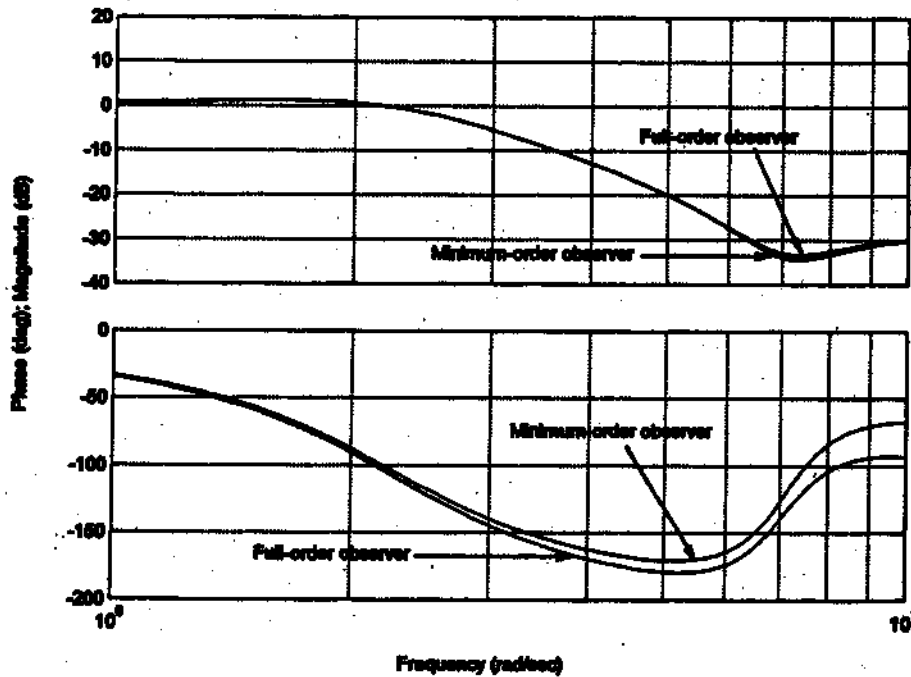

The MATLAB program to obtain the bandwidths of both systems is shown on the next page.

```

% ***** Comparison of bandwidths *****

num1 = [12.6915 189.0456 1461.9002 9183.13 25000];
den1 = [1 37 525 3575 12250 22500 25000];
num2 = [0.6 13.8 103 734 2500];
den2 = [1 27 255 1025 2000 2500];
[mag,phase,w] = bode(num1,den1,w);
n = 1;
while 20*log(mag(n)) >= -3;
n = n+1;
end
bandwidth = w(n)

bandwidth =

    2.4771

[mag,phase,w] = bode(num2,den2,w);
n = 1;
while 20*log(mag(n)) >= -3;
n = n+1;
end
bandwidth = w(n)

bandwidth =

    2.4201

```

**B-12-16.** The transfer function of the plant is

$$\frac{Y(s)}{U(s)} = \frac{1}{s(s+1)}$$

The corresponding differential equation is

$$\ddot{y} + \dot{y} = u$$

Define the state variables by

$$\begin{aligned} x_1 &= y \\ x_2 &= \dot{y} \end{aligned}$$

Then the state space representation of the plant becomes as follows:

$$\begin{bmatrix} \dot{x}_1 \\ \dot{x}_2 \end{bmatrix} = \begin{bmatrix} 0 & 1 \\ 0 & -1 \end{bmatrix} \begin{bmatrix} x_1 \\ x_2 \end{bmatrix} + \begin{bmatrix} 0 \\ 1 \end{bmatrix} u$$

$$y = \begin{bmatrix} 1 & 0 \end{bmatrix} \begin{bmatrix} x_1 \\ x_2 \end{bmatrix}$$

Now we obtain the transfer function of the observer controller with MATLAB. The MATLAB program given on the next page produces the desired observer controller.

```

% ***** Obtaining the transfer function of observer controller *****

A=[0 1;0 -1];
B=[0;1];
C=[1 0];
J=[-2+j*2 -2-j*2];
L=[-8 -8];
K=acker(A,B,J)

K=

    8    3

Ke=acker(A',C,L)

Ke=

    15
    49

AA=A-Ke*C*B*K;
BB=Ke;
CC=K;
DD=0;
[num,den]=ss2tf(AA,BB,CC,DD)

num=

    0 267.0000 512.0000

den=

    1 19 117

```

The observer controller obtained with MATLAB is

$$G_c(s) = \frac{267s + 512}{s^2 + 19s + 117}$$

Block diagrams for Systems (a) and (b) can now be redrawn as shown in the next page. In System (b), we determined N so that the steady-state output to the unit-step input is unity.

The closed-loop transfer function  $Y(s)/R(s)$  for System (a) is

$$\frac{Y(s)}{R(s)} = \frac{267s + 512}{s^3 + 20s^2 + 136s + 384s + 512}$$

The closed-loop transfer function  $Y(s)/R(s)$  for System (b) is

$$\frac{Y(s)}{R(s)} = \frac{4.3761s^2 + 83.1459s + 512}{s^3 + 20s^2 + 136s + 384s + 512}$$

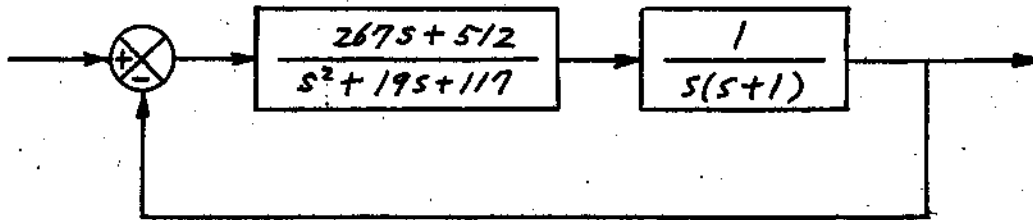

(a)

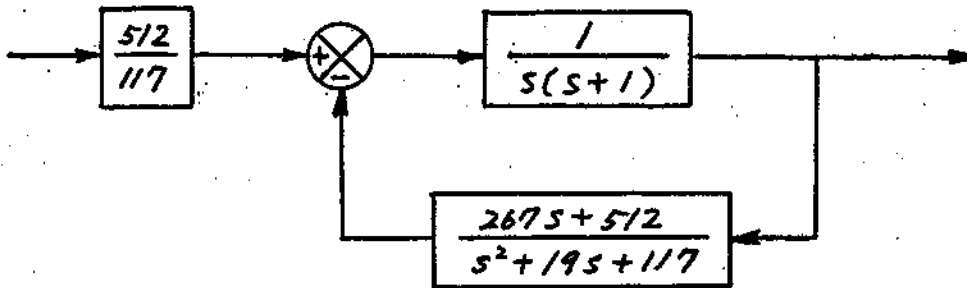

(b)

The unit-step response curves of both systems are shown below. The MATLAB program that produced these unit-step response curves is given on the next page.

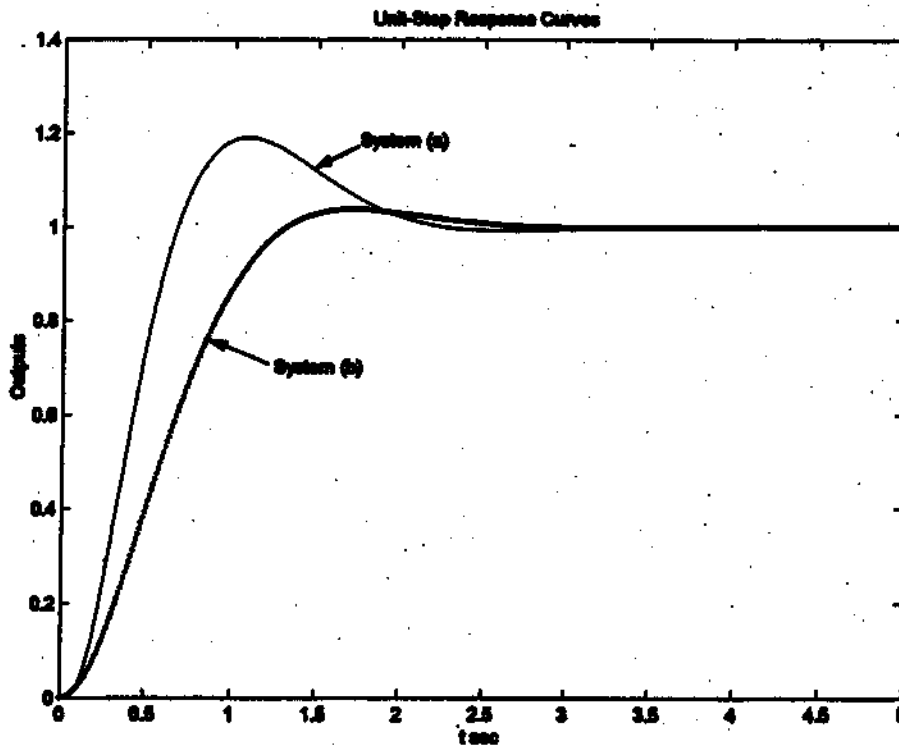

```

% ***** Unit-step response curves *****

num1 = [267 512];
den1 = [1 20 136 384 512];
num2 = [4.3761 83.1459 512];
den2 = [1 20 136 384 512];
t = 0:0.01:5;
y1 = step(num1,den1,t);
y2 = step(num2,den2,t);
plot(t,y1,'-',t,y2,'-');
title('Unit-Step Response Curves')
xlabel('t sec')
ylabel('Outputs')
gtext('System (a)')
gtext('System (b)')

```

**B-12-17.** To determine the parameter  $a$  in matrix  $A$ , we first determine matrix  $P$  from

$$A^T P + P A = -I$$

or

$$\begin{bmatrix} 0 & 0 & -1 \\ 1 & 0 & -2 \\ 0 & 1 & -a \end{bmatrix} \begin{bmatrix} P_{11} & P_{12} & P_{13} \\ P_{12} & P_{22} & P_{23} \\ P_{13} & P_{23} & P_{33} \end{bmatrix} + \begin{bmatrix} P_{11} & P_{12} & P_{13} \\ P_{12} & P_{22} & P_{23} \\ P_{13} & P_{23} & P_{33} \end{bmatrix} \begin{bmatrix} 0 & 1 & 0 \\ 0 & 0 & 1 \\ -1 & -2 & -a \end{bmatrix} = - \begin{bmatrix} 1 & 0 & 0 \\ 0 & 1 & 0 \\ 0 & 0 & 1 \end{bmatrix}$$

The result is

$$P = \begin{bmatrix} \frac{a^2 + 5a - 1}{2(2a - 1)} & \frac{2a^2 + 3}{2(2a - 1)} & \frac{1}{2} \\ \frac{2a^2 + 3}{2(2a - 1)} & \frac{a^3 + a^2 + a + 7}{2(2a - 1)} & \frac{a^2 + a + 1}{2(2a - 1)} \\ \frac{1}{2} & \frac{a^2 + a + 1}{2(2a - 1)} & \frac{a + 3}{2(2a - 1)} \end{bmatrix}$$

Then we can obtain the optimal value of the parameter  $a$  that minimizes the performance index  $J$  for any given initial condition  $x(0)$ . Since  $x(0)$  is given by

$$x(0) = \begin{bmatrix} c_1 \\ 0 \\ 0 \end{bmatrix}$$

the performance index  $J$  can be simplified to

$$J = x^T(0) P x(0) = P_{11} c_1^2$$

Therefore, we obtain

$$J = \frac{a^2 + 5a - 1}{4a - 2} c_1^2$$

To minimize  $J$ , we determine  $a$  from  $dJ/da = 0$ , or

$$\frac{4a^2 - 4a - 6}{(4a - 2)^2} = 0$$

from which we get

$$a = 1.823, \quad a = -0.823$$

Since  $a$  is specified to be positive, we discard the negative value of  $a$ . Thus, we choose  $a = 1.823$ . Noting that  $a = 1.823$  satisfies the condition for the minimum ( $d^2J/da^2 > 0$ ), the optimal value of  $a$  is 1.823.

---

B-12-18.

$$\frac{C(s)}{R(s)} = \frac{2.5K}{s^2 + 1.5s + 0.5 + 2.5K}$$

From this closed-loop transfer function, we obtain

$$25\omega_n = 1.5, \quad \omega_n^2 = 0.5 + 2.5K$$

Since  $\zeta$  is given as 0.5, we obtain

$$\omega_n = 1.5 = \sqrt{0.5 + 2.5K}$$

from which we get  $K = 0.7$ ,  $\omega_n = 1.5$ . Then we obtain

$$\frac{C(s)}{R(s)} = \frac{1.75}{s^2 + 1.5s + 2.25}$$

$E(s)/R(s)$  can then be obtained as

$$\frac{E(s)}{R(s)} = \frac{R(s) - C(s)}{R(s)} = \frac{s^2 + 1.5s + 0.5}{s^2 + 1.5s + 2.25}$$

Thus

$$\ddot{e} + 1.5\dot{e} + 2.25e = \ddot{r} + 1.5\dot{r} + 0.5r$$

Since  $r = 0$  in this problem, we have

$$\ddot{e} + 1.5\dot{e} + 2.25e = 0$$

Define  $e_1 = e$ ,  $e_2 = \dot{e}$ . Then we have

$$\begin{bmatrix} \dot{e}_1 \\ \dot{e}_2 \end{bmatrix} = \begin{bmatrix} 0 & 1 \\ -2.25 & -1.5 \end{bmatrix} \begin{bmatrix} e_1 \\ e_2 \end{bmatrix}$$

Note that

$$\int_0^{\infty} e^2(t) dt = \int_0^{\infty} e_m^T(t) Q e_m(t) dt$$

where

$$e_m(t) = \begin{bmatrix} e_1(t) \\ e_2(t) \end{bmatrix}, \quad Q = \begin{bmatrix} 1 & 0 \\ 0 & 0 \end{bmatrix}$$

Let us solve  $A_m^T P + P A_m = -Q$  for  $P$ . Using this  $P$  we obtain

$$J = \int_0^{\infty} e^2(t) dt = e_m^T(0) P e_m(0)$$

Note that for a general case of

$$A_m = \begin{bmatrix} 0 & 1 \\ -\omega_n^2 & -2\zeta\omega_n \end{bmatrix}$$

we have

$$P = \begin{bmatrix} \frac{1}{2\zeta\omega_n} + \frac{\zeta}{\omega_n} & \frac{1}{2\omega_n^2} \\ \frac{1}{2\omega_n^2} & \frac{1}{4\zeta\omega_n^3} \end{bmatrix}$$

Thus, we obtain

$$\begin{aligned} \int_0^{\infty} e^2(t) dt &= [e_1(0) \quad e_2(0)] P \begin{bmatrix} e_1(0) \\ e_2(0) \end{bmatrix} = [1 \quad 0] P \begin{bmatrix} 1 \\ 0 \end{bmatrix} \\ &= P_{11} = \frac{1}{2\zeta\omega_n} + \frac{\zeta}{\omega_n} \end{aligned}$$

By substituting  $\zeta = 0.5$  and  $\omega_n = 1.5$  into this last equation, we obtain

$$\int_0^{\infty} e^2(t) dt = \frac{2}{3}$$

**B-12-19.** The optimal control signal  $u$  will have the form  $u = -Kx$ . Therefore, the performance index  $J$  becomes

$$J = \int_0^{\infty} (x_m^T x_m + u^2) dt = \int_0^{\infty} x_m^T (I_m + K_m^T K_m) x_m dt$$

Since  $R = I$  in this problem, Equation(12-115) becomes

$$(A - BK)^T P + P(A - BK) = -(I + K^T K)$$

and Equation (12-117) becomes

$$K = R^{-1} B^T P = B^T P$$

where  $P$  is determined from the reduced matrix Riccati equation:

$$A^T P + PA - P B B^T P + I = 0$$

Solving for  $P$ , requiring that it be positive definite, we obtain

$$P = \begin{bmatrix} 2 & 1 \\ 1 & 1 \end{bmatrix}$$

The optimal feedback gain matrix  $K$  becomes

$$K = B^T P = [0 \quad 1] \begin{bmatrix} 2 & 1 \\ 1 & 1 \end{bmatrix} = [1 \quad 1]$$

Thus, the optimal control signal  $u$  is given by

$$u = -Kx = -x_1 - x_2$$

**B-12-20.** We first solve the reduced matrix Riccati equation:

$$A^* P + PA - P B R^{-1} B^* P + Q = 0$$

Noting that matrix  $A$  is real and matrix  $Q$  is real symmetric, matrix  $P$  is a real symmetric matrix. Hence the reduced matrix Riccati equation can be written as

$$\begin{bmatrix} 0 & 0 \\ 1 & 0 \end{bmatrix} \begin{bmatrix} p_{11} & p_{12} \\ p_{12} & p_{22} \end{bmatrix} + \begin{bmatrix} p_{11} & p_{12} \\ p_{12} & p_{22} \end{bmatrix} \begin{bmatrix} 0 & 1 \\ 0 & 0 \end{bmatrix} - \begin{bmatrix} p_{11} & p_{12} \\ p_{12} & p_{22} \end{bmatrix} \begin{bmatrix} 0 \\ 1 \end{bmatrix} \begin{bmatrix} 1 & 0 \end{bmatrix} \begin{bmatrix} p_{11} & p_{12} \\ p_{12} & p_{22} \end{bmatrix} + \begin{bmatrix} 1 & 0 \\ 0 & \mu \end{bmatrix} = \begin{bmatrix} 0 & 0 \\ 0 & 0 \end{bmatrix}$$

This last equation can be simplified to

$$\begin{bmatrix} 0 & 0 \\ p_{11} & p_{12} \end{bmatrix} + \begin{bmatrix} 0 & p_{11} \\ 0 & p_{12} \end{bmatrix} - \begin{bmatrix} p_{12}^2 & p_{12} p_{22} \\ p_{12} p_{22} & p_{22}^2 \end{bmatrix} + \begin{bmatrix} 1 & 0 \\ 0 & \mu \end{bmatrix} = \begin{bmatrix} 0 & 0 \\ 0 & 0 \end{bmatrix}$$

from which we obtain the following three equations:

$$1 - p_{12}^2 = 0$$

$$p_{11} - p_{12} p_{22} = 0$$

$$\mu + 2p_{12} - p_{22}^2 = 0$$

Solving these three simultaneous equations for  $p_{11}$ ,  $p_{12}$ , and  $p_{22}$ , requiring  $P$  to be positive definite, we get

$$P = \begin{bmatrix} p_{11} & p_{12} \\ p_{12} & p_{22} \end{bmatrix} = \begin{bmatrix} \sqrt{\mu+2} & 1 \\ 1 & \sqrt{\mu+2} \end{bmatrix}$$

The optimal feedback gain matrix  $K$  is obtained as

$$K = R^{-1} B^* P = [1] [0 \ 1] \begin{bmatrix} p_{11} & p_{12} \\ p_{12} & p_{22} \end{bmatrix} \\ = [p_{12} \ p_{22}] = [1 \ \sqrt{\mu+2}]$$

Thus, the optimal control signal is

$$u = -Kx = -x_1 - \sqrt{\mu+2} x_2$$

**B-12-21.** A MATLAB program to solve the given quadratic optimal control problem is shown below.

```

% ***** Quadratic optimal control *****
A = [0 1 0 0; 20.601 0 0 0; 0 0 0 1; -0.4905 0 0 0];
B = [0; -1; 0; 0.5];
Q = [100 0 0 0; 0 1 0 0; 0 0 1 0; 0 0 0 1];
R = 1;
K = lqr(A,B,Q,R)

K =

-54.0554 -11.8079 -1.0000 -2.7965

```

The state-feedback gain matrix is obtained as follows:

$$K = [-54.0554 \quad -11.8079 \quad -1.0000 \quad -2.7965]$$

Next, we shall obtain the response to the given initial condition. We substitute

$$u = -Kx$$

into the original state-space equation and obtain the following equation:

$$\dot{x} = Ax + Bu = Ax - BKx = (A - BK)x$$

The MATLAB program given below produces the response to the given initial condition. Note that  $A - B \cdot K$  is written as AA and the initial condition  $[0.1; 0; 0; 0]$  is represented by BB. The resulting response curves are shown below and on the next page.

```

% ***** Response to initial condition *****

AA = A - B*K;
BB = [0.1; 0; 0; 0];
[x,z,t] = step(AA,BB,AA,BB);
x1 = [1 0 0 0]*x';
x2 = [0 1 0 0]*x';
x3 = [0 0 1 0]*x';
x4 = [0 0 0 1]*x';

plot(t,x1)
grid
title('Response of x1, Theta')
xlabel('t Sec')
ylabel('x1 = Theta')

plot(t,x2)
grid
title('Response of x2, Theta dot')
xlabel('t Sec')
ylabel('x2 = Theta dot')

plot(t,x3)
grid
title('Response of x3, Displacement of Cart')
xlabel('t Sec')
ylabel('x3 = Displacement of Cart')

plot(t,x4)
grid
title('Response of x4, Velocity of Cart')
xlabel('t Sec')
ylabel('x4 = Velocity of Cart')

```

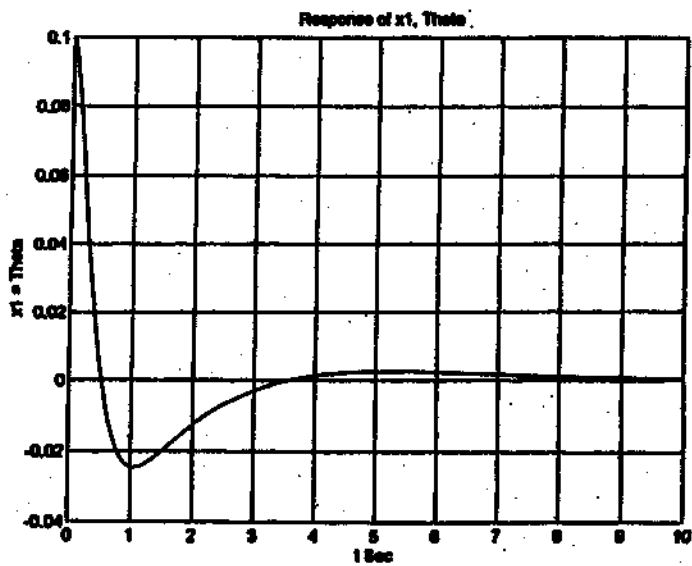

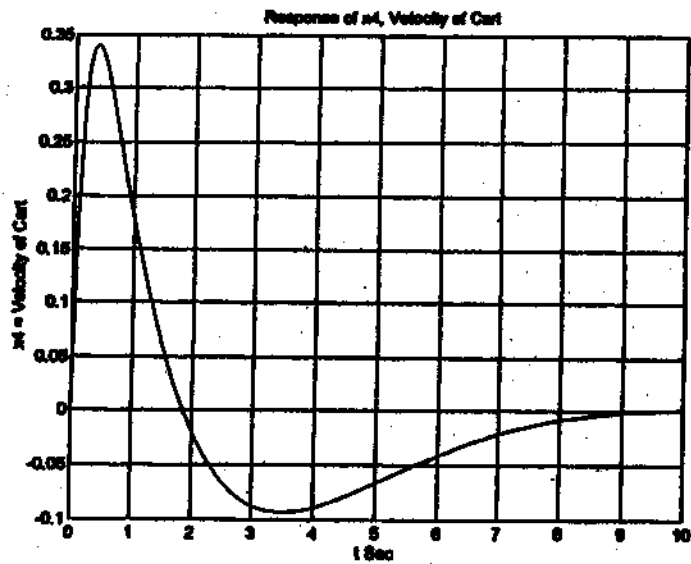
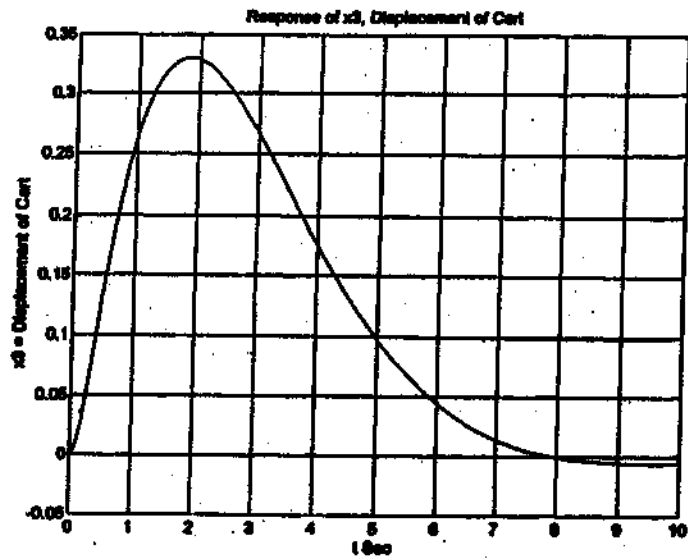
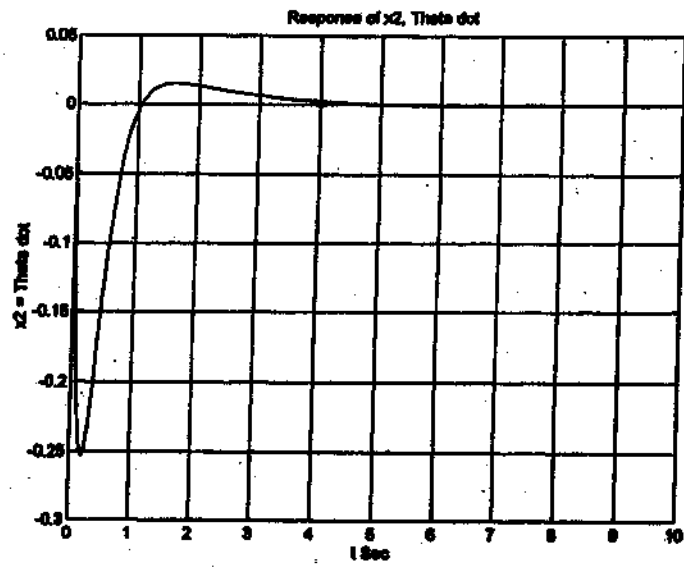



Upper Saddle River, NJ 07458

<http://www.prenhall.com>

ISBN 0-13-060908-0



9 9999 1

9 780130 609083